

DESIGN OBJECTIVES

The product described in this document has not been fully tested to ensure conformance to the requirements outlined below. Therefore AMP Ltd makes no representation or warranty, express or implied, that the product will comply with these requirements. Further, AMP Ltd may change these requirements based on the results of additional testing and evaluation. Contact AMP Engineering for further details. In case when "product specification" is referred to in this document. It should be read as "design objectives" for all times as applicable.

FG Terminal

1. Scope

1.1 Content

This specification covers the requirements for product performance, test methods and quality assurance provisions of FG Terminal.

2. Applicable Documents

The following documents form a part of this specification to the extent specified herein.

In the event of conflict between the requirements of this specification and the product drawing, the product drawing shall take precedence. In the event of conflict between the requirements of this specification and the referenced documents, this specification shall take precedence.

2.1 AMP Specifications :

- A. 109-5000: Test Specification, General Requirements for Test Methods
- B. 114-61016 : Application Specifications

3. Requirements

3.1 Design and Construction

Product shall be of the design, construction and physical dimensions specified on the applicable product drawing.

3.2 Material

- A. Receptacle Contact :
Pre Tin High Electronic Conductivity Copper Alloy
(Tin Plating 0.8 μm min)

3.3 Ratings :

- A. Voltage Rating : 300 V AC (3.96mm Pitch W-W, 6.5mm Pitch, 7.92mm Pitch 13mm Pitch W-B)
- B. Current Rating : See Fig. 1
- C. Temperature Rating : -30 °C to 105 °C (Include temperature rising by energized current)

D. Minimum Rating : 1mV, 1 μ A Minimum

Unit : A

Contact	Rec. Contact : 1743729-X Tab Contact : X-177917-X			Rec. Contact : 1743728-X Tab Contact : X-177916-X		
Wire Size Pos	AWG #16	AWG #18	AWG #20	AWG #22	AWG #24	AWG #26
1 , 2	10	8	7	5	4	3
3	9	7	6	4	3	2
4	9	7	6	4	3	2
6	8	6	5	3	2	2
8	8	6	5	3	2	2
9	8	6	5	3	2	2
10	7	5	4	2	2	2
12	7	5	4	2	2	2

Fig.1

3.4 Performance Requirement and Test Descriptions:

The product shall be designed to meet the electrical, mechanical and environmental performance requirements specified in Fig.2. All tests shall be performed in the room temperature, unless otherwise specified.

3.5 Test Requirements and Procedures Summary

Para.	Test Items	Requirements	Procedures
3.5.1	Examination of Product	Meets requirements of product drawing and AMP Specification 114-61016 After test ,no corrosion influence performance.	Visual inspection No Physical damage
Electrical Requirements			
3.5.2	Termination Resistance (Low Level)	10 m Ω Max. (Initial) 20 m Ω Max. (Final)	Subject mated contacts assembled in housing to 20mV Max open circuit at 10mA. Take the resistance of the wire only away from measurement. Fig. 6 AMP Spec. 109-5311-1
3.5.3	Insulation Resistance	1000 M Ω Min. (Initial) 500 M Ω Min. (Final)	Impressed voltage 500 V DC. Test between adjacent circuits and between the surface of housing and contact of mated connectors. AMP Spec. 109-5302
3.5.4	Dielectric withstanding Voltage	No creeping discharge nor flashover shall occur. Current leakage : 5mA Max.	2.2 kVAC for 1 minute. Test between adjacent circuits and between the surface of housing and contact of mated connectors.

3.5.5	Temperature Rising	30°C Max. under loaded specified current.		Measure temperature rising by energized current. Subject measurement must do at the place of no influence from convection of air. And contacts assembled in housing all of circuits The thermocouple attach to the contact of center circuits number Fig. 1,6 AMP Spec. 109-5310
Mechanical Requirements				
3.5.6	Vibration (Low Frequency)	No electrical discontinuity greater than 1 μ sec. shall occur. 20 m Ω Max.(Final)		Subject mated connectors to 10-55-10Hz traversed in 1 minute at 1.52mm amplitude 2 hours each of 3 mutually perpendicular planes. 100mA applied. Fig.7 AMP Spec. 109-5201
3.5.7	Physical Shock	No electrical discontinuity greater than 1 μ sec. Shall occur. Final 20 m Ω Max.		Mated Conn. (50G) Waveform : Half sine curve Duration : 11 m sec. Number of Drops : 3 drops each to normal and reversed directions of X.Y and Z axes, totally 18 drops. AMP Spec. 109-5208 See Fig. 7
3.5.8	Connector Mating /Unmating Force	Mating Force	(13.72 X Pos.)N Max. (1.4 X Pos.)Kg Max	Operation Speed : 100mm/min Measure the force required to mate/unmate connectors. However, It is measure without HSG Lock.
		Unmating Force	(1.96 X Pos.)N MIN. (0.2 X Pos.)Kg MIN	
3.5.9	Contact Insertion Force	6.86 N (0.7 Kgf) Max. per contact.		Measure the force required to insert contact into housing AMP Spec. 109-5211
3.5.10	Contact Retention Force	41.16 N (4.2 Kgf) Min. per contact		Apply an axial pull-off load to crimped wire . Use the wire of AWG #16 or #18 . Operation Speed : 100 mm/min. AMP Spec. 109-5210.
3.5.11	Contact Mate/Unmating Force	Mate Force	13.72 N(1400g)Max (1 st ~25 th)	Measured by gauge tab (Fig.8) Operation Speed : 100 mm/min. AMP Spec. 109-5206
		Unmating Force	0.58N(60g)Min.(1 st) 0.39N(40g)Min.(25 th)	
3.5.12	Crimp Tensile Strength	Wire Size		Crimp Tensile (min)
		mm ²	(AWG)	
		0.14	26	19.6(2)
		0.22	24	29.4(3)
		0.31	22	49.0(5)
		0.51	20	58.8(6)
		0.87	18	68.6(7)
1.27	16	78.4(8)		
Apply an axial pull-off load to crimped wire of contact secured on the tester, Operation Speed : 100mm/min. Subject take insulation barrel away. AMP Spec.109-5205				

3.5.13	Durability (Repeated Mate/Unmat ing)	Mating	(13.72xPos.)N Max. (1.4xPos.)N Max.	No. of Cycles : 25 cycles
		Unmating	(1.96xPos.)N Min. (0.2xPos.)Kg Min.	
3.5.14	Housing Locking Strength	34.3 N(3.5Kgf) Min. (2~4 Pos.) 44.1 N (4.5 Kgf) Min. (6,8,9,12 Pos.)		Measure connector locking strength. Operation Speed : 100 mm/min. AMP Spec. 109-5210
3.5.15	Post Retention Force	9.8N (1.0 Kgf)Min.		Measure post retention force Operation Speed : 100mm/min.
Environmental Requirements				
3.5.16	Thermal Shock	20 mΩ Max. (Final)		Mated connector -55°C/30 min. 85°C/30min. Making this a cycle, repeat 25 cycles. AMP Spec. 109-5103 Condition A The measurement is held after being left indoor for 3 hours.
3.5.17	Humidity- Temperature Cycling	Dielectric withstanding voltage 2.2KV AC 1 minute. Insulation resistance(final) 500 MΩ Min. Termination resistance 20 mΩ Max. (Final)		Mated connector, 25~65°C, 80 ~ 98% R.H. 10 cycles Cold shock -10°C (not) performed AMP Spec. 109-5106 The measurement is held after being left indoor for 3 hours.
3.5.18	Salt Spray	20 mΩ Max. (Final) No corrosion influence performance		Subject mated connector to 5%±1% salt concentration for 48 hours. The measurement is held after remove the salt and dry up at indoor.
3.5.19	Heat Aging	20 mΩ Max. (Final)		Mated connector 150°C ± 2°C ,96 hours AMP Spec. 109-5108 condition A
3.5.20	Resistance to Cold	20 mΩ Max. (Final)		Mated connector -30°C±2°C,96 hours AMP Spec. 109-5108-3 Condition D But temperature shall be applicable to the above.
3.5.21	H ₂ S	20 mΩ Max.(Final) No corrosion influence performance		Mated connector 3 ± 1 ppm , 40 ± 2°C 96 hours
3.5.22	Solderability	Wet Solder Coverage : 90 % Min.		Solder Temperature : 230±5°C Immersion Duration : 3±0.5 seconds
3.5.23	Resistance to Soldering Heat	No physical damage shall occur.		Test connector on PCB. Solder Temperature :260±5°C Immersion Duration : 10±0.5 sec. AMP Spec. : 109-5204

Product must be without rust, corrosion transformation , crack and discoloration.

Fig. 2



3.6 Product Qualification and Test Sequence

Test Examination	Test Group																	
	1	2	3	4	5	6	7	8	9	10	11	12	13	14	15	16	17	18
	Test Sequence (a)																	
Examination of Product	1, 3	1,4	1,4	1	1,3	1,4	1,7	1,7	1,4	1,4	1,4	1,4	1,4	1,4	1,4	1,3	1,3	1,3
Termination Resistance (Low Level)							2,4,6	3,6	2,5	2,5	2,5	2,5	2,5	2,5	2,5			
Dielectric withstanding Voltage						3				7								
Insulation Resistance						2				6								
Temperature Rising					2													
Vibration (Low Frequency)							5											
Physical Shock							3											
Connector Mating Force								2										
Connector Unmating Force								4										
Contact Mating Force		2																
Contact Unmating Force		3																
Crimp Tensile Strength	2																	
Durability (Repeated Mate/Unmating)								5										
Housing Locking Strength			3															
Post Retention Force																	2	
Solderability																		2
Humidity-										3								

Temperature Cycling																	
H2S												3					
Resistance to Soldering Heat																	2
Thermal Shock								3									
Salt Spray										3							
Resistance to Cold												3					
Contact Retention Force						5											
Temperature Life (Heat Aging)											3						

Fig. 3

(a)Numbers indicate sequence in which the tests are performed

4. Quality Assurance Provisions :

4.1 Test Conditions :

Unless Otherwise specified, all the tests shall be performed in any combination of the following test conditions.

Temperature	15 ~ 35 °C
Relative Humidity	45 ~ 75 %
Atmospheric Pressure	86.6 ~ 106.6 Kpa

Fig. 4

4.2 Tests :

4.2.1 Test Specimens :

The test specimens to be employed for the tests shall be conforming to the requirements Specified in the applicable product drawing. The crimped contacts shall be prepared in accordance with the requirements of applicable application Specification, 114-61016, Crimping of FG Terminals on the wires specified in Fig. 5

4.2.2 Applicable Wires

The wires to be used for crimping the samples for performance testing shall be conforming to the requirements specified in Fig. 5

Calculated Cross Sectional Area (mm ²)	AWG	Diameter of a Conductor (mm)	Number of Conductors	Insulation Outer Diameter(mm)
0.14	26	0.16	7	1.30
0.22	24	0.16	11	1.5
0.31	22	0.18	12	2.0
0.51	20	0.18	20	2.6
0.76	18	0.18	30	2.8
1.27	16	0.18	50	3.1

Fig. 5

Wire-to-Wire Termination Type :

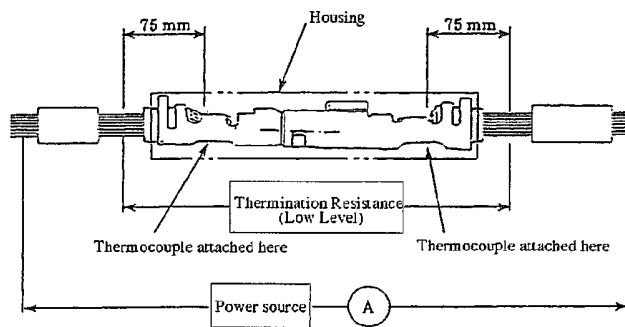

* Take the resistance of 150mm wire only away.

<Continued>

Wire-to-Board Terminal Type :

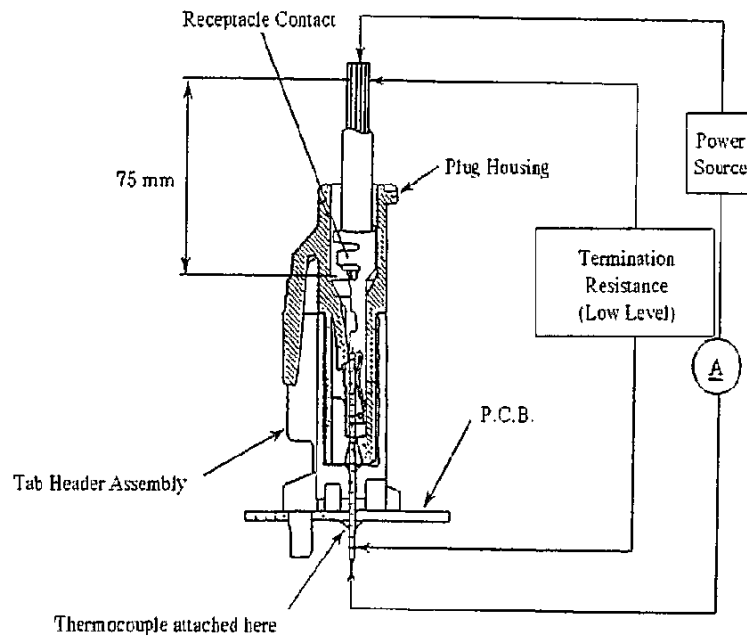

*Take the resistance of 75mm wire only away.

Termination Resistance (Low Level) and Temperature
Rising Vs. Current Measuring Methods

Fig.6

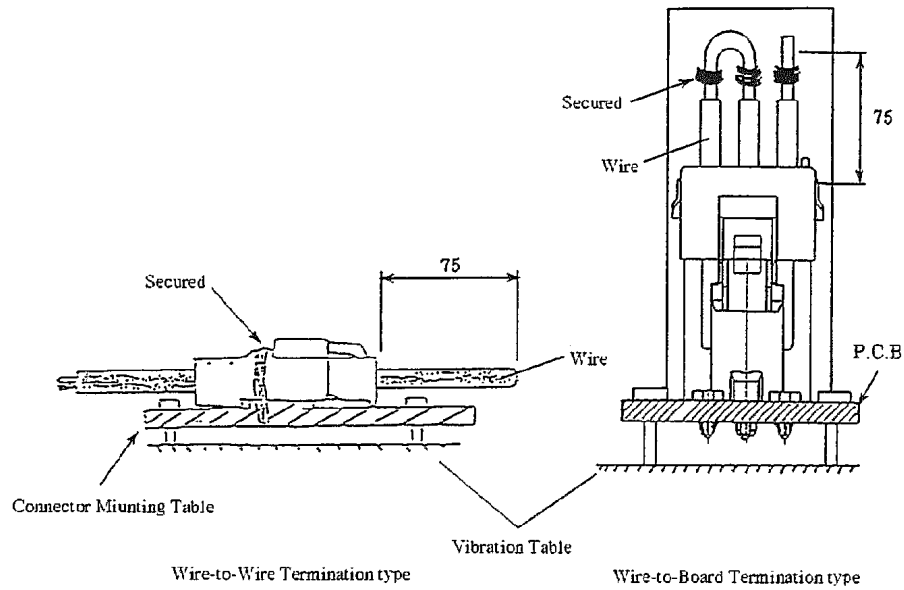

Connector Mounting Methods of Low Frequency Vibration and Physical Shock Tests
Fig.7

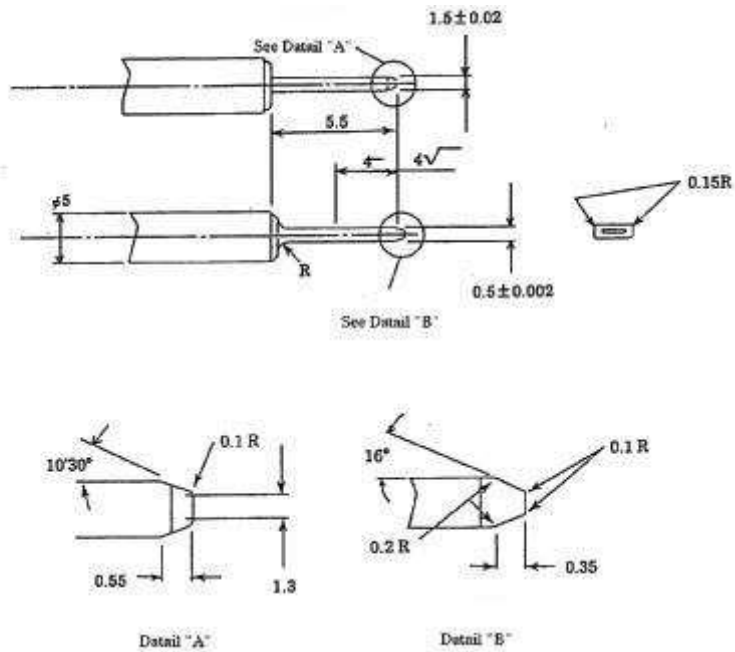

Gage Design for Contact Mating/Unmating Force Tests
Fig.8



5. REVISION HISTORY

Rev.	REVISION RECORD	DATE
A	Initial release	20AUG2014

6. SPECIFICATION APPROVAL

Prepared by,
BH Cho

Checked By,

Product Engineer

Senior Product Engineer

Approved by,
BW Kang

Product Engineering Manager