

1. Scope:

1.1 Contents

This specification covers the requirements for product performance, test methods and quality assurance provisions of 040III HIGH DENSITY CONNECTOR

72pos/86Pos/94Pos/108Pos/122Pos/125Pos for Wire-to-Board Termination.

Applicable product description and part numbers are as shown in Appendix 1.

2. Applicable Documents:

The following documents form a part of this specification to the extent specified herein. In the event of conflict between the requirements of this specification and the product drawing, the product drawing shall take precedence. In the event of conflict between the requirements of this specification and the referenced documents, this specification shall take precedence.

2.1 AMP Specifications:

- A. 109-5000 : Test Specification, General Requirements for Test Methods
- B. 114-5217 : Crimping 040 III Series Receptacle Contact
- C. 501-5487 : Qualification Test Report

2.2 Commercial Standards and Specifications.

- A. JASO D605 : Multi-pole Connector for Automobiles
- B. JASO D7101 : Test Methods for Plastic Molded Parts
- C. JIS C3406 : Low Voltage Wires and Cables for Automobiles
- D. JIS D0203 : Method of Moisture, Rain and Spray Test for Automobile Parts
- E. JIS D0204 : Method of High and Low Temperature Test for Automobile Parts
- F. JIS D1601 : Vibration Testing Method for Automobile Parts
- G. JIS R5210 : Portland Cement
- H. MIL-STD-202 : Testing Method 208 : Method of Soldering

3. Requirements :

3.1 Design and Construction:

Product shall be of the design, construction and physical dimensions specified on the applicable product drawing.

3.2 Material :

A. Contact :

a. Receptacle Contact : Pre-tinned Phosphor bronze

b. Tab Contact : Pre-tinned Copper alloy

B. Housing : PBT resin

3.3 Ratings:

A. Temperature Rating : -30°C to 105°C

3.4 Performance Requirements and Test Descriptions:

The product shall be designed to meet the electrical, mechanical and environmental performance requirements specified in Fig.2. All tests shall be performed in the room temperature, unless otherwise specified.

3.5 Test Requirements and Procedures Summary:

Para.	Test Items	Requirements	Procedures
3.5.1	Confirmation of Product	Product shall be conforming to the requirements of applicable product drawing and Application Specification.No.114-5217	Visually, dimensionally and functionally inspected per applicable quality inspection plan.
Electrical Requirements			
3.5.2	Termination Resistance (Low Level)	10m Ω Max. (Initial) 20m Ω Max. (Final)	Subject mated contacts assembled in housing to closed circuit current of 10mA Max. at open circuit voltage of 20mV Max. Fig.3 AMP Spec.109-5311-1
3.5.3	Termination Resistance (Specified Current)	10m Ω Max. (Initial) 20m Ω Max. (Final)	Measure initial mill volt drop of contact test circuit in mated connectors. Fig.3 AMP Spec.109-5311-2
3.5.5	Insulation Resistance	100M Ω Min.	Impressed voltage 500V DC. Test between adjacent circuits of mated connectors. Fig.4 AMP Spec. 109-5302
3.5.4	Dielectric Strength	No creeping discharge nor flashover shall occur.	1kVAC for 1 minute. Test between adjacent circuits of mated connectors. Fig.4 AMP Spec. 109-5301
3.5.6	Temperature Rising	Represent inter relative characters between temperature rising of energized contact crimp vs. current intensity in graph. No abnormal temperature rising shall take place.	Measure temperature rising by engaged current.(Measure until the temperature rising reaches 80°C) AMP Spec. 109-5310
3.5.7	Current Leakage	1mA Max	12V DC impressed 1min. Fig.5 AMP Spec. 109-5312
Physical Requirements			
3.5.8	Handling Ergonomics	No abnormalities allowed in Manualmating/unmating handling.	Manually operated
3.5.9	Contact Mating Force	4.9N Max	Operation Speed : 100mm/min. Measure the force required to mate contacts. AMP Spec.109-5206
3.5.10	Contact Unmating Force	0.98N Min.	Operation Speed : 100mm/min. Measure the force required to unmate contacts. AMP Spec.109-5206

Fig.1 (To be continued)

Para.	Test Items	Requirements	Procedures
3.5.11	Insertion Force of Housing Unit	29.4N Max.	Operation Speed : 100mm/min. Measure the force required to mate Housing Unit. AMP Spec.109-5206
3.5.12	Housing Locking Strength	98N Min.	Measure housing locking strength. Operation Speed:100mm/min. AMP Spec. 109-5210
3.5.13	Connector Mating Force	17Pos.147N Max. 22Pos.147N Max. 24Pos.147N Max. 31Pos.147N Max.	Operation Speed : 100mm/min. Measure the force required to mate connectors. AMP Spec.109-5206
3.5.14	Connector Unmating Force	17Pos.147N Max. 22Pos.147N Max. 24Pos.147N Max. 31Pos.147N Max.	Operation Speed:100mm/min. Measure the force required to unmate connectors. AMP Spec. 109-5206
3.5.15	Contact Insertion Force	9.8N Max. par contact.	Measure the force required to insert contacts into housing. AMP Spec. 109-5211
3.5.16	Contact Retention Force (Pre-Lock)	39.2N Min.	Apply an axial pull-off load to crimped wire. Operation Speed: 100mm/min. AMP Spec. 109-5212
3.5.17	Connector Retention Force	58.8N Min.	Operation Speed:100mm/min. Measure the force required to pull off the housing from the connector or to break the locking.
3.5.18	Reverse Insertion of Housing	Shall not be inserted the other way.	Attempt to mate in the direction other than normal mating .
3.5.19	Reverse Insertion of Terminal	Shall not be inserted the other way.	attempt to load the contact in the direction other than normal way.
3.5.20	Releasing Force of Lock	49.0N Max.	Measure releasing force of lock.

3.5.21	Crimp Tensile Strength	Wire size		Crimp tensile(Min)	Apply an axial pull-off load to crimped wire of contact secured on the tester. Operation Speed:100mm/min. AMP Spec. 109-5205
		mm ²	(AWG)	N	
		0.3	22	58	
		0.5	20	88	
		0.85	18	127	
		1.25	16	177	

Fig.1 (To be continued)

Para.	Test Items	Requirements	Procedures
3.5.22	Contact Retention Force (Secondary-Lock)	78N Min.	Apply an axial pull-off load to crimped wire. Operation Speed: 100mm/min.
3.5.23	Fitting Force of Double Lock Plate	59N Max.	Operation Speed:100mm/min. Measure the fitting force of double lock plate.
3.5.24	Solderability	Wet Solder Coverage: 95%Min.	Solder Temperature :230±5°C Immersion Duration :3±0.5seconds Flux: Alpha 100 AMP Spec. 109-5203

Environmental Requirement			
3.5.25	Temperature Life (Heat Aging)	(Low level) : 20m Ω Max. (Final) Contact Retention Force: 0.98N Min.	120°C,Duration:120hours AMP Spec. 109-5104
3.5.26	Resistance to Cold	(Low level) : 20m Ω Max. (Final)	-40±2°C, 120hours AMP Spec. 109-5108
3.5.27	Thermal Shock	(Low level) : 20m Ω Max. (Final) Satisfied 3.5.21 Crimp Tensile Strength	-30°C/120min.,80°C/120min. Making this a cycle, repeat 5cycles. AMP Spec. 109-5103
3.5.28	Humidity, Steady State	(Low level) : 20m Ω Max. (Final) Insulation resistance: 100M Ω Min. (Final) 1kVAC for 1 minute : No creeping discharge nor flashover shall occur. Contact Retention Force: 0.98N Min. Connector Retention Force : 58.8N Min. Current Leakage : 1mA Max.	Mated connector, 90~95%R.H.,60°C 96hours AMP Spec. 109-5105
3.5.29	Current Cycling	(Low level) : 20m Ω Max. (Final) No ignition is allowed during the test. Temperature rise in the terminal press point area shall be 20°CMax.	45minutes"ON",15minutes"OFF", 1000cycles. Current intensity shall cause temperature rising up to 40°C. AMP Spec.109-5308
3.5.30	Durability (Repeated Mate/Unmating)	(Specified Current) : 20m Ω Max. (Final)	Operation Speed: 100mm/min. No. of Cycles:20 Cycles. AMP Spec.109-5213

Fig.1 (To be continued)

Para.	Test Items	Requirements	Procedures
3.5.31	Resistance to "Kojiri"	(Specified Current) : 20m Ω Max. (Final)	Secure one of the connectors on the table, and with the half mated condition, apply the bending force of 98N in front-rear and right-left directions two times. Making this a cycle, repeat 10 cycles.
3.5.32	Vibration (High Frequency)	No electrical discontinuity greater than 1 μ sec. shall occur. (Specified Current) : 20m Ω Max. (Final)	Vibration Frequency: 20~400Hz/6min. Accelerated Velocity: 44.1m/s ² Vibration Direction : Up and Down, Back and Force, Right and Left Directions : Each 3hours Open circuit voltage : 13V Closed circuit current : 1 ± 0.1A
3.5.33	Resistance Oil	(Specified Current) : 20m Ω Max. (Final)	Immerse the connector in the engine-oil mixture of SAE 10W or equivalent and kerosene conforming to JIS K 2203(Kerosene)K No.2 in equal quantity kept at 50 ± °C for 20 hours.
3.5.34	Dust Bombardment	(Specified Current) : 20m Ω Max. (Final)	Subject JIS R 5210 cement blow of 1.5Kg per 10 seconds in 15 minutes intervals for 8 cycles, which Unmate/Re-mating per 2 cycles. AMP Spec. 109-5110
3.5.35	Industrial Gas (SO ₂)	(Low level) : 20m Ω Max. (Final)	SO ₂ Gas : 10ppm, 90~95%R.H. 40°C, 24hours AMP Spec. 109-5107
3.5.36	Resistance to Ammonia	Satisfied 3.5.21 Crimp Tensile Strength	The ammoniacal water solution 100ml(concentration:1%) in the sealed glass container(20~25l),which pedestal the samples leave 96hours.

Fig.1 (End)

3.6 Product Qualification Test Sequence

Para.	Test Items	Test Group															
		1	2	3	4	5	6	7	8	9	10	11	12	13	14	15	16
		Test Sequence (a)															
3.5.1	Confirmation of Product	1	1	1	1	1	1	1	1	1	1	1	1	1	1	1	1
3.5.2	Termination Resistance (Low Level)	2								2,4		2,4	2,4,7,9			6	
3.5.3	Termination Resistance (Specified Current)	3												4,6,8	2,4,6	2,4	
3.5.4	Insulation Resistance	4											10				
3.5.5	Dielectric Strength	5											11				
3.5.6	Temperature Rising	7															
3.5.7	Current Leakage	6											12				
3.5.8	Handling Ergonomics													2			
3.5.9	Contact Mating Force		2														
3.5.10	Contact Unmating Force		3										5				
3.5.11	Insertion Force of Housing Unit			2													
3.5.12	Housing Locking Strength			3													
3.5.13	Connector Mating Force				2												
3.5.14	Connector Unmating Force						3										
3.5.15	Contact Insertion Force					2											
3.5.16	Contact Retention Force(Pre-Lock)								2								
3.5.17	Connector Retention Force				3								13				
3.5.18	Reverse Insertion of Housing													3			
3.5.19	Reverse Insertion of Terminal		4														
3.5.20	Releasing Force of Lock							2									
3.5.21	Crimp Tensile Strength		5										5				3
3.5.22	Contact Retention Force(Secondary Lock)						4										

Fig.2 (To be continued)

Para.	Test Items	Test Group															
		1	2	3	4	5	6	7	8	9	10	11	12	13	14	15	16
		Test Sequence (a)															
3.5.23	Double Lock Plate Locking Strength					2											
3.5.24	Solderability									2							
3.5.25	Temperature Life (Heat Aging)										3						
3.5.26	Resistance to Cold										6						
3.5.27	Thermal Shock										3						
3.5.28	Humidity, Steady State										8						
3.5.29	Current Cycling									3							
3.5.30	Durability(Repeated Mate/Unmating)											5					
3.5.31	Resistance to "Kojiri"												3				
3.5.32	Vibration (High Frequency)												5				
3.5.33	Resistance to Oil											7					
3.5.34	Dust Bombardment													3			
3.5.35	Industrial Gas (SO ₂)													5			
3.5.36	Resistance to Ammonia															2	

(a) Numbers indicate sequence in which tests are performed.

Fig.2 (End)

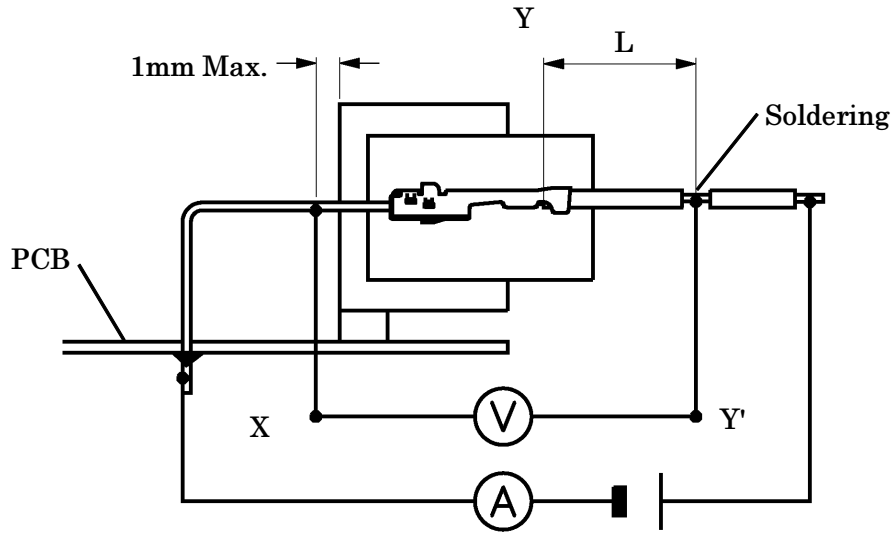

Deduct resistance of Y-Y'(wire "L") from X-Y'

Fig.3

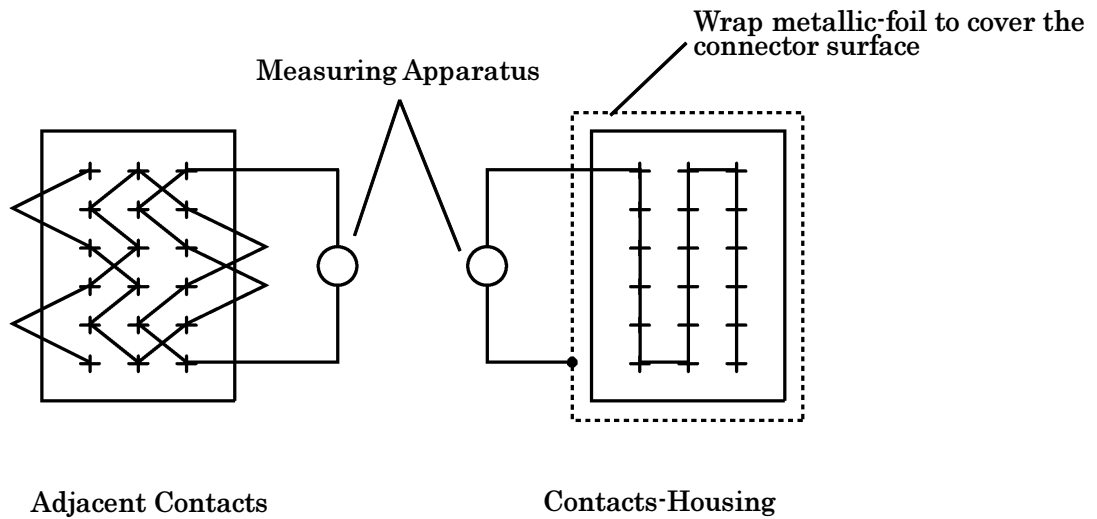

Fig.4

040III HIGH DEHSITY CONNECTOR
72POS/86POS/94POS/108POS/122POS/125POS

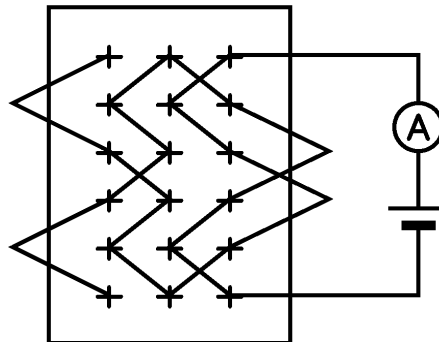

Fig.5

The applicable product descriptions and part numbers are as shown in Appendix 1.

Appendix 1

Prod.P/N	Description
353027-□	17 Position Plug-housing Assembly
353028-□	22 Position Plug-housing Assembly
353029-□	24 Position Plug-housing Assembly
353826-□	31 Position Plug-housing Assembly B Type
1318682-□	31 Position Plug-housing Assembly C Type
353015-3	122 Position Cap-housing Assembly
1318612-1	125 Position Cap-housing Assembly
1318613-1	108 Position Cap-housing Assembly
1318614-1	86 Position Cap-housing Assembly
1123038-2	72 Position Cap-housing Assembly
1123042-3	72 Position Cap-housing Assembly without several contacts
316836-1	040III "S" Receptacle Contact (Tin-plate)
1123653-1	040III "MS" Receptacle Contact (Tin-plate)
316838-1	040III "M" Receptacle Contact (Tin-plate)
1473181-1	94 Position Cap-housing Assembly B Type