

**DESIGN OBJECTIVES.**

The product described in this document has not been fully tested to ensure conformance to the requirements outlined below. Therefore, AMP (Japan) Ltd makes no representation or warranty, express or implied, that the product will comply with these requirements. Further, AMP (Japan) Ltd. may change these requirements based on the results of additional testing and evaluation. Contact AMP Engineering for further details.

In case when "product specification" is referred to in this document, it should be read as "design objectives" for all times as applicable.

1. Scope:

This specification covers requirements for product performance and test methods of stacking connector of the following part numbers.

Product Nos.	Descriptions	Type of Stacking
X-173146-X	Post Heder Assembly	For stacking a top or a bottom board
X-173145-X	Receptacle Assembly (Long Type)	For stacking intermediate boards
	Receptacle Assembly (Short Type)	For stacking a top or a bottom board
X-173144-X	Post Hood	For stacking intermediate boards

Fig. 1

- (1) The PCB applied combination with these connectors, can make number of printed circuit boards stacked in parallel with each other to connect the circuits electrically.
- (2) The product connectors can be applied to the printed circuit boards having thickness of 1.6mm.
- (3) The post headers and the receptacle assemblies (short type) are used for stacking a top or a bottom board, and the receptacle assemblies (long type) and the post hoods are used to stacking intermediate boards.

2. Applicable Documents:

The following standard and specifications form part of this specification to the extent specified herein.

- |             |  |
|-------------|--|
| JIS C 5420  | General Rules of Connectors for Printed Wiring Boards    |
| MIL-STD-202 | Test Methods for Electronic and Electric Component Parts |
| MIL-G-45204 | Gold Plating, Electrode Deposited                        |
| QQ-N-290    | Nickel Plating (Electrodeposited)                        |

AMP SECURITY CLASSIFICATION  
 Customer Release  
 NUMBER 108-5197

PRINT DIST	A2	Design Objectives	KNYT	11-25-85	DR	<i>[Signature]</i>	<b>AMP</b>	AMP (Japan), Ltd. TOKYO, JAPAN		
	A1	Revised RFA-1481	<i>[Signature]</i>	11-25-85	CHK	<i>[Signature]</i>		LOC	NO	REV
	A	Revised RFA-836	K.S	11-25-85	APP	<i>[Signature]</i>	J	A	108-5197	A2
	O	Released RFA-836	K.S	11-25-85	SHEET		Product Design Objectives			
	LTR	REVISION RECORD	DR	CHK	DATE	1 OF 10		Stacking Connector		

NUMBER 108-5197

NUMBER

Customer Release

AMP SECURITY CLASSIFICATION

3. Material and Finish:

3.1 Receptacle Contact:

- (1) Material: CA 725 (Nickel-Copper Alloy)
- (2) Finish: Overall Nickel Underplate..... 1.3 μm min.  
 Long Type Contact Area .... Gold Plating 0.2 μm min. (Mating)  
 Action Area ..... Gold Flash  
 Post Area ..... Gold Plating 0.2 μm min.  
 Short Type Contact Area .... Gold Plating 0.2 μm min. (Mating)  
 Other Areas ..... Tin-Lead Plating 1 - 2.5 μm

3.2 Post Contact

- (1) Material: CA 725 (Nickel-Copper Alloy)
- (2) Finish: Overall Nickel Underplate..... 1.3 μm min.  
 Post Contact Area, Gold Plating 0.2 μm min.  
 Action Area ....Tin-Lead Plating 1 - 2.5 μm min.

3.3 Receptacle Housing:

- (1) Material: Polybutylene-Terephthalate (PBT), Glass-filled 15%, Molded Resin
- (2) Flammability: UL94V-0

3.4 Post Header Housing:

- (1) Material: Polybutylene-Terephthalate (PBT), Glass-filled 15%, Molded Resin
- (2) Flammability: UL94V-0

3.5 Post Hood Housing:

- (1) Material: Polybutylene-Terephthalate (PBT), Glass-filled 15%, Molded Resin
- (2) Flammability: UL94V-0

4. Appearance and Color:

4.1 Appearance:

Connector shall have normal appearance without defects such as flaw, cracks, deformation, blister, dirt and burrs, that are detrimental to connector functions and merchandising cosmetic value.

4.2 Color:

The color of the housing shall be black.

SHEET				AMP (Japan), Ltd. TOKYO, JAPAN	
2 OF 10		LQC	NO	108-5197	
		J	A	REV. A2	
NAME Product Design Objectives Stacking Connector					

## 5. Product Design Feature, Construction and Dimensions:

Product design feature, construction and dimensions shall be conforming to the applicable product drawing(s).

## (1) Number of Positions:

The connectors of 26, 30, 34, 40, 50 and 60-Pos. are available in 6 types.

## (2) Centerline Spacing:

The centerline spacing is 2.54mm with 2.54mm row distance.

## (3) Applicable Printed Circuit Board:

Applicable printed circuit board shall have thickness of  $1.6 \pm 0.13$ mm, containing glass-fiber and epoxy material.

## 6. Performance:

## 6.1 Ratings:

- (1) Current Rating: 1.5A max.
- (2) Voltage Rating: 250V AC max.
- (3) Temperature Rating:  $-25^{\circ}\text{C} \sim +85^{\circ}\text{C}$

## 6.2 Electrical Performance Requirements:

Test Items	Performance Requirements	Test Methods
Termination Resistance: (Low Level) Para. 6.2.1	25m $\Omega$ max. (Initial) 30m $\Omega$ max. (Final)	Measurements shall be made according to Method 307 of MIL-STD-202, with receptacle mated with post header that has been mounted on PCB as shown in Fig. 7. Use test current of open circuit voltage of 50mV max. with closed circuit current of 50mA max.
Insulation Resistance: Para. 6.2.2	5,000M $\Omega$ min. (Initial) 1,000M $\Omega$ min. (Final)	Measurements shall be made according to Condition "A", Method 302 of MIL-STD-202 (100V $\pm 10\%$ ), between adjacent contacts in the unmated connector.
Dielectric Strength: Para. 6.2.3	No insulation breakdown nor flashover shall occur.	Test shall be made according to Method 301 of MIL-STD-202, by applying test potential between adjacent contacts. Test Voltage shall be 1,000V (r.m.s.) AC, and hold the voltage for 1 minute.

Fig. 2

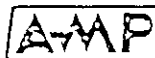
SHEET			AMP (Japan), Ltd. TOKYO, JAPAN	
3 OF 10	LOC J   A	NO 108-5197	REV. A2	
NAME Product Design Objectives Stacking Connector				

AMP SECURITY CLASSIFICATION	CUSTOMER RELEASE	NUMBER	6.3 Mechanical Performance Requirements:				
			Test Items	Performance Requirements	Test Methods		
		108-5197	Connector Insertion/ Extraction Force: Para. 6.3.1	No. of Pos.	Insertion Force kg (Max.)	Extraction kg (Min.)	A pair of post header and re-ceptacle connector shall be mated and unmated at a rate of 100mm a minute maximum after properly setting on tensile testing machine. The force required to mate and to unmate the connector, shall be measured and recorded.
	26			4.7	0.78		
	30			5.4	0.9		
	34			6.1	1.02		
	40			7.2	1.2		
	50			9.0	1.5		
	60			10.8	1.8		
			Contact Retention Force: Para. 6.3.2	Receptacle Connector: 500 g min. per Contact Post Header: 1.0kg min. per Contact	A contact loaded in a connector shall be axially pulled at a rate of 100mm a minute maximum, by using a force gage to measure the force required to dislodge the contact from connector cavity.		
			Insertion Force of Action Pin: Para. 6.3.3	10.5 kg max.	Each pin shall be axially inserted in PCB for the test specified in Fig. 2 with the use of a force gage to make measurement of insertion force.		
			Retention Force of Action Pin: Para. 6.3.4	2.0 kg min.	Each pin mounted on PCB for the test, specified in Fig. 2, shall be perpendicularly pushed from the side opposite to the insertion with the use of a force gage to make measurements of retention force.		

Fig. 3

6.4 Physical Performance Requirements

Test Items	Performance Requirements	Test Methods
Durability: Para. 6.4.1	Appearance: No abnormalities, detrimental to connector functions shall be evident. Low level termination resistance shall meet Para. 6.2.1. Insertion/extraction force shall meet Para. 6.3.1.	Repeat insertion/extraction test conditioning for 50 cycles, in the same manner as specified in Para. 6.3.1.

Fig. 4 (To be continued)

SHEET				AMP (Japan), Ltd. TOKYO, JAPAN	
4	OF 10	LOC	J   A	NO	108-5197
NAME		Product Design Objectives Stacking Connector			
		REV.		A2	

NUMBER 108-5197  
 Customer Release  
 AMP SECURITY CLASSIFICATION

6.4 (Continued):

Test Items	Performance Requirements	Test Methods
Vibration: Para. 6.4.2	Appearance: No abnormalities detrimental to connector functions shall be evident. Discontinuity of Circuit: No electrical discontinuity greater than 1 microsecond shall take place in the tested circuit during the vibration. Termination Resistance, Low Level: Low level termination resistance shall meet Para. 6.2.1.	The test samples are prepared by mating the contact-loaded receptacle connector mounted on a PCB. Test shall be conducted in accordance with specified Test Method 201A of MIL-STD-202, with all the contacts series-wired and 100 mA being applied to the test circuit during the test. (See Fig. 9.) The test vibration shall be as follows. Frequency: Sweeping to change 10-55-10 Hz, reciprocating one cycle a minute. Maximum Amplitude: 1.52mm both sides Direction of Vibration: Three axial directions (X, Y & Z) Duration: Two hours each direction, 6 hours in total
Solderability: Para. 6.4.3	Appearance: More than 95% of the tested surfaces shall appear in continuously sufficient coverage of fresh solder, without concentrated pinholes and voids whose total area shall not exceed 5% of the total tested surfaces.	The test shall be conducted in accordance with Test Method 208 of MIL-STD-202, by immersing the sample in the soldering tub which is controlled at $230 \pm 5^{\circ}\text{C}$ , for 5 seconds.
Soldering Heat Resistivity: Para. 6.4.4	Appearance: After test conditioning, ill affections such as loose of contacts, deterioration of insulation and physical damage etc., shall be not evident.	Test shall be conducted in accordance with Method 210 of MIL-STD-202, by immersing the sample in the soldering tub, which is controlled at $260 \pm 5^{\circ}\text{C}$ . The duration of immersion shall be 10 <sup>+</sup> 1 seconds, and the speed of putting into and take-up from shall be at a rate of $2.54\text{mm} \pm 0.64\text{mm}/\text{second}$ .

(To be continued)

SHEET				AMP (Japan), Ltd.	
				TOKYO, JAPAN	
5	OF	10	LOC	A	NO
			108-5197		REV.
			A <sub>2</sub>		
NAME					
Product Design Objectives					
Stacking Connector					

NUMBER 108-5197

AMP SECURITY CLASSIFICATION  
Customer Release

6.5 Environmental Performance Requirements:

Test Items	Performance Requirements	Test Methods																	
<p>Thermal Shock: Para. 6.5.1</p>	<p>Appearance: No abnormalities detrimental to connector functions shall be evident. Termination Resistance Low Level: Low level termination resistance shall meet Para. 6.2.1.</p>	<p>Test shall be conducted in accordance with Condition A, Method 107D of MIL-STD-202 with the connector mated. The changes of testing temperature shall be as follows:</p> <table border="1" data-bbox="920 472 1496 777"> <thead> <tr> <th>Step</th> <th>Temperature (°C)</th> <th>Duration (Minute)</th> </tr> </thead> <tbody> <tr> <td>1</td> <td>-55 ±</td> <td>30</td> </tr> <tr> <td>2</td> <td>25 ±</td> <td>5 (max.)</td> </tr> <tr> <td>3</td> <td>85 ±</td> <td>30</td> </tr> <tr> <td>4</td> <td>25 ±</td> <td>5 (max.)</td> </tr> </tbody> </table> <p>Repeat temperature changes in Steps 1 through 4 for 5 cycles.</p>			Step	Temperature (°C)	Duration (Minute)	1	-55 ±	30	2	25 ±	5 (max.)	3	85 ±	30	4	25 ±	5 (max.)
Step	Temperature (°C)	Duration (Minute)																	
1	-55 ±	30																	
2	25 ±	5 (max.)																	
3	85 ±	30																	
4	25 ±	5 (max.)																	
<p>Heat Resistivity: Para. 6.5.2</p>	<p>Appearance: No abnormalities detrimental to connector functions shall be evident. Termination Resistance Low Level: Termination resistance low level shall meet Para. 6.2.1.</p>	<p>Test shall be conducted in accordance with Condition B, Method 108 A of MIL-STD-202, with the connectors mated. The testing temperature and duration shall be as follows. Temperature: 85°C Duration: 250 hours</p>																	
<p>Humidity: Para. 6.5.3</p>	<p>Appearance: No abnormalities detrimental to connector functions shall be evident. Termination Resistance Low Level: Termination resistance, low level, shall meet Para. 6.2.1. Insulation Resistance: Insulation resistance shall meet Para. 6.2.2. Dielectric Strength: Dielectric strength shall meet Para. 6.2.3.</p>	<p>Test shall be conducted in accordance with Condition B, Method 103B of MIL-STD-202, with the connectors mated. Humidity testing atmosphere condition shall be as follows: Temperature: 40°C ± 2°C Relative Humidity: 90 ~ 95% Test Duration: 96 hours</p>																	

SHEET				AMP (Japan), Ltd.	
				TOKYO, JAPAN	
6 OF 10	LOC	A	NO	108-5197	REV. A2
NAME Product Design Objectives					
Stacking Connector					

- 7. Test Conditions:
- 7.1 Environmental Conditions:

Unless otherwise specified, all the tests shall be performed in any combination of the following test conditions.

Temperature: 15 ~ 35°C  
 Relative Humidity 45 ~ 75%  
 Atmospheric Pressure: 650 ~ 800mmHg

- 7.2 Test Specimens:
  - 7.2.1 All the samples to be employed by the tests, shall be confirmed for conformance to the applicable product drawing(s).
  - 7.2.2 Unless otherwise specified, all the printed circuit boards to be employed for the tests, shall be conforming to the specification specified in Fig. 8.
  - 7.2.3 Unless otherwise specified, no sample shall be reused.

SHEET				AMP (Japan), Ltd.	
7 OF 10				TOKYO, JAPAN	
LOC	J	A	NO	108-5197	REV.
NAME		Product Design Objectives			
		Stacking Connector			

NUMBER 108-5197  
 CUSTOMER Release  
 AMP SECURITY CLASSIFICATION

8. Test Sequence:

Test Items	Para-graph No.	Sample Groups							
		1	2	3	4	5	6	7	8
Appearance	4.1		1	1	1	1	1		
Termination Resistance Low Level	6.2.1		2, 4	2, 4	2,5,7	2, 4			
Insulation Resistance	6.2.2						2, 5		
Dielectric Strength	6.2.3						3, 6		
Connector Insertion/Extraction Force	6.3.1				3				
Thermal Shock	6.5.1		3						
Heat Resistivity	6.5.2			3					
Humidity	6.5.3				6		4		
Durability	6.4.1				4				
Vibration	6.4.2					3			
Contact Retention Force	6.3.2						7		
Action Pin Insertion Force	6.3.3	1							
Action Pin Retention Force	6.3.4	2	5	5		5			
Solderability	6.4.3							1	
Soldering Heat Resistivity	6.4.4								1

Fig. 6

1. The numbers in the columns indicate the sequence in which tests are performed.
2. Sample Group 1 consists of action pins and printed circuit boards conforming to the specification specified in Fig. 8.
3. Sample Groups 2 and 3 consist of connector mounted on PCB and PCB to which action pins only are mounted.
4. Groups 4 and 5 consist of connector mounted on PCB.
5. Group 6 consists of samples not mounted on PCB.
6. Each Sample Group consists of 4 sets of connectors.

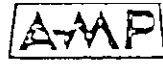
SHEET			AMP (Japan), Ltd. TOKYO, JAPAN	
8 OF 10	LOC J   A	NO 108-5197	REV. A2	
NAME Product Design Objectives Stacking Connector				



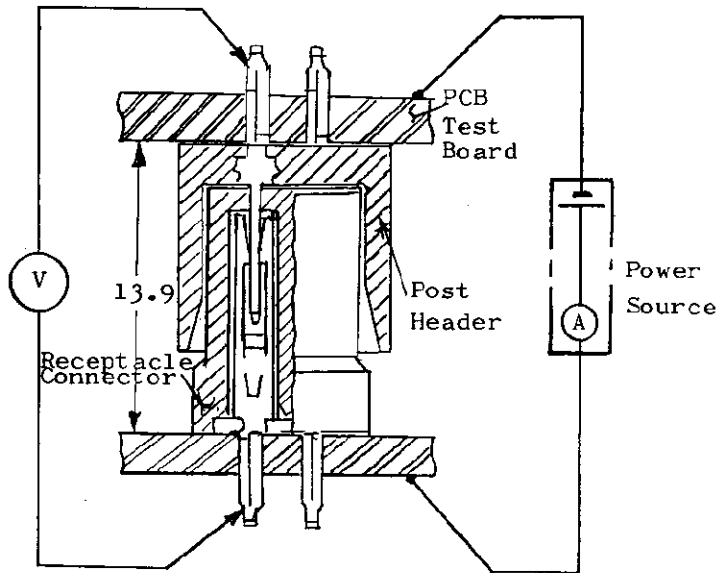

Fig. 7 Measurement of Termination Resistance (Low Level)

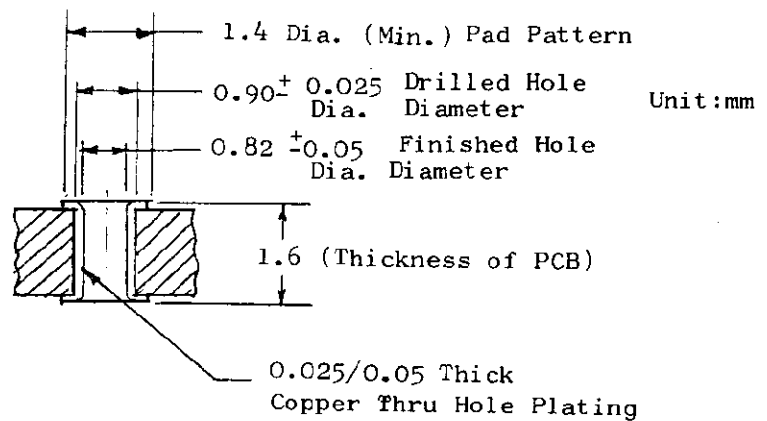
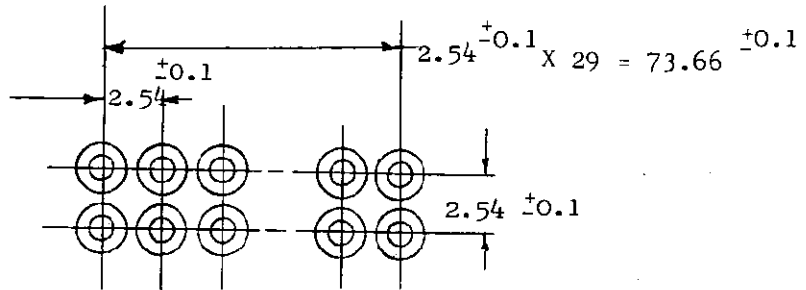

Fig. 8 PCB Test Board Hole Design

SHEET	<b>AMP</b>		AMP (Japan), Ltd.	
9 OF 10			TOKYO, JAPAN	
LOC	J	NO	108-5197	REV.
NAME	A			A2
Product Design Objectives Stacking Connector				

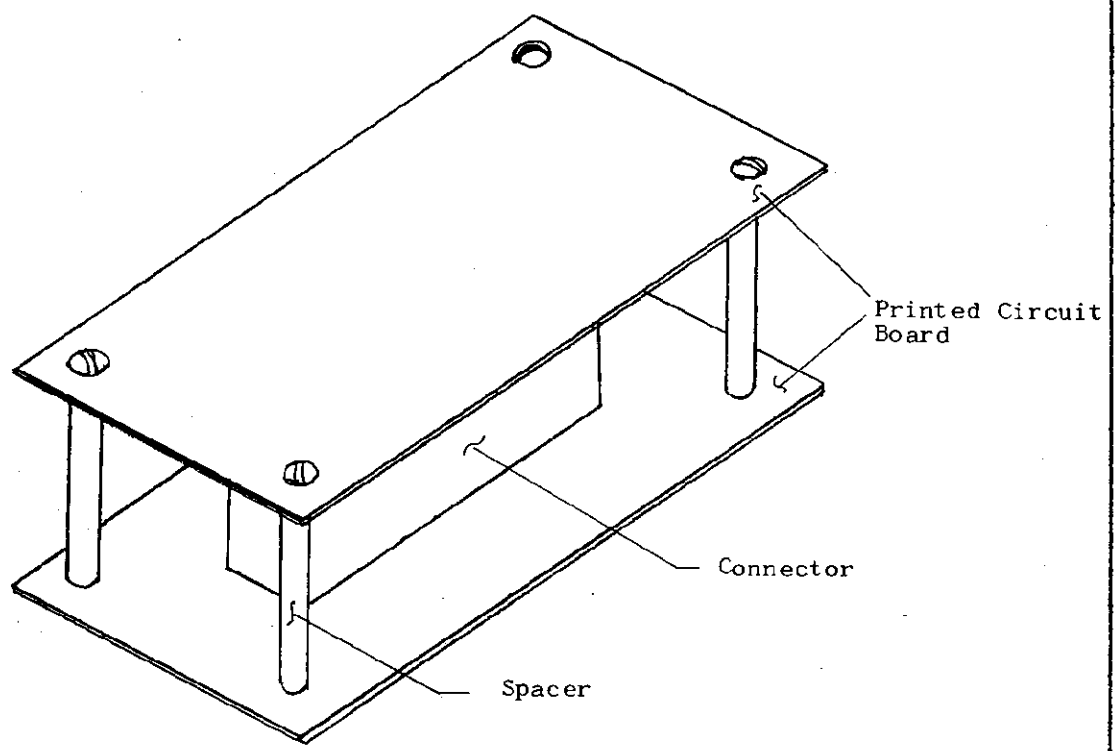

Fig. 9 Mounting Test Connector Sample for Vibration Test

SHEET			AMP (Japan), Ltd. TOKYO, JAPAN	
<u>10</u> OF <u>10</u>	LOC	J   A	NO 108-5197	REV. A2
NAME	Product Design Objectives Stacking Connector			