

---

Combination Connector  
コンビネーション・コネクタ

---

## Contents

First 9 pages following this top sheet : English version  
Next 9 pages : Japanese version

When only one of above versions is supplied to customers, this top sheet shall be attached.

## 目次

このシートに続く最初の 9 ページ : 英語版  
次の 9 ページ : 日本語版

カスタマーに英語または日本語版の片方のみを提出する場合は、このトップシートが必ず添付されなければならない。

## Revision Record (改訂記録)

Revision Letter (改訂記号)	EC number (改訂記録番号)	Date (日付)
C1	FJ00-1038-00	20 JUN 2000
C2		14 APR 2005

## Outline of the latest revision (最新改訂の概要)

Combine two language versions into one document. No change was made on product specification. Change Non-SI unit to SI unit.

2ヶ国語の文書を一括管理とした。仕様内容に変更なし。非 SI 単位を SI 単位に換算。

NUMBER 108-5164

Customer Release  
AMP SECURITY CLASSIFICATION

108-5164

### Design Objectives

#### "250 Series Receptacle and Automotive Positive Lock Receptacle Contacts Combination Connector

1. Scope:

In case when "product specification" is referred to in this document, it should be read as "design objectives" for all times as applicable.

This specification covers product performance requirements and test methods for 2-Position and 5-Position Combination Connectors.

2. Product Numbers and Descriptions:

The products of the following part numbers shall be governed under this specification.

Part No.	Descriptions
170032-2	250 Series, Receptacle
1-170032-2	250 Series, Receptacle
170452-X	250 Series, Positive Lock Receptacle
170454-X	250 Series, Positive Lock Receptacle
170456-X	250 Series, Positive Lock Receptacle
171655-X	250 Series, Receptacle, "M" Type
171656-X	250 Series, Receptacle, "M" Type
172433-X	2-Position, Combination Housing (Parallel Type)
172434-X	2-Position, Combination Housing (T Type)
172558-X	Keying Plug
172559-X	5-Position, Combination Housing (Ignition)
172864-X	2-Position, Combination Housing (Double Lock, "T" Type)
173713-X	2-Position, Combination Housing (Double Lock, Parallel Type)
85069-2	250 Series, Positive Lock Receptacle
85070-2	250 Series, Positive Lock Receptacle

3. Definitions of Terms:

For the purpose of this specification, the following terms shall apply.

3.1 Contact:

Contact is an electrically conductive, metallic component member of a connector which is used after being encapsulated in the housing cavity.

3.2 Housing:

Housing is an electrically insulating, plastic component member of a connector that encapsulates receptacle contacts, loaded in housing cavity.

3.3 Connector:

Connector is an assembly of of a housing and wire-crimped contacts being loaded in housing cavity.

The product described in this document has not been fully tested to ensure conformance to the requirements outlined below. Therefore, AMP Incorporated makes no representation or warranty, express or implied, that the product will comply with these requirements. Further, AMP Incorporated may change these requirements based on the results of additional testing and evaluation. Contact AMP Engineering for further details.

<del>C1</del> Revised FJ00-1038-00	<del>KP</del>	<del>KSL</del>	<del>8/20</del>	<del>10/2</del>	<del>94</del>	DR	tyco Electronics	Tyco Electronics AMP K.K Kawasaki, Japan	
C Revised FJ00-1732-94	SS	YK	10/2	94		CHK			
<del>B2</del> REVISED RFA-1892	<del>AK</del>	<del>AK</del>	<del>10/2</del>	<del>94</del>		APP	LOC	NO	
B1 Revised RFA-1481							J	A	
B Revised RFA-1050							108-5164		
A Revised per RFA-681							REV C2		
SHEET		NAME		Design Objectives					
1 OF 9		250 Series, Combination Connector							
		(250 Series Receptacle & Automotive Positive Lock Receptacle Contacts)							
LTR	REVISION RECORD	DR	CHK	DATE					

4. Material:  
4.1 Contact: Contact shall be made of brass, conforming to Alloy No. 260, ASTM B 36 for 250 series receptacle contact and 250 series receptacle "M" Type, and pre-tinned brass for 250 series, automotive positive lock contact.

4.2 Housing: Housing shall be made of molded Nylon resin conforming to UL 94V-2.

4.3 Tab Contact: (Customer Use) Tab contact used as a counterpart to receptacle contact prepared by the customers, shall be made of 70% copper, 30% tin alloy, conforming to JIS H 3100, C2600P-1/2H, with or without tin-plating.

5. Product Design Feature, Construction and Dimensions:

Product design feature, construction and dimensions shall be conforming to the applicable customer product drawing(s).

5.1 Receptacle Product design feature, construction and dimensions shall be conforming to applicable customer product drawing(s). Receptacle contact shall have proper design for crimping on wire and securely locked in housing position, and also have locking mechanism to maintain stable mating with counterpart tab contact. This locking condition can be easily released by unlocking action as the connector is made to be separated simply by pulling the connector. This locking mechanism is kept in effect so long as the connector is pulled by the crimped wire only.

5.2 Housing: Product design feature, construction and dimensions shall be conforming to applicable customer product drawing(s). "250" series receptacle contacts and 250 series receptacle "M" Type are loaded in housing and securely locked by the aid of housing lance provided in housing cavity. Automotive positive lock receptacle contacts are locked by the housing lance provided in the upper part of cavity which hooks on the edge of rollings of the contact.

6. Applicable Wires and Rating:

6.1 Applicable Wires:

The wires used for crimping contacts shall be conforming to JIS C 3406, Low Voltage Cable for Automobiles, having the sizes as specified in Table 2.

Wire P/N	170032-2	170032-2	170258	170452-X	85069-2 170454-X	85070-2 170456-X	171655-X	171656-X
Wire Size (mm <sup>2</sup> )	0.5-2.0	0.5-2.0	2.0-3.0	0.3-0.5	0.85-2.0	3.0-5.0	0.3-0.5	0.85-2.0
Insulation Diameter (mm)	2.2-3.4	2.2-3.4	3.4-3.8	1.5-2.4	2.2-3.4	3.8-5.0	1.5-2.4	2.2-3.4

Table 2

6.2 Temperature Rating:

Temperature rating of the product connector shall be within the range of -40°C and +105°C. This includes ambient temperature and temperature rising due to energizing the circuit.

SHEET		<b>tyco</b> Electronics		Tyco Electronics AMP K.K Kawasaki, Japan	
2 OF 9		LOC	NO	108-5164	
NAME		J	A	REV. C2	
Design Objectives					
250 Series Combination Connector (250 Series Receptacle & Automotive Positive Lock Receptacle Contacts)					

NUMBER	108-5164		
	7. Performance Requirements and Test Methods: 7.1 Summary of Performance Requirements and Test Methods:		
Customer Release	Test Item (Paragraph No.)	Performance Requirements	Test Methods
	Appearance Confirmation of the Products (Para. 7.1.1)	Products shall be free from the defects such as cracks, breakage, damages, loose of parts, rust and fusion that are detrimental to connector functions.	Visually and tactually inspect the products in accordance with the applicable inspection procedure.
AMP SECURITY CLASSIFICATION	Crimp Tensile Strength (Para. 7.1.2)	Wire Size	Crimp Tensile Strength
		mm <sup>2</sup> (AWG)	(N) (lbs.)
		0.3 (#22)	58.8 (13.2)
		0.5 (#20)	88.3 (19.8)
		0.85 (#18)	127.5 (28.7)
		1.25 (#16)	166.7 (37.5)
		2.0 (#14)	245.2 (55.1)
3.0 (#12)	343.2 (77.2)		
5.0 (#10)	343.2 (77.2)		
		Fasten wire crimped contact on the head of tensile testing machine and apply an axial pull-off load to the wire crimp of the contact by operating the head to travel with the speed at a rate of 100mm a minute. Crimp tensile strength is determined when the wire is broken or is pulled off from the wire crimp.	
Contact Retention Force: (Para. 7.1.3)	Contact retention force shall be 58.8 N minimum.	Fasten contact-loaded connector on the head of tensile testing machine and apply an axial pull-off load to the crimped wire by operating the head to travel with the speed at a rate of 100mm a minute. Measure the force required to dislodge the contact from the loaded position. For this test, wires of 0.85mm <sup>2</sup> or greater shall be used.	
Hinged Locking Retention Force (Including Keying) Para. 7.1.4	Hinged locking to be 58.8 N minimum	Fasten contact-loaded housing with hinged locking device set in effect, on the tensile testing machine, and apply an axial pull-off load to the connector by operating the head to travel with the speed at a rate of 100mm a minute with the locking device set in effect. Measure the force required to dislodge the contact from the loaded position. For this test, the wires of 3mm <sup>2</sup> or greater shall be used.	
Contact Locking Strength: (Para. 7.1.5)	Contact locking strength shall be 98.1 N minimum.	Fill the connector housing <sub>2</sub> with the contacts that are crimped on 1.25mm <sup>2</sup> in size or greater, approximately 100mm long wire. Mate the connector with the tab contact, and fasten on the head of tensile testing machine. Apply an axial pull-off load to the connector by operating the head to travel with the speed at a rate of 100mm a minute with the locking device set in effect. Measure the force required to separate the mated connector with or without the failure or breakage of the locking device.	
Table 3 (To be continued)		SHEET	<b>tyco</b> Electronics
		3 OF 9	Tyco Electronics AMP K.K. Kawasaki, Japan
		LOC	NO
		J A	108-5164
		NAME	REV.
		Design Objectives	
		C2	
		250 Series, Combination Connector (250 Series Receptacle & Automotive Positive Lock Receptacle Contacts)	

7.1 (Continued)

NUMBER 108-5164

Customer Release

AMP SECURITY CLASSIFICATION

Test Item (Paragraph No.)	Performance Requirements	Test Methods											
Connector Insertion/Extraction Force (Para. 7.1.6)	<table border="1"> <thead> <tr> <th rowspan="2">Type</th> <th colspan="2">No. of Pos. Combination Conn.</th> </tr> <tr> <th>2-Pos.</th> <th>5-Pos.</th> </tr> </thead> <tbody> <tr> <td>Insertion N (Max.)</td> <td>58.8</td> <td>98.1</td> </tr> <tr> <td>Extraction N (Min.)</td> <td>9.8</td> <td>29.4</td> </tr> </tbody> </table>	Type	No. of Pos. Combination Conn.		2-Pos.	5-Pos.	Insertion N (Max.)	58.8	98.1	Extraction N (Min.)	9.8	29.4	Contact-loaded connector is mated with counterpart tab contacts and fasten on the head of tensile testing machine, and apply an axial push-in and pull-off load to mate and unmate the connector by operating the head to travel with the speed at a rate of 100mm a minute. For extraction force test, locking device of contact is not set in effect.
Type	No. of Pos. Combination Conn.												
	2-Pos.	5-Pos.											
Insertion N (Max.)	58.8	98.1											
Extraction N (Min.)	9.8	29.4											
Termination Resistance: (Para. 7.1.7)	<p>Termination resistance shall be conforming to the following requirements.</p> <p>Initial: 3mΩ maximum Final: 6mΩ maximum</p>	<p>Contact loaded and mated connector shall be tested by applying test current of 1A (DC) flowing through the circuit as shown in Fig. 1, and measure millivolt drop of the circuit by probing between the points Y and Y', which is 75mm apart from the wire crimp. Termination resistance is obtained by calculation after deducting the resistance of a 75-mm long wire used for termination.</p> 											
Insulation Resistance (Para. 7.1.8)	1,000MΩ minimum	<p>Insulation resistance is tested in accordance with Test Condition B, (500V <math>\pm</math>10% DC), Test Method 302 of MIL-STD-202, by applying test potential between the contacts and the ground as shown in Fig. 2.</p> 											

Table 3 (To be continued)

SHEET		<b>tyco</b> Electronics		Tyco Electronics AMP K.K Kawasaki, Japan	
4	OF	9	LOC	NO	REV.
			A	108-5164	C2
Design Objectives					
NAME 250 Series, Combination Connector (250 Series Receptacle & Automotive Positive Lock Receptacle Contacts)					

7.1 (Continued)

NUMBER  
108-5164

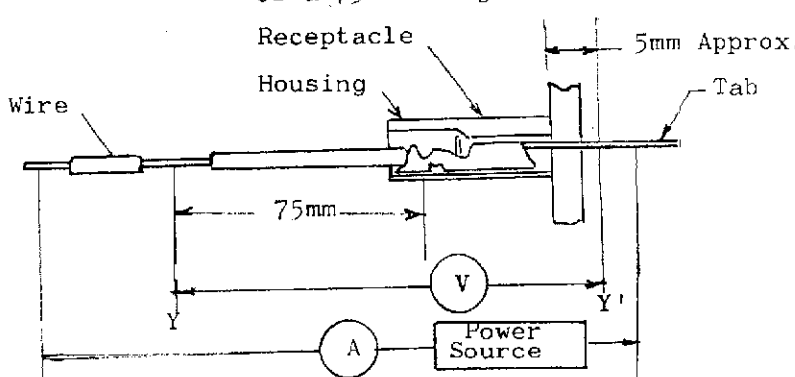
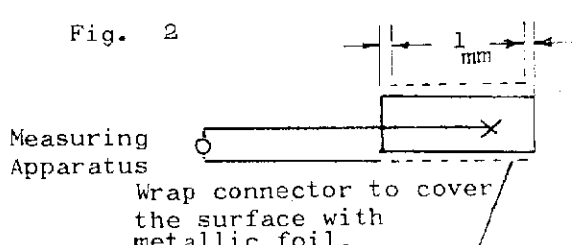
CUSTOMER  
Release

AMP SECURITY  
CLASSIFICATION

Test Item	Performance Requirements	Test Methods
Dielectric Strength (Para. 7.1.9)	No abnormalities shall take place at 2,000V AC applied for 1 minute.	Dielectric strength is tested in accordance with Test Method 301 of MIL-STD-202 by applying test potential of 2,000V AC (RMS) for 1 minute, and inspect if abnormalities such as insulation break-down or flashover took place.
Temperature Rising (Para. 7.1.10)	Temperature rising shall be not greater than 30°C, over the ambient temperature.	Contact-loaded and mated connector assembly shall be tested by applying test current of the specified intensity shown in Table 6, and measured by probing on the wire crimp by using thermocouple, after the temperature rising of the circuit becomes stabilized.
Vibration, Low Frequency: (Para. 7.1.11)	No electrical discontinuity greater than 1 μsec. shall take place during the test. Termination resistance shall be 6mΩ maximum after conditioning.	Contact-loaded and series wired connector shall be tested in accordance with Test Method 202 of MIL-STD-202 by applying vibratile test conditioning of the following magnitude. The test circuit is energized with the test current of 1 ampere DC, and the circuit shall be monitored by using properly arranged measuring apparatus. Vibration Frequency: 10-55-10 Hz., reciprocating one cycle a minute; Amplitude: 1.5mm both sides; Test Duration: 2 hours each for X and Y axes. After conditioning, the sample shall meet the requirements for termination resistance.

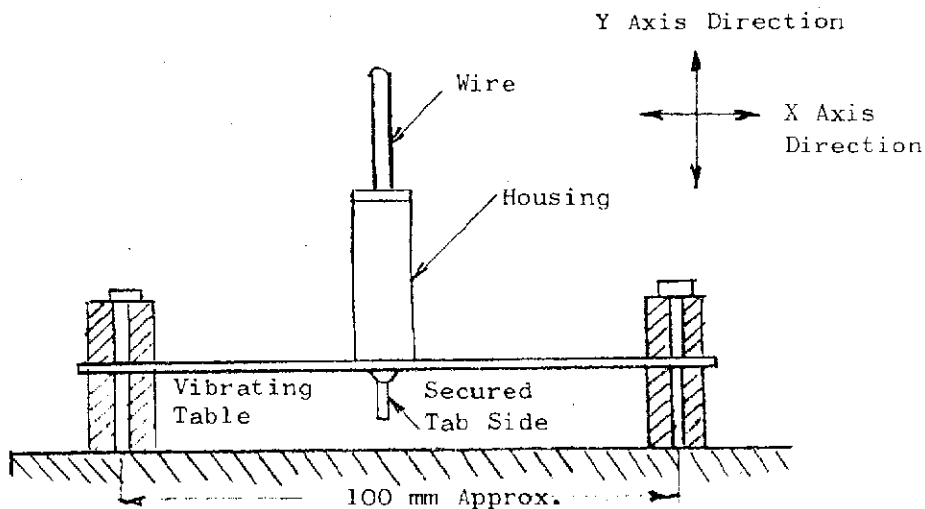

Fig. 3

Table 3  
(To be continued)

SHEET

**tyco**  
Electronics

Tyco Electronics AMP K.K.  
Kawasaki, Japan

5 OF 9

LOC J A

NO

108-5164

REV. C2

NAME

Design Objectives

250 Series, Combination Connector  
(250 Series, Receptacle & Automotive  
Positive Lock Receptacle Contact)

7.1 Performance Requirements and Test Methods (Continued)

NUMBER 108-5164

Customer Release

AMP SECURITY CLASSIFICATION

Test Item (Paragraph No.)	Performance Requirements	Test Methods										
Humidity (Para. 7.1.12)	After humidity conditioning termination resistance shall be 6 mΩ maximum, insulation resistance shall be 100MΩ minimum, and dielectric strength shall be 2000V AC for 1 minute.	Contact-loaded and mated pair of connector shall be tested in accordance with Test Method 106 of MIL-STD-202, by exposing under the test atmosphere of 90-95% relative humidity at 40°C for 96 hours in the test chamber. After completion of test duration, sample shall be tested for termination resistance, insulation resistance and dielectric strength.										
Thermal Shock (Para. 7.1.13)	Termination resistance after test conditioning shall be 6 mΩ maximum.	Contact-loaded and mated pair of connector shall be tested in accordance with Test Condition A, Test Method 107 of MIL-STD-202, by exposing the sample under the specified temperature changes as shown below. After the test duration, the sample shall be tested for termination resistance.										
		<table border="1"> <thead> <tr> <th>Sequence Number</th> <th>Test Conditions</th> </tr> </thead> <tbody> <tr> <td>1</td> <td>105°C +5°C for 30 minutes</td> </tr> <tr> <td>2</td> <td>Room Temperature for 5 minutes</td> </tr> <tr> <td>3</td> <td>-40 ±5°C for 30 minutes</td> </tr> <tr> <td>4</td> <td>Room Temperature for 5 minutes</td> </tr> </tbody> </table>	Sequence Number	Test Conditions	1	105°C +5°C for 30 minutes	2	Room Temperature for 5 minutes	3	-40 ±5°C for 30 minutes	4	Room Temperature for 5 minutes
		Sequence Number	Test Conditions									
		1	105°C +5°C for 30 minutes									
		2	Room Temperature for 5 minutes									
3	-40 ±5°C for 30 minutes											
4	Room Temperature for 5 minutes											
Salt Spray (Para. 7.1.14)	Termination resistance after test conditioning shall be 6 mΩ maximum.	Contact-loaded and mated pair of connector shall be tested in accordance with Test Method 101 of MIL-STD-202 by exposing the sample under the following salt spray test conditioning, and after the test duration, the sample shall be tested for termination resistance and contact locking strength. Salt Concentration: 5% Test Duration: 96 hours										

Table 3 (End)

SHEET		<b>tyco</b> Electronics		Tyco Electronics AMP K.K. Kawasaki, Japan	
6	OF	9	LOC	NO	REV.
			J	A	108-5164
					C2
NAME Design Objectives					
250 Series, Combination Connector (250 Series, Receptacle & Automotive Positive Lock Receptacle Contact)					

7.2 Test Sequence:

NUMBER 108-5164

AMP SECURITY CLASSIFICATION Customer Release

Classification		Test Sequence												
Test Item	Group	Paragraph Number	I	II	III	IV	V	VI	VII					
Confirmation of Appearance, Products		7.1.1						1		1				
Crimp Tensile Strength		7.1.2	1											
Contact Retention Force		7.1.3		1										
Hinged Locking Device Retention Force (Including Keying)		7.1.4			1									
Contact Locking Strength		7.1.5				1								
Connector Insertion Force		7.1.6						2						
Connector Extraction Force		7.1.6						3						
Termination Resistance		7.1.7								2	4	6	8	10
Insulation Resistance		7.1.8						4	7					
Dielectric Strength		7.1.9						5	8					
Temperature Rising		7.1.10					1							
Vibration, Low Frequency		7.1.11								3				
Humidity		7.1.12						6			5			
Thermal Shock		7.1.13										7		
Slat Spray		7.1.14											9	

Table 4

SHEET	<b>tyco</b> Electronics	Tyco Electronics AMP K.K. Kawasaki, Japan	
7 OF 9	LOC J A	NO 108-5164	REV. C2
NAME Design Objectives			
250 Series, Combination Connector (250 Series Receptacle & Automotive Positive Lock Receptacle Contacts)			



8. Quality Assurance Provisions:

8.1 Test Conditions:

Unless otherwise specified, all the tests shall be performed under any combination of the test conditions specified in Table 5.

Ambient Temperature	15 - 35°C
Relative Humidity	45 - 75%
Atmospheric Pressure	86.7~106.7kPa

8.2 Test

8.2.1 Test Specimens:

All the test specimens to be used for the tests, shall be prepared according to conformance to the applicable product drawing(s). The sample preparation shall be done in accordance with AMP Application Specifications, 114-5060, Crimping "250" Series, Positive Lock Receptacle, and 114-5052, Crimping "250" Series, Receptacle Contacts, and 114-5088, Crimping "250" Series, Type "M" Tab and Receptacles, by using the wires of the sizes specified in Table 6.

Unless otherwise specified, no sample shall be reused for the tests.

8.2.2 Number of Samples:

The number of samples to be used for the tests shall be consisting of more than 10 sets for each group of the samples.

8.2.3 Wire Sizes and Test Current:

The wires of the following sizes and composition, and the intensity of the test current shall be used for the tests.

Wire Size		Wire Strands Composition				Applicable Specification	Test Current (A) DC
mm <sup>2</sup>	(AWG)	Calculated Cross-sectional Area	No. of Strands	Diameter of a Strand	Insulation Diameter (mm)		
0.3	(#22)	0.37mm <sup>2</sup>	7	0.26	1.7	—//—	3.0
0.5	(#20)	0.56	7	0.32	2.2	JIS-C-3406	5.0
0.85	(#18)	0.88	11	0.32	2.4	↑	7.0
1.25	(#16)	1.29	16	0.32	2.7		12.0
2.0	(#14)	2.09	26	0.32	3.1		15.0
3.0	(#12)	3.3	41	0.32	3.8	↓	20.0
5.0	(#10)	5.23	65	0.32	4.6	JIS-C-3406	25.0

Table 6

SHEET		<b>tyco</b> Electronics		Tyco Electronics AMP K.K. Kawasaki, Japan	
8 OF 9		LOC	NO	108-5164	
NAME		Design Objectives			
250 Series, Combination Connector (250 Series, Receptacle & Automotive Positive Lock Receptacle Contacts					
		REV.		C2	

8.2.4 Customers' Mating Tab Contact:

The tab contact of the following design shall be used as a counterpart tab contact for evaluation testing of receptacle contacts under this specification.

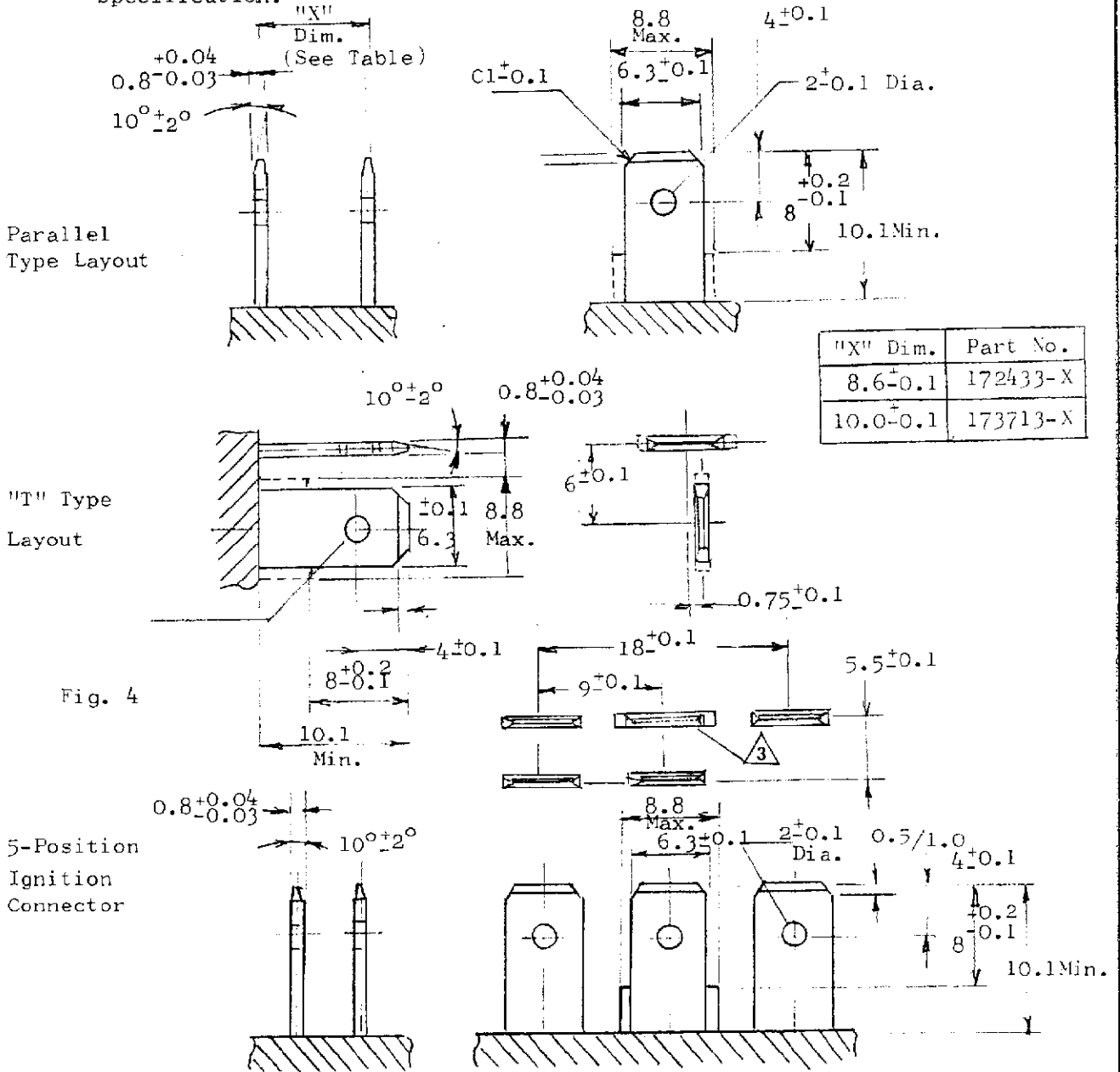

"X" Dim.	Part No.
8.6±0.1	172433-X
10.0±0.1	173713-X

- Notes:
1. Material: 70% Copper, 30% Zinc conforming to JIS H 3100, C2600P-1/2H
  2. Plain tab shall be used for evaluation testing.
- ⚠ For 5-position connector, the shouldered tab can be used only for accepting positive lock contact.

SHEET	<b>tyco</b>		Tyco Electronics AMP K.K.	
	Electronics		Kawasaki, Japan	
9 OF 9	LOC	NO	REV	
	J A	108-5164	C2	
NAME Design Objectives				
250 Series, Combination Connector				
(250 Series Receptacle & Automotive Positive Lock Receptacle Contacts)				

社内標準



管理基準：一般顧客用

(技術標準)

アール・イー・エス・アール(株)

設計目標書

108-5164

コンビネーション・コネクタ

(250シリーズ・リセブタクル及び自動車用ポジティブ・ロック・リセブタクル)

本書中に「本規格は」と引用している箇所はすべて「本設計目標書は」と読み換えて適用願います。

1. 適用範囲

本規格は、2極及び5極のコンビネーション・コネクタについて規定する。

2. 製品の型番及び名称

設計目標書  
 当目標書に基づき性能確認中です。都合により予告なしに性能の変更をさせて頂く場合があります。詳しくは当社技術部へお問い合わせをお願い致します。尚、当社では本目標書で規定される製品がその性能必要条件と合致するかについて保証の責には応じかねます。

型番	名称
171655-□	250シリーズ・リセブタクル“M”タイプ
171656-□	250シリーズ・リセブタクル“M”タイプ
170032-② 1-170032-②	250シリーズ・リセブタクル
170452-□	250シリーズ・ポジティブ・ロック・リセブタクル
170454-□	250シリーズ・ポジティブ・ロック・リセブタクル
170456-□	250シリーズ・ポジティブ・ロック・リセブタクル
172433-□	2極コンビネーション・ハウジング(平行型)
172434-□	2極コンビネーション・ハウジング(T字型)
172558-□	キーイング
172559-□	5極コンビネーション・ハウジング(イグニッション)
172864-□	2極コンビネーション・ハウジング(ダブルロックT字型)
173713-□	2極コンビネーション・ハウジング(ダブルロック平行型)
85069-2	.250シリーズ・ホ°ポジティブ・ロック・リセブタクル
85070-2	.250シリーズ・ホ°ポジティブ・ロック・リセブタクル

3. 用語の意味

本規格に適用する用語の意味は以下の通りとする。

- 3.1 コンタクト：コネクタの構成部品である接触子をいう。
- 3.2 ハウジング：コネクタの構成部品であるコンタクトを収容するものをいう。
- 3.3 コネクタ：電線を圧着したハウジングをアセンブリしたものをいう。

<del>C1 改訂 FJ00-1038-DD</del>	<del>KS</del>	<del>AKIKI</del>	<del>10/25/82</del>	作成：	分類：
<del>C Revised FJ00-1732-94</del>	<del>SS</del>	<del>YK KO</del>	<del>10/25/82</del>	10/25/82	設計目標書
<del>B2 REIKED RFA-1892</del>	<del>AK</del>	<del>91</del>	<del>10/25/82</del>		検閲：
B1 改訂 RFA-1481				承認：	改訂
B 改訂 RFA-1050	A.P.	Y.M.	10/25/82	10/25/82	108-5164
A 改訂 RFA-681					
O 作成 RFA-549				承認：	名称：コンビネーション・コネクタ
改訂 改訂記録	作成	検閲	承認	年月日	(250リセブタクル及び自動車用) ポジティブ・ロック・リセブタクル)

## 4. 使用材料

- 4.1 コンタクト： ASTM B36 COPPER ALLOY 260 に準拠する黄銅条により製造（250 シリーズ・リセプタクル及び250 シリーズ・リセプタクル“M”タイプ）  
 錫めっき済の黄銅により製造（250 シリーズ自動車用ポジティブロック）
- 4.2 ハウジング： 6/6 ナイロン樹脂（94V-2）により製造される。
- 4.3 顧客使用タブ： 7/3 黄銅（JIS-H-3100, C2600-1/2H）めっきなし，または錫めっき付き。

## 5. 構造，形状及び寸法

- 5.1 リセプタクル： 構造，形状，及び寸法は該当する図面に合致していること。電線に圧着された後，ハウジングに收容されて使用されるメス・コンタクトである。ポジティブ・ロック・リセプタクルは，嵌合相手タブコンタクトと固定保持出来るロッキング機構を有する。  
 ロッキング機構を解除するには，レバーを押し下げて引抜けばよい。ロッキング機構は電線が引っぱられた時に作用する構造になっている。
- 5.2 ハウジング： 構造，形状，及び寸法は該当する図面に合致していること。  
 250 シリーズ・リセプタクル及び250 シリーズ・リセプタクル“M”タイプは，ハウジングに設けられたハウジング・ランスにロックし固定保持される。自動車用ポジティブ・ロック・リセプタクルは，上部にあるハウジング・ランスにリセプタクルのローリング部にロックし固定保持される。

## 6. 使用条件

- 6.1 適用電線範囲（JIS-C-3406 自動車用低圧電線）

第 2 表

電線	型番 170032-2 1-170032-2	170258	170452-□	170454-□ 85069-2	170456-□ 85070-2	171655-□	171656-□
電線サイズ (mm <sup>2</sup> )	0.5~2	2~3	0.3~0.5	0.85~2.0	3.0~5.0	0.3~0.5	0.85~2.0
被覆外径 (mm)	2.2~3.4	3.4~3.8	1.5~2.4	2.2~3.4	3.8~5	1.5~2.4	2.2~3.4

## 6.2 使用温度範囲

-40℃ ~ +105℃（周囲温度+通電による温度上昇）

分類： 設計目標書	標準の名称： コンビネーション・コネクタ (250 リセ及び自動車用ポジティブ・ロック・リセ)	標準のコード： 108-5164	改訂 2 頁 C2 9 頁中
--------------	---	---------------------	-------------------

## 7. 性能及び試験方法

## 7.1 性能及び試験方法

第 3 表

項番	試験項目	性能値		試験方法
7.1.1	外観	亀裂，割損，がた，部品のはずれ，錆び，溶解等で機能を損う欠点のないこと。		外観を目視及び触覚により観察し，有害な亀裂，割損，破損，がた，部品のはずれ，錆び，溶解および変形等の有無を確認する。
7.1.2	圧着部引張強度	電線サイズ		適用工具を用いて第 6 表の電線とコンタクトを圧着した試料を作る。但し絶縁被覆部は圧着しない。電線の長さは約 100 mm とし，軸方向に毎分 100 mm の速度で引張り測定する。電線の破断又は圧着部から電線の引抜ける時の値が引張強度である。
		$\text{mm}^2$	強度(最小)	
		(AWG)	(N)	
		0.3	58.8	
		0.5	88.3	
		0.85	127.5	
		1.25	166.7	
2.0	245.2			
3.0	343.2			
5.0	343.2			
7.1.3	コンタクト保持力	58.8 N 最小		コンタクトが装着されたハウジングを引張試験機に固定し，電線を軸方向に毎分 100 mm の速度で引張り，コンタクトがハウジングから抜ける時の値を測定する。但し電線サイズ 0.85 $\text{mm}^2$ 以上の電線を使用する。
7.1.4	2次ロック部保持力 (キーイングも含む)	2次ロック : 58.8 N 最小		コンタクト及び 2 次ロックが装着されたハウジングを引張試験機に固定し電線を軸方向に毎分 100 mm の速度で引張りコンタクトがハウジングから抜ける時の値を測定する。但し電線サイズは 3 $\text{mm}^2$ 以上の電線を使用する。
7.1.5	コンタクト ロック強度	98.1 N 最小		ハウジングに約 100 mm の長さ，1.25 $\text{mm}^2$ 以上の断面積の電線を圧着したコンタクトが組込まれたコネクタを嵌合しロック機構の作用した状態で，タブ側を固定し電線を軸方向に毎分 100 mm の速度で引張り，ロック機構の外れ又は破損して嵌合の外れた時の荷重を測定する。
7.1.6	コネクタ 挿入力 引抜力	2 極コンビネーション 挿入力 58.8 N 最大 引抜力 9.8 N 最小 5 極コンビネーション 挿入力 98.1 N 最大 引抜力 29.4 N 最小		タブコンタクト又はコンタクトが装着されたハウジングを固定し，他方を引張試験機にかけて毎分 100 mm の速度で操作して挿入力，引抜力を測定する。なお，引抜力の場合，コンタクトのロック機構は作用させないで行う。
分類：	設計目標書	標準の名称：	コンビネーション・コネクタ (250 リセ及び自動車用ポジティブ・ロック・リセ)	標準のコード： 108-5164
		改訂	3 頁	C2 9 頁中

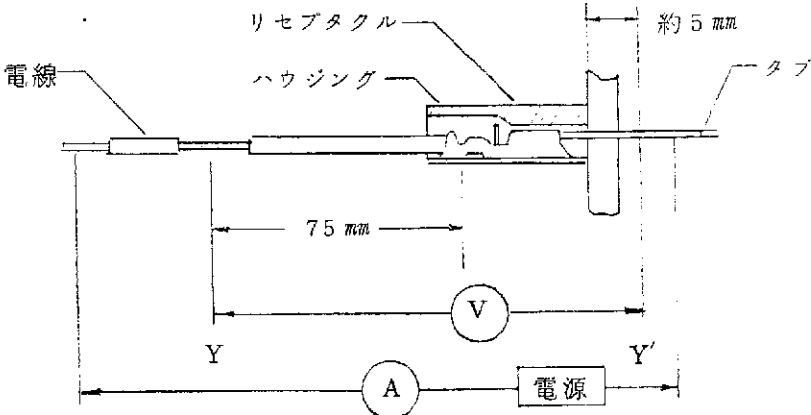
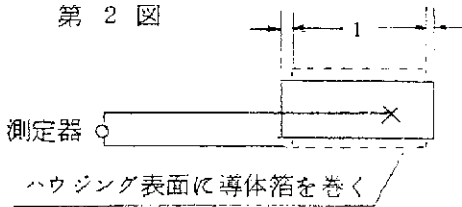
項番	試験項目	性能値	試験方法
7.1.7	総合抵抗	初期 3 mΩ 最大 終期 6 mΩ 最大  第 1 図	コンタクトまたはコネクタを嵌合した状態で1A(DC)の試験電流を通電し、端子の温度が安定した後、圧着部より75 mm離れた点で電圧降下を測定する。(第1図のY-Y'間)総合抵抗はY-Y'間の電圧降下から75 mmの電線の電圧降下を差引いて算出する。  
7.1.8	絶縁抵抗	1000 MΩ 最小	MIL-STD-202, 試験法 302, 条件 B (測定電圧 500VDC±10%) に規定する試験方法によりコンタクト対アース間の絶縁抵抗を測定する。  第 2 図  ハウジング表面に導体箔を巻く
7.1.9	耐電圧	AC 2000V, 1分間にて異常ないこと。	MIL-STD-202, 試験法 301 に規定する試験方法により, 第2図の如くコンタクト対アース間へ AC 2000V (RMS) 1分間印加し, 絶縁破壊, 沿面放電を観察する。

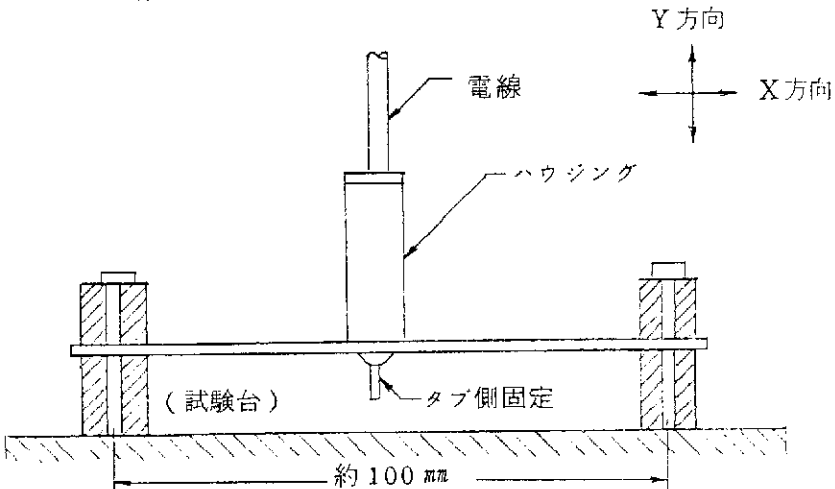
項番	試験項目	性能値	試験方法
7.1.10	温度上昇	30℃最大	<p>コンタクトをハウジングに装着し、タブと嵌合した状態で圧着部に熱電対を固定し、第6表に示す試験電流を流し平衡に達した状態で測定する。</p>
7.1.11	低周波振動	<p>1 <math>\mu</math> sec. を越える電気的不導通のないこと。</p> <p>総合抵抗 6 m<math>\Omega</math> 最大</p> <p>第3図</p> 	<p>コネクタを直列回路になるように接続し、1A(DC)の試験電流を通电してから、MIL-STD-202, 試験法202に規定している下記の条件で試験する。</p> <p>振動数 10-55-10Hz/1分間 両振幅 1.5 mm 試験時間 X,Y軸に各2時間</p> <p>試験後の試料は、総合抵抗を満足すること。</p>
7.1.12	耐湿性	<p>総合抵抗 6 m<math>\Omega</math> 最大 絶縁抵抗 100 M<math>\Omega</math> 最小 耐電圧 AC2000V 1分間</p>	<p>MIL-STD-202, 試験法106に規定する下記の条件により、嵌合した状態で試験する。</p> <p>温度 40℃ 湿度 90~95% 時間 96時間</p> <p>試験後の試料は、総合抵抗、絶縁抵抗耐電圧を満足すること。</p>
分類： 設計目標書	標準の名称： (250リセ及び自動車用ポジティブ・ロック・リセ)	コンビネーション・コネクタ 標準のコード： 108-5164	改訂 5頁 C2 9頁中

項番	試験項目	性能値	試験方法										
7.1.13	熱 衝 撃	総合抵抗 6 mΩ 最大	<p>MIL-STD-202, 試験法 107, 試験条件 A に規定する下記の条件により嵌合した状態で試験する。 試験後の試料は, 総合抵抗を満足すること。</p> <table border="1"> <thead> <tr> <th>試験順序</th> <th>試験方法</th> </tr> </thead> <tbody> <tr> <td>1</td> <td>105±5℃ 0.5時間</td> </tr> <tr> <td>2</td> <td>室温 5分以内</td> </tr> <tr> <td>3</td> <td>-40±5℃ 0.5時間</td> </tr> <tr> <td>4</td> <td>室温 5分以内</td> </tr> </tbody> </table>	試験順序	試験方法	1	105±5℃ 0.5時間	2	室温 5分以内	3	-40±5℃ 0.5時間	4	室温 5分以内
試験順序	試験方法												
1	105±5℃ 0.5時間												
2	室温 5分以内												
3	-40±5℃ 0.5時間												
4	室温 5分以内												
7.1.14	塩 水 噴 霧	総合抵抗 6 mΩ 最大	<p>MIL-STD-202, 試験法 101 に規定する下記の条件により, 嵌合した状態で試験する。</p> <p>濃 度 5 % 時 間 96時間</p> <p>試験後の試料は, 総合抵抗, コンタクト・ロック強度を満足すること。</p>										
<p>分類： 設計目標書</p> <p>標準の名称： コンビネーション・コネクタ (250リセ及び自動車用ポジティブ・ロック・リス)</p> <p>標準のコード： 108-5164</p> <p>改訂 C2</p> <p>6 頁 9 頁中</p>													



## 7.2 試験順序

第 4 表

区 分		試 験 順 序											
項 目	グループ	項 目	I	II	III	IV	V	VI		VII			
			外 観	7.1.1						1		1	
圧着部引張強度	7.1.2	1											
コンタクト保持力	7.1.3		1										
2次ロック部保持力 (キーイングも含む)	7.1.4			1									
コンタクトロック強度	7.1.5				1							11	
コネクタ挿入力	7.1.6						2						
コネクタ引抜力	7.1.6						3						
総 合 抵 抗	7.1.7								2	4	6	8	10
絶 縁 抵 抗	7.1.8						4	7					
耐 電 圧	7.1.9						5	8					
温 度 上 昇	7.1.10					1							
低 周 波 振 動	7.1.11								3				
耐 湿 性	7.1.12						6			5			
熱 衝 撃	7.1.13										7		
塩 水 噴 霧	7.1.14											9	

分類：

設計目標書

標準の名称：

コンビネーション・コネクタ  
(250リセ及び自動車用ポジティブ・ロック・リセ)

標準のコード：

108-5164

改訂

C2

7 頁

9 頁中

## 8. 品質保証条件

## 8.1 試験条件

特に指定のない場合は、第5表に示す下記の環境条件のもとで性能試験を行うものとする。

第5表

温度	15～35℃
相対湿度	45～75%
気圧	86.7～106.7kPa

## 8.2 試験

## 8.2.1 試料

性能試験に用いる試料は、該当製品図面に合致したものであり、第6表に示す電線に「250 シリーズ・ポジティブ・ロック・リセプタクル取付適用規格114-5060, 250 リセプタクル取付適用規格114-5052及び250 シリーズ" M "型タブ及びリセプタクル取付適用規格114-5088」に基づいて圧着した試料であること。いずれの試料も特に規定しない限り、再度試験に用いてはならない。

## 8.2.2 試料数

性能試験に用いる試料数は各グループ毎に10セット以上とする。

## 8.2.3 使用電線及び試験電流

性能試験に用いる電線及び試験電流は、第6表の通りである。

第6表

電線サイズ mm <sup>2</sup> (AWG)	電線構成			電線規格	試験電流 A (DC)
	計算断面積	本数/径	被覆径		
0.3 (#22)	0.37 mm <sup>2</sup>	7/0.26	1.7 mm	#	3
0.5 (#20)	0.56	7/0.32	2.2	JIS-C-3406	5
0.85 (#18)	0.88	11/0.32	2.4	↑	7
1.25 (#16)	1.29	16/0.32	2.7		12
2.0 (#14)	2.09	26/0.32	3.1		15
3.0 (#12)	3.3	41/0.32	3.8	↓	20
5.0 (#10)	5.23	65/0.32	4.6		JIS-C-3406

8.2.4 相手タブ

性能試験に用いる相手タブは、第4図に示す寸法のものを使用すること。

第4図

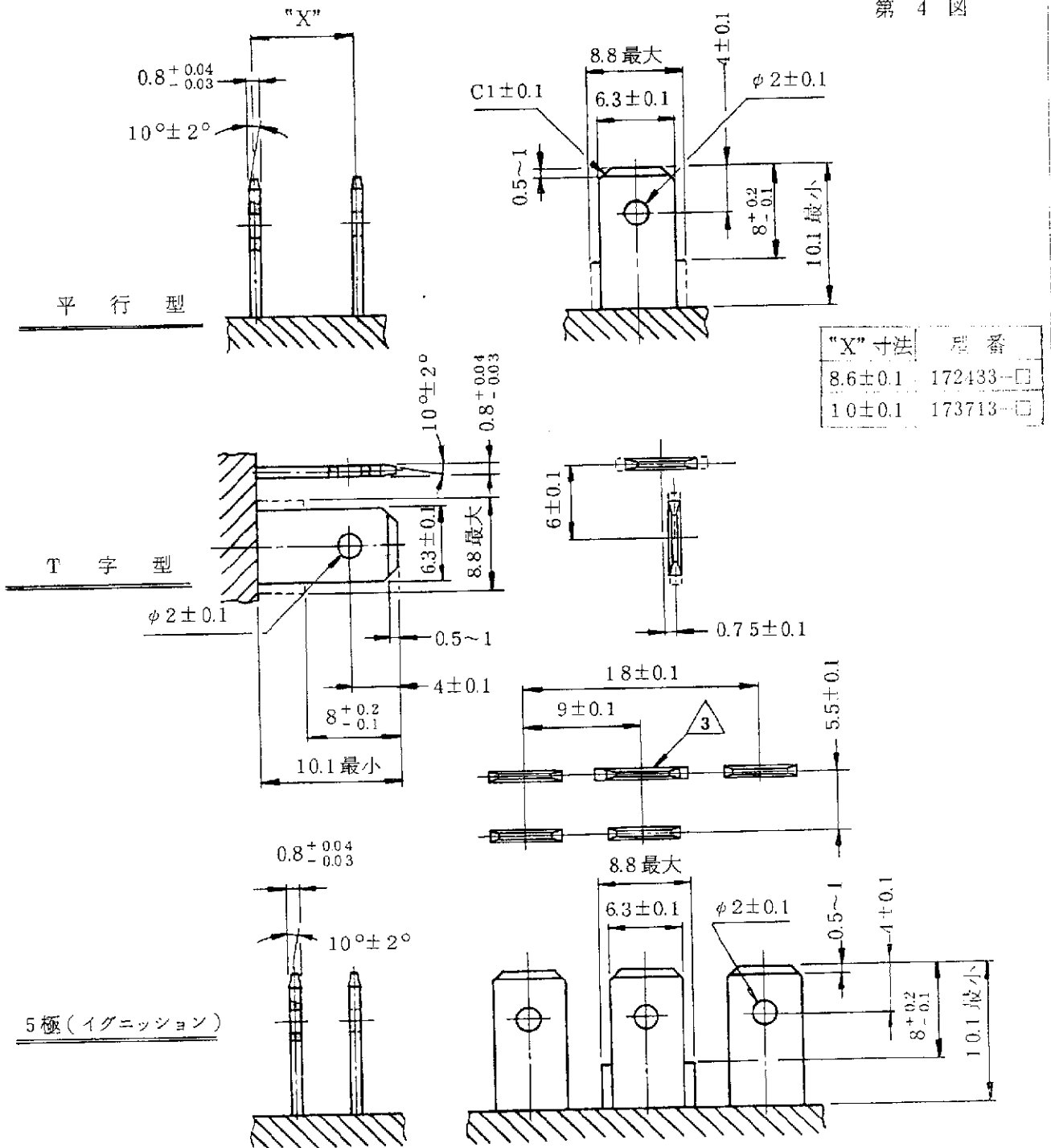

"X"寸法	型番
$8.6 \pm 0.1$	172433-□
$10 \pm 0.1$	173713-□

- 注 1. タブの材料は7/3黄銅 (JIS-H-3100, C2600P-1/2H)  
 2. めっきなしタブを使用すること。  
 ③ 5極についてショルダー付タブ使用ヶ所はポジティブ部分のみ。