Wire Tap/Splice Connector

1. SCOPE

1.1. Content

This specification covers performance, tests and quality requirements for the Tyco Electronics Wire Tap/Splice Connector.

1.2. Qualification

When tests are performed on the subject product line, procedures specified in Figure 1 shall be used. All inspections shall be performed using the applicable inspection plan and product drawing.

1.3. Qualification Test Results

Successful qualification testing on the subject product line was completed on 02Aug05. The Qualification Test Report number for this testing is 501-613. This documentation is on file at and available from Engineering Practices and Standards (EPS).

2. APPLICABLE DOCUMENTS

The following documents form a part of this specification to the extent specified herein. Unless otherwise specified, the latest edition of the document applies. In the event of conflict between the requirements of this specification and the product drawing, the product drawing shall take precedence. In the event of conflict between the requirements of this specification and the referenced documents, this specification shall take precedence.

2.1. Tyco Electronics Documents

- 109-197: AMP Test Specifications vs EIA and IEC Test Methods
- 114-13151: Application Specification
- 501-613: Qualification Test Report

2.2. Industry Standard

EIA-364: Electrical Connector/Socket Test Procedures Including Environmental Classifications

3. REQUIREMENTS

3.1. Design and Construction

Product shall be of the design, construction and physical dimensions specified on the applicable product drawing.

3.2. Materials

Materials used in the construction of this product shall be as specified on the applicable product drawing.

3.3. Ratings

- Voltage: 600 volts AC
- Current: 7 amperes maximum
- Temperature: -55 to 105°C

3.4. Performance and Test Description

Product is designed to meet the electrical, mechanical and environmental performance requirements specified in Figure 1. Unless otherwise specified, all tests shall be performed at ambient environmental conditions per EIA-364.

3.5. Test Requirements and Procedures Summary

Test Description	Requirement	Procedure
Initial examination of product.	Meets requirements of product drawing.	EIA-364-18. Visual and dimensional (C of C) inspection per product drawing.
Final examination of product.	Meets visual requirements.	EIA-364-18. Visual inspection.
ELECTRICAL		
Low level contact resistance.	5 milliohms maximum initial. 15 milliohms maximum final.	EIA-364-23. Subject specimens to 100 milliamperes maximum and 20 millivolts maximum open circuit voltage. See Figure 3.
Withstanding voltage.	1 minute hold with no breakdown or flashover.	EIA-364-20, Condition I. 1000 volts AC at sea level. Test between specimens and lead shot.
Temperature rise vs current.	10°C maximum temperature rise at specified current.	EIA-364-70, Method 1. Stabilize at a single current level until 3 readings at 5 minute intervals are within 1°C.
MECHANICAL		
Vibration, random.	No discontinuities of 1 microsecond or longer duration. See Note.	EIA-364-28, Test Condition VII, Condition D. Subject mated specimens to 3.10 G's rms between 20 to 500 Hz. Fifteen minutes in each of 3 mutually perpendicular planes. See Figure 4.

Figure 1 (continued)

Test Description	Requirement	Procedure
Mechanical shock.	No discontinuities of 1 microsecond or longer duration. See Note.	EIA-364-27, Method H. Subject mated specimens to 30 G's half-sine shock pulses of 11 milliseconds duration. 3 shocks in each direction applied along 3 mutually perpendicular planes, 18 total shocks. See Figure 4.
Wire insertion force.	3 pounds maximum.	Measure force necessary to insert wire into wire trap at a maximum rate of 1 inch per minute.
Wire retention force.	10 pounds minimum.	Measure force necessary to remove wire from wire trap at a maximum rate of 1 inch per minute.
ENVIRONMENTAL		
Thermal shock.	See Note.	EIA-364-32, Test Condition VII. Subject specimens to 5 cycles between -55 and 105°C.
Humidity-temperature cycling.	See Note.	EIA-364-31, Method III. Subject specimens to 10 cycles (10 days) between 25 and 65°C at 80 to 100% RH.
Temperature life.	See Note.	EIA-364-17, Method A, Test Condition 4, Test Time Condition C. Subject mated specimens to 105°C for 500 hours.

NOTE

Shall meet visual requirements, show no physical damage, and meet requirements of additional tests as specified in the Product Qualification and Requalification Test Sequence shown in Figure 2.

Figure 1 (end)

3.6. Product Qualification and Requalification Test Sequence

Test or Examination	Test Group (a)				
	1	2	3	4	5
	Test Sequence (b)				
Initial examination of product	1	1	1	1	1
Low level contact resistance	3,6	2,4	2,4		
Withstanding voltage				2,5	
Temperature rise vs current					2
Vibration, random	4				
Mechanical shock	5				
Wire insertion force	2				
Wire retention force	7				
Thermal shock				3	
Humidity-temperature cycling			3	4	
Temperature life		3			
Final examination of product	8	5	5	6	3

NOTE

- (a) See paragraph 4.1.A.
- (b) Numbers indicate sequence in which tests are performed.

Figure 2

4. QUALITY ASSURANCE PROVISIONS

4.1. Qualification Testing

A. Specimen Selection

Specimens shall be prepared in accordance with applicable Instruction Sheets and shall be selected at random from current production. Each test group shall consist of 5 specimens.

B. Test Sequence

Qualification inspection shall be verified by testing specimens as specified in Figure 2.

4.2. Requalification Testing

If changes significantly affecting form, fit or function are made to the product or manufacturing process, product assurance shall coordinate requalification testing, consisting of all or part of the original testing sequence as determined by development/product, quality and reliability engineering.

4.3. Acceptance

Acceptance is based on verification that the product meets the requirements of Figure 1. Failures attributed to equipment, test setup or operator deficiencies shall not disqualify the product. If product failure occurs, corrective action shall be taken and specimens resubmitted for qualification. Testing to confirm corrective action is required before resubmittal.

4.4. Quality Conformance Inspection

The applicable quality inspection plan shall specify the sampling acceptable quality level to be used. Dimensional and functional requirements shall be in accordance with the applicable product drawing and this specification.

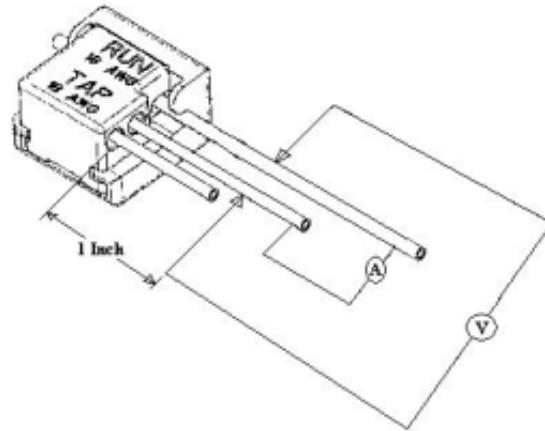

Figure 3
Low Level Contact Resistance Measurement Points

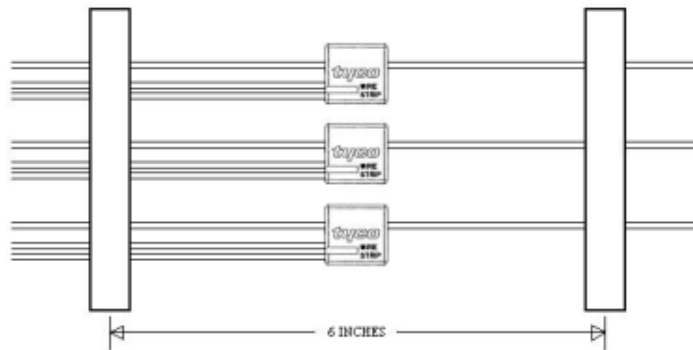

Figure 4
Vibration & Mechanical Shock Mounting Fixture