

DUOPLUG 2.5 Female Connector, Standard version
Acc. to IEC 60335-1 rev.4, GWT 750°C No Flame
UL 94V-0 rated plastic material

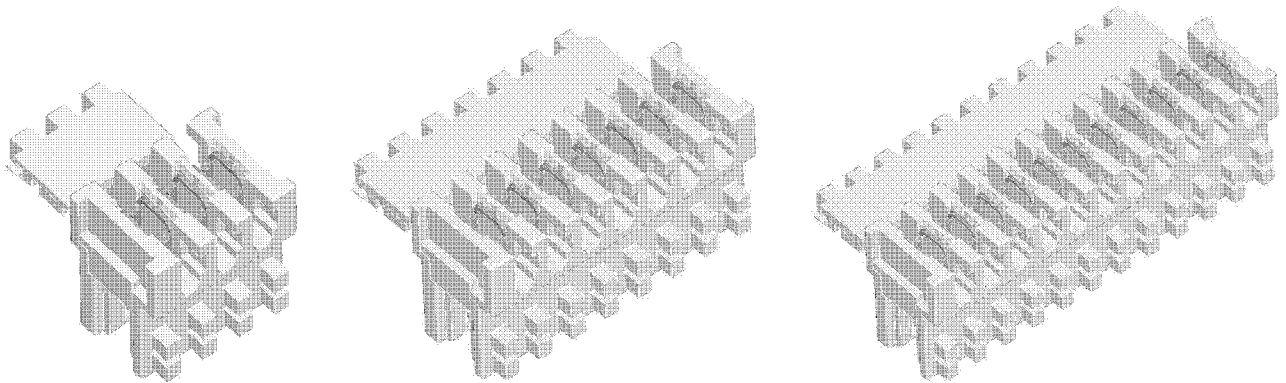

Product Code: 1150

GPL: 405

A1	REVISED	R.F.	21 FEB 08	GT	21 FEB 08
A	RELEASED	R.F.	15 DEC 06	GT	15 DEC 06
1	FIRST ISSUE	R.F.	06 JUL 06	GT	06 JUL 06
rev letter	rev. record	DR	Date	CHK	Date
DR. R. FABRIS	DATE 06/july/2006	APVD G. TURCO			DATE 06/july/2006

This specification is a controlled document.

This information is confidential and is disclosed to you on condition that no further disclosure is made by you to other than AMP personnel without written authorization from AMP Italia.

Page 1 of 16

* Trademark of AMP Incorporated

LOC I

1 SCOPE

1.1 Content

This specification covers the performance, tests and quality requirements for DUOPLUG 2.5 Female connector, Standard version, acc. to IEC 60335-1 rev.4 GWT 750°C No Flame, UL 94V-0 rated plastic material.

DUOPLUG 2.5 Female connector, Standard version

<i>P/N</i>	0-293 207-3	Selectively loaded connector
	0-293 207-7	Selectively loaded connector
	0-293 207-9	Selectively loaded connector, keyed
	1-293 207-1	Selectively loaded connector

1.2 Qualification

When tests are performed the following specified specifications and standards shall be used.

All inspections shall be performed using the applicable inspection plan and product drawing.

This specification assures the performances, the tests and the quality of this product, totally or partially according at the "RAST 2,5" standard.

2 APPLICABLE DOCUMENTS

The following documents form a part of this specification to the extent specified herein. In the events of conflict between the requirements of this specification and the product drawing or of conflict between the requirements of this specification and the referenced documents, this specification shall take precedence.

2.1 Tyco Documents

A	109-sr:	Tyco General Requirements for Test Specifications
B	Customer Drawings:	P/N see item 1.1
C	114-18049-1	Application Specification
D	108-20238:	Product Specification

2.2 Other Documents

A.	DIN 72551 (Rev. 02/72)	Electrical cables, thermoplastic insulated dimensions.
B.	VDE 0627 (Rev. 09/91)	Connector and plug-and-socket devices for rated voltages up to 1000Va.c./d.c. and rated currents up to 500A for each pole.
C.	IEC 60112 (Rev. 06/94)	Method for determining the comparative and the tracking indices
D.	IEC 60352-3-4 (Rev. 11/95) and IEC 60352-4 (Rev. 09/94)	Testing For Insulation Displacement Connection
E.	IEC 60998-1/,-2,-3 (rev.90-04/91-10)	Connecting devices for low-voltage circuits for household and similar purposes; Part 2-3 Insulation piercing connecting devices
F.	IEC 60695-2-11	Fire hazard testing, Part 2-11: Glow/Hot wire based test methods – Glow wire flammability test method for end-products
G.	IEC 60068-2-6 (Rev '95)	Environmental testing – vibration sinusoidal
H.	IEC 60512-1-1	Connectors for electronic equipment - Tests and measurements – Part 1-1: General examination, Test 1a: Visual examination
I.	IEC 60512-3	Current carrying capacity tests
J.	IEC 60512-2-1	Contact Resistance in dry circuit
K.	IEC 60512-11-9	Temperature Life
L.	IEC 60512-11-12	Humidity & Temperature Cycling
M.	IEC 60512-2-2	Contact Resistance At Specified Current

N.	IEC 60512-4-1	Voltage stress test; Part 4a: Voltage proof
O.	IEC 60512-5-1	Temperature Rise Versus Current
P.	IEC 60512-4-1	Withstanding Voltage
Q.	EIA 364 –TSB	Salt Spray Corrosion
R.	IEC 60512-13-1	Mating & Unmating Force
S.	IEC 60512-16-4/16-20	Wire Termination tensile Strength
T.	RAST2.5	Raster Anschluss Steck Technik 2.5mm Teilung
U.	IEC 60335-1 rev.4	Household and similar electrical appliances - Safety Part 1: General requirements

3 GENERAL REQUIREMENTS

3.1 Design and construction

Product shall be of the design, construction and physical dimensions specified on the applicable production drawing.

3.2 Materials

Descriptions for material see in production drawings.

3.3 Ratings

- A Voltage: 3 ÷ 63V AC (fully loaded contacts at 2,5 mm pitch)
3 ÷ 250V AC (selectively loaded contacts at 5,0 mm pitch)
- B Current carrying capability: 2A max.
- C Temperature: -40°C to +110°C (increase due to current load included, see Derating Curve shown on picture 1)
- D Degree of protection: IP 00
- E Durability: 10 cycles

3.4 Performance and Test Description

The product is designed to meet the electrical, mechanical and environmental performance requirements specified in §3.5. All tests are performed at following ambient environmental conditions unless otherwise specified:

Preparation for all Test Groups:

Storage 1 day at 50% rel. Umidity

Acc. IEC 68 Part 1.

Temperature: 25 ± 10°C

Rel. Humidity: 45 ÷ 75%

Air pressure: 860 ÷ 1060 mbar

3.5 Test requirements and procedures summary

VISUAL INSPECTION		
Test Description	Requirement	Procedure
VISUAL AND DIMENSIONAL EXAMINATION	Meets requirements of product drawing.	Acc. to IEC 60512-1-1

ELECTRICAL INSPECTIONS		
Test Description	Requirement	Procedure
CURRENT CARRYING CAPACITY	See applicable Derating curve (Pictures 6)	Acc. to IEC 60512-3
MAX TEMPERATURE RISE OF INSULATION DISPLACEMENT DEVICE (IDC)	$\Delta T \leq 45^{\circ}\text{C}$	Acc. to IEC 60998 Part 1 Test 15 Current: 5A Wire sect: 0.35 mm ²
MAX TEMPERATURE RISE OF CONTACTS	$T \leq 110^{\circ}\text{C}$	Acc. to VDE 0627, test 6.2.7 Ambient temp.: 85°C Current: 2A
VOLTAGE PROOF	Value and nature of the test voltage: 1500V (2500V for selectively loaded)	Acc. to IEC 60512-4-1, Test 4a Testing: 60s
INSULATION RESISTANCE	Value and nature of the test voltage: 500V DC Initial value: 10MΩ min Final value: 5MΩ min	Acc. IEC 60998 Part 1, Test 13.3 Testing: 60s
CONTACT RESISTANCE	Initial value: $\leq 10\text{m}\Omega$	Acc. to IEC 60512-2-2 Current: 1A See picture 10) for method
IDC VOLTAGE DROP	Initial value: $\leq 5\text{ mV/A}$	Acc. IEC 60998 Part 2-3, Test 15.101.A Current: 1A See picture 11) for method

MECHANICAL INSPECTIONS		
Test Description	Requirement	Procedure
ENGAGING AND SEPARATING FORCE (Contact)	1 st In: 6 N max/way 10 th Out: 0.5 N min/way	Acc. To IEC 60512-13-1 Testing speed: 25mm/min Displacement: 4 mm. Gage: see picture 7
MATING AND UNMATING FORCE (Connector)	1 st In: 8 N max/way 1 st Out: 3 N min/way 10 th Out: 2 N min/way	Acc. To IEC 60512-13-1 Testing speed: 25mm/min Displacement: 4 mm. Gage: see pictures 2-3
CONTACT RETENTION IN CAVITY	Retention value: 20N min.	Acc. To IEC 60512-15-8 Testing speed: 25mm/min Displacement: 4 mm. Steel gage: 1.65x2.0 mm.
TERMINATION TENSILE STRENGTH	Tensile force: 30N min.	Acc. To IEC 60512-16-4 and 16-20 Testing speed: 25mm/min See picture 8) for method

MECHANICAL INSPECTIONS		
Test Description	Requirement	Procedure
COVER TENSILE STRENGTH	Tensile force: 20N min.	Acc. To IEC 60512-16-4 and 16-20 Testing speed: 25mm/min See picture 9) for method
POLARIZATION METHOD	Mating force : 20N	Acc. To VDE 0627 Test 5.9.1
DURABILITY	No physical damage <u>Contact resistance</u> : difference between Initial and Final value must be $\leq 5m\Omega$ <u>IDC Voltage drop</u> : difference between Initial and Final value must be $\leq 5mV/A$	Acc. To VDE 0627, Test 6.2.8 Number of cycles: 10
WIRE MOVEMENT	No unpermissible shift or break near the wire contact. <u>Contact resistance</u> : difference between Initial and Final value must be $\leq 5m\Omega$	Acc. To IEC 60998 part 2-3 Test 14.101.1
VIBRATION TEST	No more than 1 μ s micro interruptions admitted. <u>Contact resistance</u> : difference between Initial and Final value must be $\leq 5m\Omega$	Acc. IEC 60068-2-6, Mil STD 1344 A Current: 100mA Time length: 8h for axis

ENVIRONMENTAL INSPECTIONS		
Test Description	Requirement	Procedure
THERMAL CYCLING	No physical damage. <u>Contact resistance</u> : difference between Initial and Final value must be $\leq 5m\Omega$ <u>IDC Voltage drop</u> : difference between Initial and Final value must be $\leq 5mV/A$	Acc. IEC 60998 Part 2-3, Test 15.101, test A $T_{min}=+30^{\circ}C$; $T_{max}=+85^{\circ}C$ Current: 2A Number of cycles: 192
SATURATED ATMOSPHERE IN THE PRESENCE OF SULFUR DIOXYDE (KESTERNICH)	<u>Contact resistance</u> : difference between Initial and Final value must be $\leq 5m\Omega$	Acc. To DIN 50 018-0.2S Temperature: $+40^{\circ}C$ 0.2 dm ³ SO ₂ 2 dm ³ H ₂ O Duration time: 8 hours
SALT SPRAY CORROSION	No physical damage. <u>Contact resistance</u> : difference between Initial and Final value must be $\leq 5m\Omega$	Acc. To EIA 364-TSB (was TYCO 109-24) Temperature= $+35^{\circ}C$ Relative humidity: 95% NaCl concentration: 50g/l Duration time: 96 hours
DAMP	No physical damage <u>Contact resistance</u> : difference between Initial and Final value must be $\leq 5m\Omega$	Acc. To IEC 60998 part 2-3 Test 12.2 Temperature: 20-30 $^{\circ}C$ Humidity: 91-95% Duration: 48 hours

ENVIRONMENTAL INSPECTIONS		
Test Description	Requirement	Procedure
DRY-HEAT	No physical damage Contact resistance: difference between Initial and Final value must be $\leq 5m\Omega$	Acc. To IEC 60512-11-9 Temperature: 110°C Duration: 7 days
COLD	No physical damage Contact resistance: difference between Initial and Final value must be $\leq 5m\Omega$	Acc. To IEC 60512-11-10 Temperature: -40°C Duration: 2 hours
BALL PRESSURE TEST	Imprinting $\varnothing \leq 2mm$.	Acc. IEC 60998-1, Test 16.3 Temperature: 125°C Duration: 1 hour
GLOW WIRE TEST	Housing material according to IEC 60335-1 rev.4 (connection carrying > 0.2 A, unattended appliances)	Acc. IEC 60335-1 rev.4 (see annex O for detail)
TRACKING INDEX PROOF	PTI 250 V	Acc. IEC 60112, Test A

Qualification and requalification test sequence

TEST	Test group (1)																
	A	B	C	D	E	F	G	G1	H	J	K	L	M	N	P	Q	
	Test sequence (2)																
Visual and dimensional examination	1	1		1-9	1-7	1-5	1	1		1-5	1-9	1-5	2	2		1-4	
Current carrying capacity		2															
Max temperature rise (IDC)									1								
Max temperature rise (Contact)		3															
Voltage proof		5	7								6						
Insulation resistance					3-6						5						
Contact resistance		3-5	1-4	2-6	2-5	2-4				2-4	3-7	2-4					
IDC Voltage drop		2-6									2-8						
Engaging/separating force (Contact)																2	
Mating/unmating force (Connector)	2																
Contact retention in cavity	5																
Termination tensile strength							2										
Cover tensile strength								2									
Polarization method	3																
Durability	4	4														3	
Wire movement						3											
Vibration										3							
Thermal cycling											4						
Kesternich												3					
Salt spray corrosion					4												
Damp			5														
Dry Heat			4														
Cold			3														
Ball pressure test													1				
Glow wire test														1			
Tracking Index Proof															1		

- 1) See §4.1 A
- 2) Numbers indicate sequence in which tests are performed

4 QUALITY ASSURANCE PROVISIONS

4.1 Qualification Testing

A Sample selection

The samples shall be prepared in accordance with product drawings. They shall be selected at random from current production.

Test groups shall consist of:

Test group	CONNECTORS	
	N° of positions	Quantity
A	3+7+11	5+5+5
B	3+7+11	3+3+3
C	9	5
D	See note 1	See note 1
E	See note 1	See note 1
F	3	3
G	3+7+11	5+5+5
G1	3+7+11	5+5+5
H	7	3
J	See note 2	See note 2
K	See note 2	See note 2
L	See note 2	See note 2
M	3+7+11	5+5+5
N	3+7+11	5+5+5
P	3+7+11	5+5+5
Q	3+7+11	5+5+5

All the connectors, unless otherwise required, shall be crimped with 30cm long wires.

Note 1: n°1 PCB with all inserted connectors as expected in final appliance.

Note 2: n°2 PCB with all inserted connectors as expected in final appliance.

B Sample selection

Qualification inspection shall be verified by testing samples as specified in §3.6.

4.2 Requalification Testing

If changes significantly affecting form, fit, or function are made to the product or to the manufacturing process, of which negative influence of the product quality cannot be excluded, product assurance shall coordinate requalification testing, consisting of all or part of the original testing sequence as determined by development/product, quality and reliability engineering.

4.3 Acceptance

Acceptance is based on verification that the product meets the requirements of §3.5. Failures attributed to equipment, test setup, or operator deficiencies shall not disqualify the product. When product failure occurs, corrective action shall be taken and samples resubmitted for qualification. Testing to confirm corrective action is required before resubmittal.

4.4 Quality conformance inspection

The applicable Tyco Electronics quality inspection plan will specify the sampling acceptable quality level to be used. Dimensional and functional requirements shall be in accordance with the applicable product drawing and this specification.

PICTURE 1)

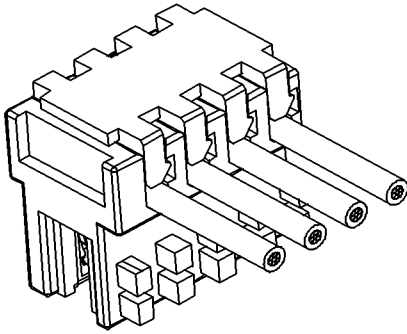

Standard connector

PICTURE 2)

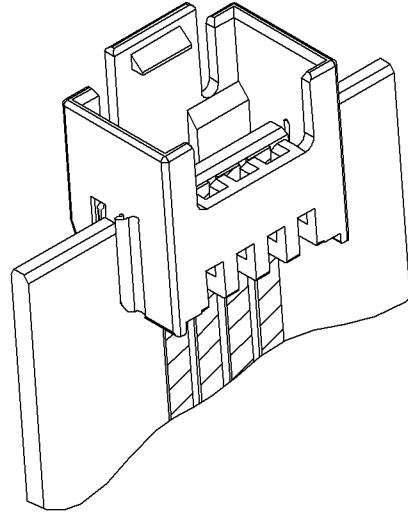

PCB frame

PICTURE 3)

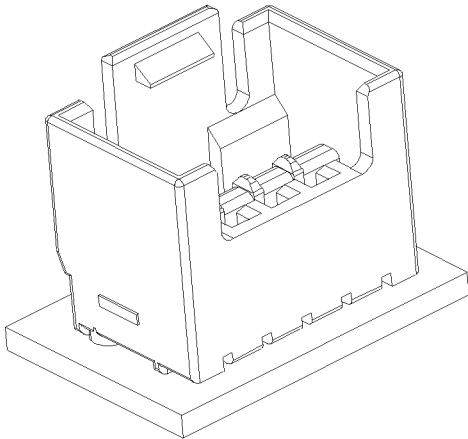

Tab header

PICTURE 4)

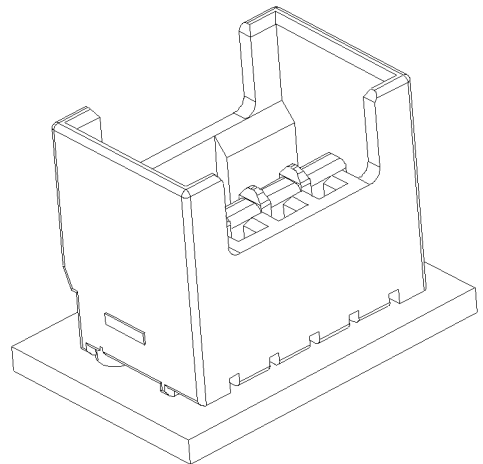

Tabheader for feed through wiring

PICTURE 5) PCB layout for frame version (ref. Picture 2)

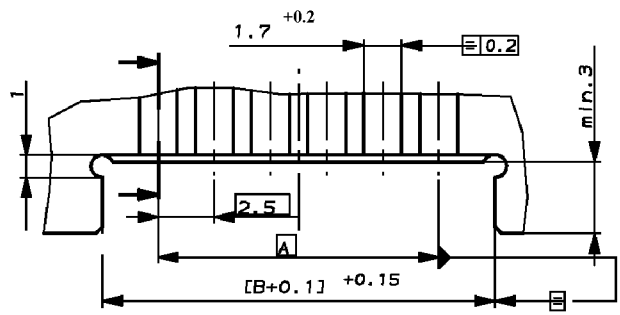
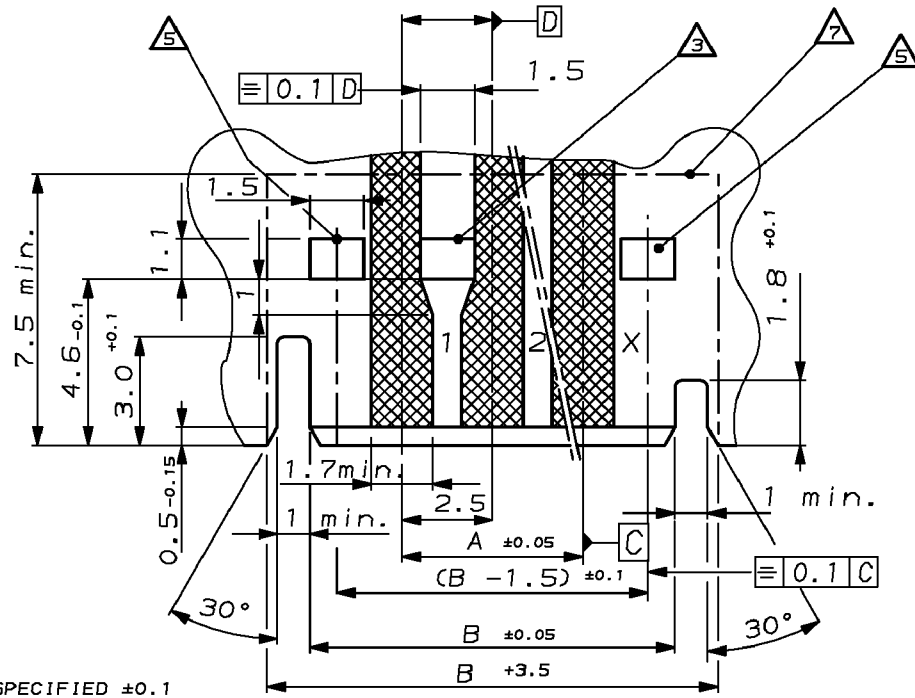

20	47.5	52.4	52.5
19	45	49.9	50
18	42.5	47.4	47.5
17	40	44.9	45
16	37.5	42.4	42.5
15	35	39.9	40
14	32.5	37.4	37.5
13	30	34.9	35
12	27.5	32.4	32.5
11	25	29.9	30

10	22.5	27.4	27.5
9	20	24.9	25
8	17.5	22.4	22.5
7	15	19.9	20
6	12.5	17.4	17.5
5	10	14.9	15
4	7.5	12.4	12.5
3	5	9.9	10
POS. POLZAHL	DIM A MAß A	DIM B MAß B	DIM C MAß C

- 1 Base material quality: FR-3, FR-4
- 2 PCB thickness: $1,5 \pm 0,14$ (Base material incl. Copper cladding, single or double sided)
- 3 Copper coating thickness: 35-70 μm
- 4 Plating: 5-20 μm electrodeposited Sn or SnPb 60/40-93/7 or equivalent HAL treatment
- 5 No Ni underplating

PICTURES 6)

AMP DUOPLUG 2.5

Female connector – PCB frame connection

- Female part (PN) : 1-293 207-1
- Contactmaterial : CuSn, tin-preplated
- Wire size : 0,22 mm²; 7-stranded wires
- PCB (compare picture 5)
- PCB material : FR4 / 5-10 µm electrodeposited tinned
- Housing : 11 pos.
- Test setup : 3 PCB´ s with inserted female connector, one sided PCB

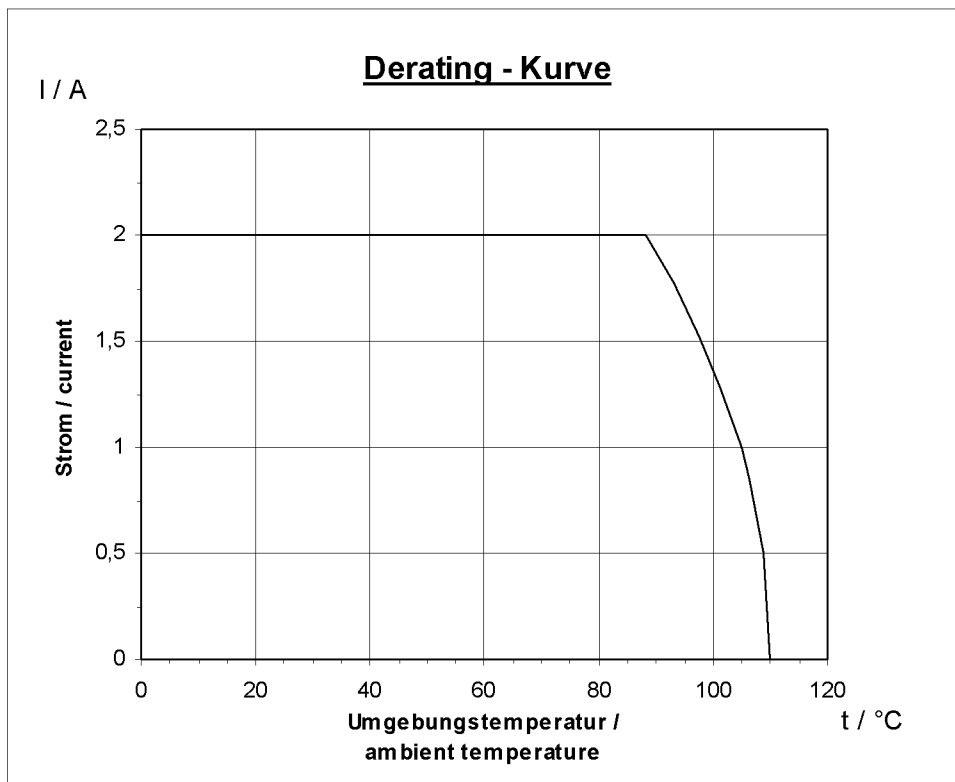

AMP DUOPLUG 2.5
Female Connector – Tabheader connection

Female part (PN)	: 1-293 207-1
Contactmaterial	: CuSn, tin-preplated
Wire size	: 0,22 mm ² ; 7 -stranded wires
Pin (PN)	: 1-829 867-1 (Tabheader)
PCB-material	: brass, tinned
Housing	: 11 pos.
Test setup single sided	: 3 PCB´ s with tabheader and inserted female connector, PCB: Tabheader soldered

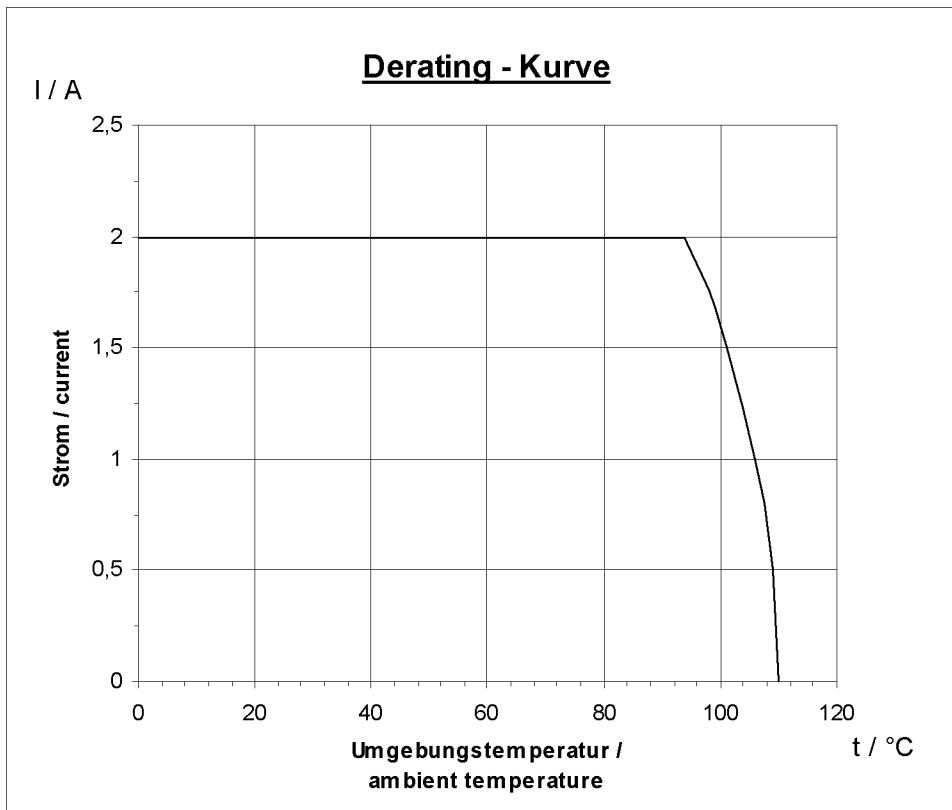

PICTURE 7)

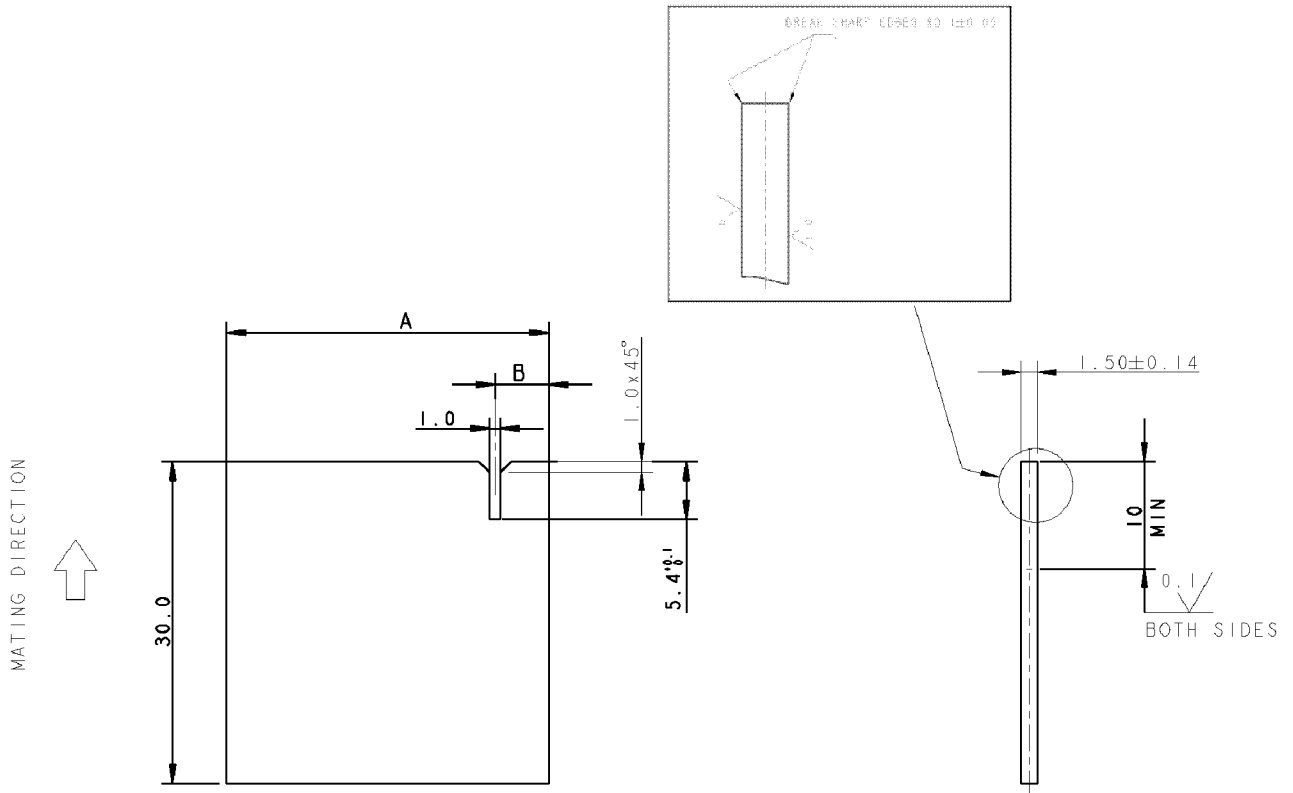

- 1 Material : Stainless steel, Hardened Rockwell C 50-55
- 2 Finish : Only designated surface shall be finished

5.0	30.0	12
5.0	25.0	10
5.0	22.5	9
5.0	20.0	8
5.0	17.5	7
5.0	15.0	6
5.0	12.5	5
2.5	10.0	4
5.0	7.5	3
B	A	Conn. Pos.

PICTURE 8)

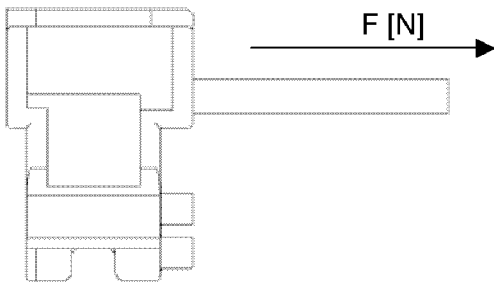

90° to mating direction

PICTURE 9)

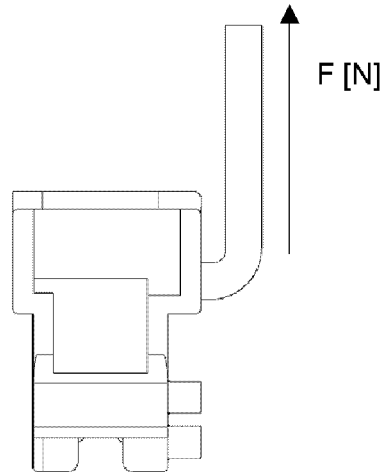

180° to mating direction

PICTURE 10)

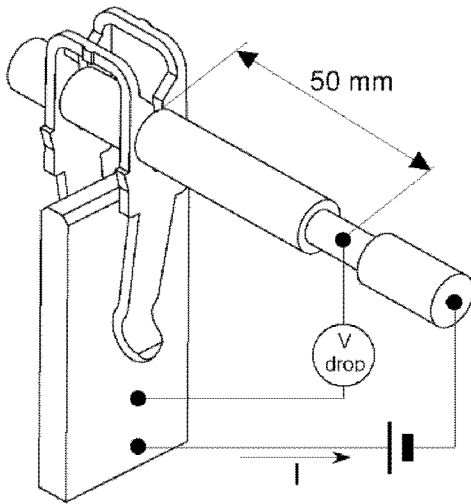

PICTURE 11)

