

## ELCON Mini cable-to-board power connector system, Four Position

**NOTE**

*The product may not perform according to the product specification if precautions have not been taken in the application to provide mechanical stability of the connector in relation to its mating parts*

**1. SCOPE**

## 1.1. Content

This specification covers the performance, test and quality requirements for the ELCON Mini four position cable connector plug and four mating board mount connectors. The cable connector plug assembly is used to connect to the pc-board connector assembly (by means of front panel connection, or internal cabling). A cable connector plug consists of: 4 position housing suitable for standard- and power-timer contacts, latch.

The cable connector plug mates to a four position male board connector (right angle or straight), fixed with a latch device, through the front panel, or in internal cabling applications.

## 1.2. Qualification

When tests are performed on subject product, procedures specified in this product specification shall be used. All inspections shall be performed using applicable inspection plan and product drawing.

**2. APPLICABLE DOCUMENTS**

The following documents form a part of this specification to the extent specified herein. Unless otherwise specified, the latest edition of the document applies. In the event of conflict between the requirements in this specification and the product drawing, the product drawing shall take precedence. In the event of conflict between requirements of this specification and the referenced documents, this specification shall take precedence.

## 2.1. TE Documents

- 501-19184 Test report. Cable/Board Power Connector assy. Cable connector
- 114-32039 Application specification Cable/Board Power Connector System. (Right angle or straight)
- 114-18037 Application specification Standard Power Timer Contact
- 108-18025 Product specification Standard Power Timer Contact.
- TEC-109-201 Test-specification, Component Heat Resistance to Lead-Free Reflow Soldering.

**3. REQUIREMENTS**

## 3.1. Design and Construction

Products shall be of design, construction and physical dimensions as specified on the applicable customer product drawings C-2173211, C-2173132 C-2173200, and C-2173168.

## 3.2. Materials and Finish

- Housings, cable connector - Glass filled high temp thermoplastic, color black, UL 94V-0.
- Housings, board connector - Glass filled high temp thermos plastic, color black, UL 94V-0.
- Contacts, power - Copper alloy, silver plated.

3.3. Ratings

<b>Operating voltage</b>	500V DC/AC
<b>Current</b>	22 Ampere max. Per contact when used with 14AWG cable (with shield) <sup>[1]</sup> 25 Ampere max. Per contact when used with 12AWG cable (without shield) 30 Ampere max. Per contact when used with 10AWG cable (without shield) <sup>[2]</sup>
<b>Operating temperature</b>	-40°C to 125°C.
<b>Durability</b>	50 cycles.



**NOTE**

*Connectors are applied to solder with cables.*

<sup>[1]</sup> *Solder with 8AWG cables*

<sup>[2]</sup> *Solder with 10AWG cables*

3.4. Performance and Test Description

The product is designed to meet mechanical and environmental performance specified in this paragraph as tested per test sequence specified in Section 3.5. Unless otherwise specified, all tests are performed at ambient environmental conditions per IEC specification 60068-1 clause 5.3 and are performed with connectors in mated condition.

VISUAL		
Test Description	Performance Requirements or Severity	Procedures
Examination of product	Meets requirements of product drawing and applicable instructions on customer drawing, instruction sheet, and application specification.	Visual, dimensional and functional per applicable inspection plan.

Table 1

<b>ELECTRICAL</b>		
Termination resistance power contacts	Max. open voltage 20mV. Max. current 100 mA DC. All contacts to be ensured. Measuring points shall be as (1) indicated in Figure 1 Requirement: 3,0 m $\Omega$ max. initial (excluding bulk resistance) 3,0 m $\Omega$ max. final (excluding bulk resistance)	IEC 60512-2-1
Termination resistance Shielding contacts (for shielded part only)	Max. open voltage 20mV. Max. Current 100 mA DC. All contacts to be measured. Measuring points shall be as (2) indicated in Figure 2 Requirement: 10 m $\Omega$ max. initial 20 m $\Omega$ max. final.	IEC 60512-2-1
Insulation resistance	Test voltage 100V DC or AC peak. Duration: 1 minute. Test between adjacent contacts. Requirement: 5x10 <sup>3</sup> M $\Omega$ min. initial 10 <sup>3</sup> M $\Omega$ min. final	IEC 60512-3-1
Voltage proof	Test voltage 1120 Vrms for adjacent contacts unmated Duration 1 minute. Test is applicable for unmated board-connector (p.n. 2173211-1) and unmated cable-connector (p.n. 2173168-1) Requirement: no break-down or flash-over	IEC 60512-4-1
Temperature rise	Requirement: Temperature rise is 30 $\rightarrow$ C maximum over ambient temperature.	IEC 60512-5-1 test 5a
Electrical load and temperature	Oven temperature: 85 $\rightarrow$ C Current: 22 Ampere max. Per contact when used with 14AWG cable (with shield) 30 Ampere max. Per contact when used with 10AWG cable (without shield) Duration: 500 hrs Requirement: Temperature rise is 35 $\rightarrow$ C maximum over ambient temperature.	IEC 60512-9-2
Shield contact spring force (for shielded part only)	Deflect the spring until A=0,26mm (see figure 3), at speed of 10mm/min. Requirement: Contact -force 1,0N minimum.	TE-internal lab-procedures
Vibration Sinusoidal	10-500 sweeping 1 oct./min. displacement 0,75mm peak-acceleration: 10g 30 minutes in each of 3 mutual perpendicular axes. Requirement: no discontinuity > 1 $\mu$ sec. (power-contacts and shielding-contacts) no Physical damage.	IEC 60512-6-4

Table 2

<b>MECHANICAL</b>		
<b>Test Title</b>	<b>Severity Requirements</b>	<b>Procedure</b>
Physical shock	Subject connector to 50 g half sine Shock pulses of 11 ms duration. 6 shocks in each of 3 mutual Perpendicular axes. Requirement: no discontinuity > 1 %sec. (power-contacts and shielding-contacts) no physical damage.	IEC 60512-6-3
Insertion/withdrawal forces No latch	Mate and un-mate connector-pair Speed: 10 mm/min. Rest: 30 s min. Requirement: Total mating force 80 N max. Total un-mating force 20 N min	IEC 60512-13-2
Insertion forces during wrong polarization.	Apply 250 N straight force at the cable connector, in mating direction during 10 Sec. Requirement: no physical damage. no electrical connection is made between power-contacts.	IEC 60512-15-1
Latch activation force (for shielded part only)	Apply force as shown in figure 4 Compression 0,5mm Requirement: maximum force needed to open latch: 25N	TE lab-procedures.
Mechanical operation	Mate and un-mate connector-pair Rate: 500 cycles/hour. Speed: 10 mm/s Operation cycles: 50 total Requirement: no functional damage	IEC 60512-9-1
Contact retention force in cable connector.	Apply 50 N straight force at a contact of the cable connector, in un-mating direction during 10 sec. Requirement: Max. displacement 0,2 mm	IEC 60512-15-1
Side-load (4 directions individually) (for shielded part only)	Cable connector mated on board connector. Apply force (as shown in figure 5) of 40 N, in each of the directions shown separately, during 10 sec. requirement: No functional damage, latch should be In place.	IEC 60512-17-3
Locking latch strength	Apply 100 N straight force at the mated cable connector, in un-mating direction. requirement: No functional damage, latch should be In place.	IEC 60512-15-1
Mounting force board connector.	Measure the force necessary to push the board-connector into the host PCB Rate 10mm/min PCB-hole-layout as specified on customer-draw 2173211-C requirement: 20N max.	

Cable Pull Out Crimp Force Ferrule	Apply 80N straight force at the cable, while fixating the die-cast shells of the cable-connector. requirement: no displacement of cable and ferrule with respect to the cable connector shells no functional damage to crimped connection between cable and cable connector shells.	IEC 60512-15-1
------------------------------------	--	----------------

Table 3

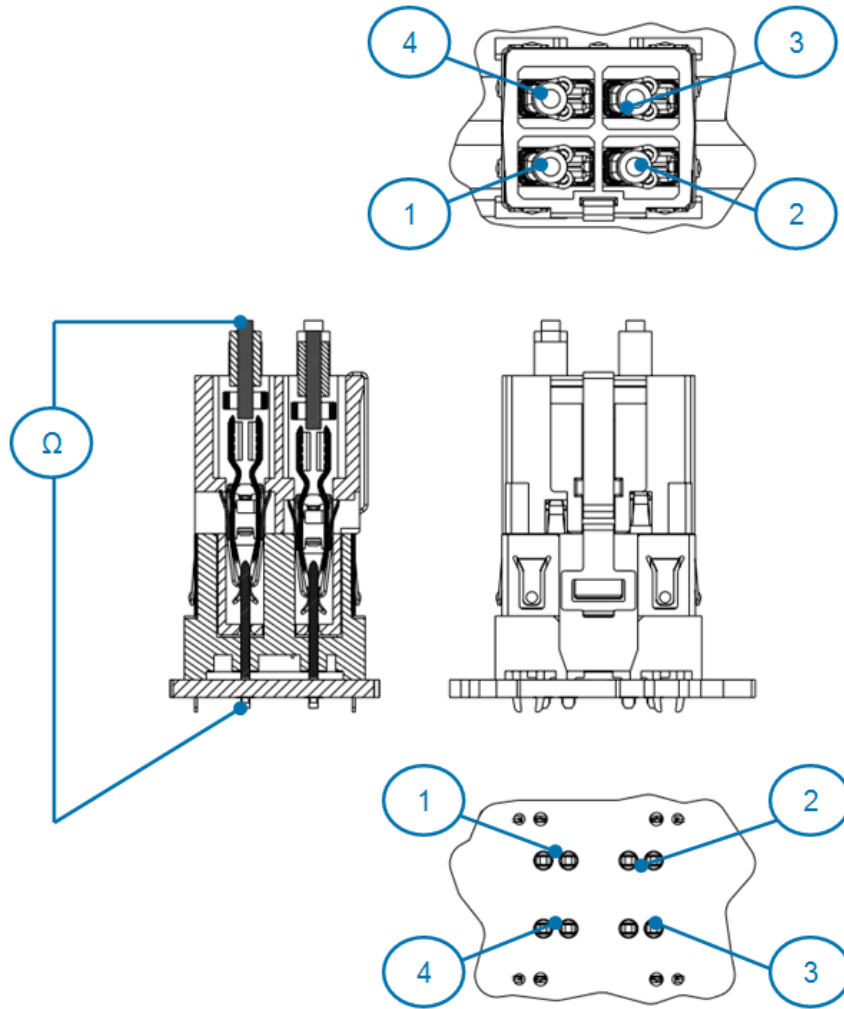
<b>ENVIRONMENTAL</b>		
<b>Test Title</b>	<b>Performance / Severity Requirements</b>	<b>Procedure</b>
Rapid change of Temperature.	-40°/90°C, 0,5 hrs / 0,5 hrs, 5 cycles	IEC 60512-11-4.
Climatic sequence	Dry heat 90° C, 16 Hrs 1st damp heat cycle 25°/55° C, RH 93 % 24 Hrs Cold -40° C Two Hrs 2nd Damp heat cycle 25° /55° C RH 93% 24 Hrs	IEC 60512-11-1
Damp/heat steady state	Temperature 40°C, RH 93%; duration: 21 days	IEC 60512-11-3
Resistance to soldering heat board connector	Specimens were subject to the reflow profile. Shown in Figure 6.	TE 109-201, Method C

Table 4

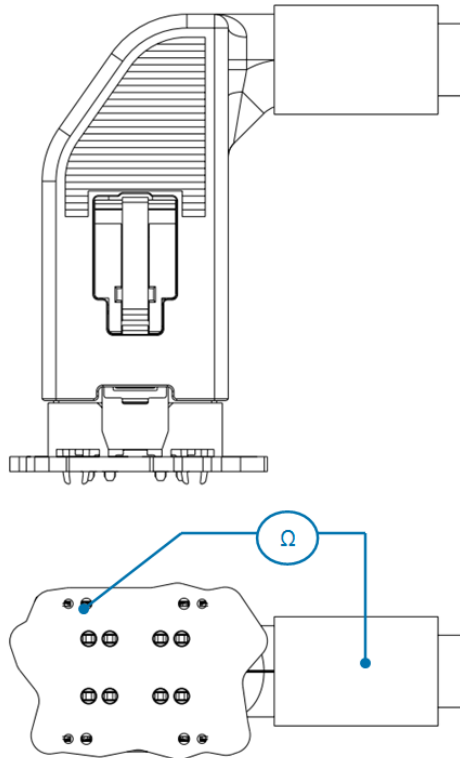


**NOTE**

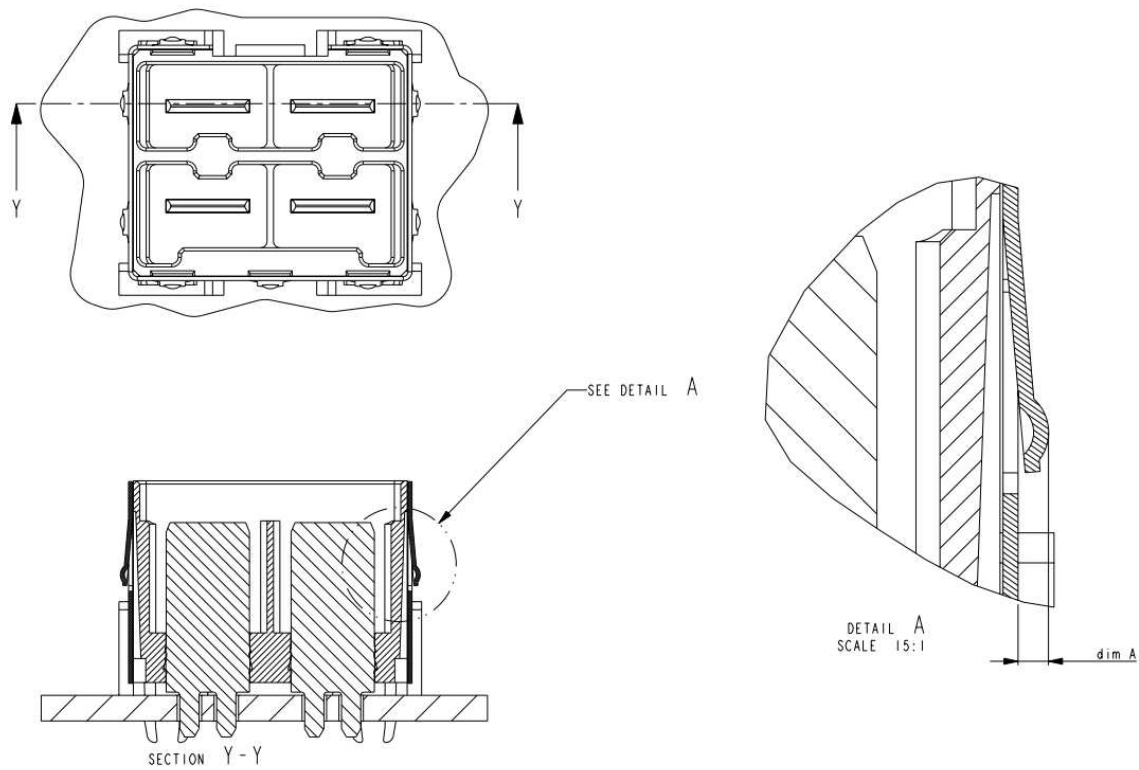
*Shall meet visual requirements, show no physical damage, and meet requirements of additional tests as specified in the Product Qualification and Requalification Test Sequence shown in Table 5.*



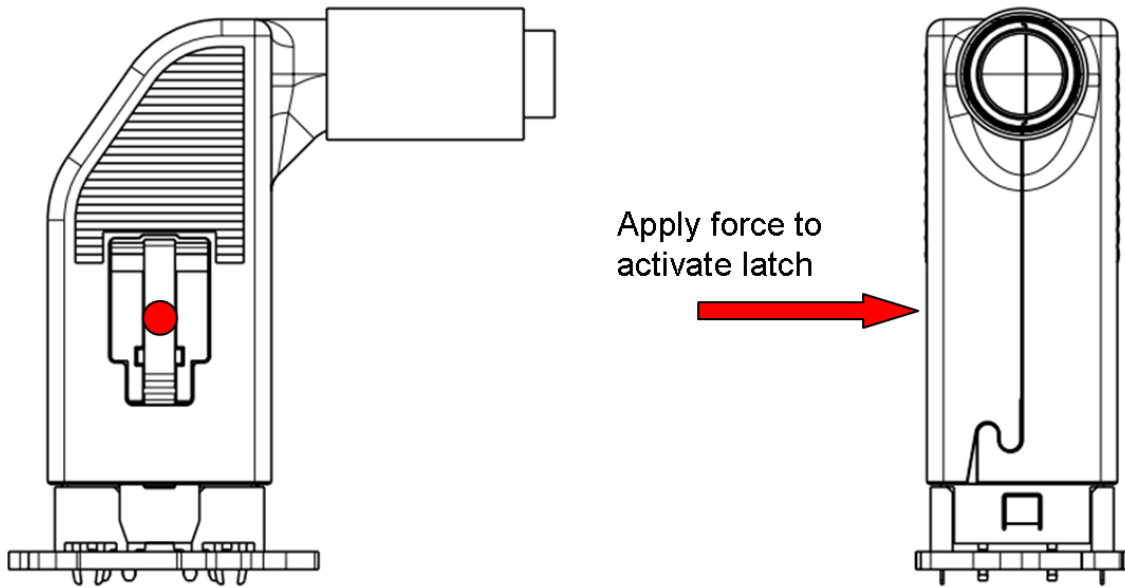
**Figure 1(termination resistance power-contacts)**



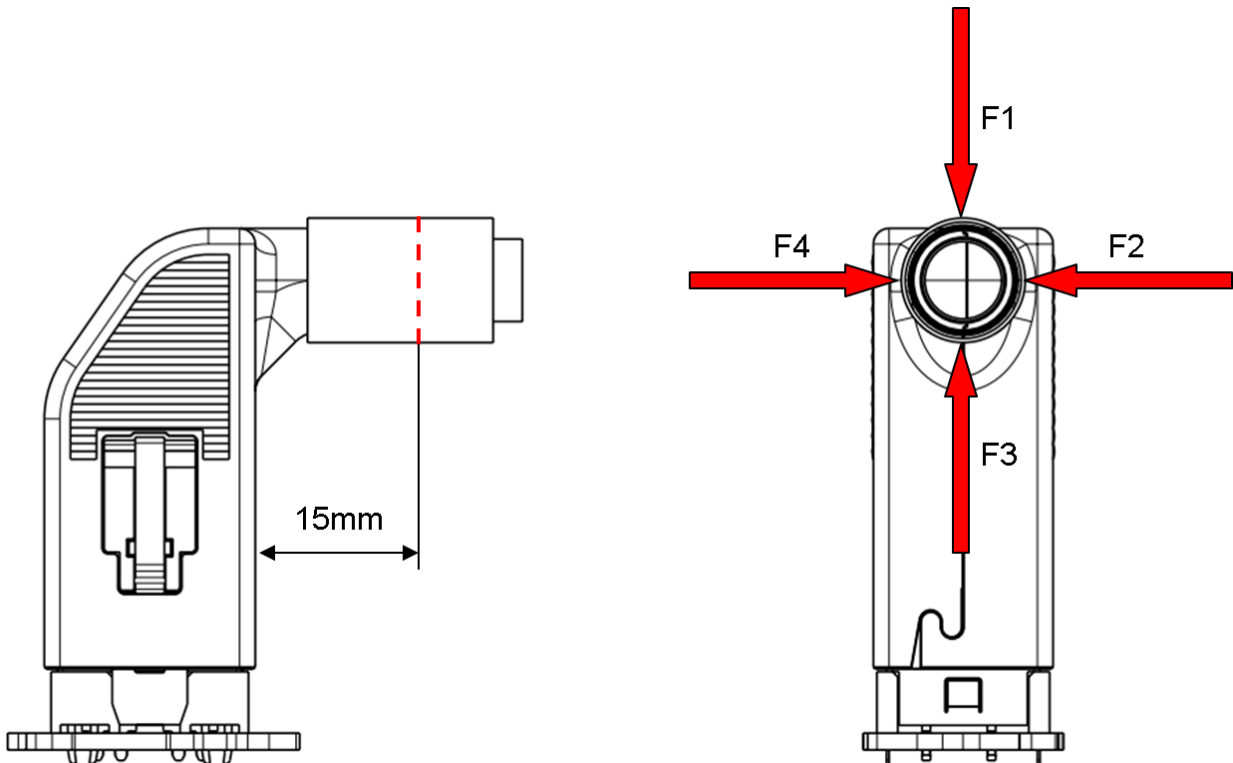
**Figure 2 (termination resistance shielding)**



**Figure 3 (shield contact spring force)**

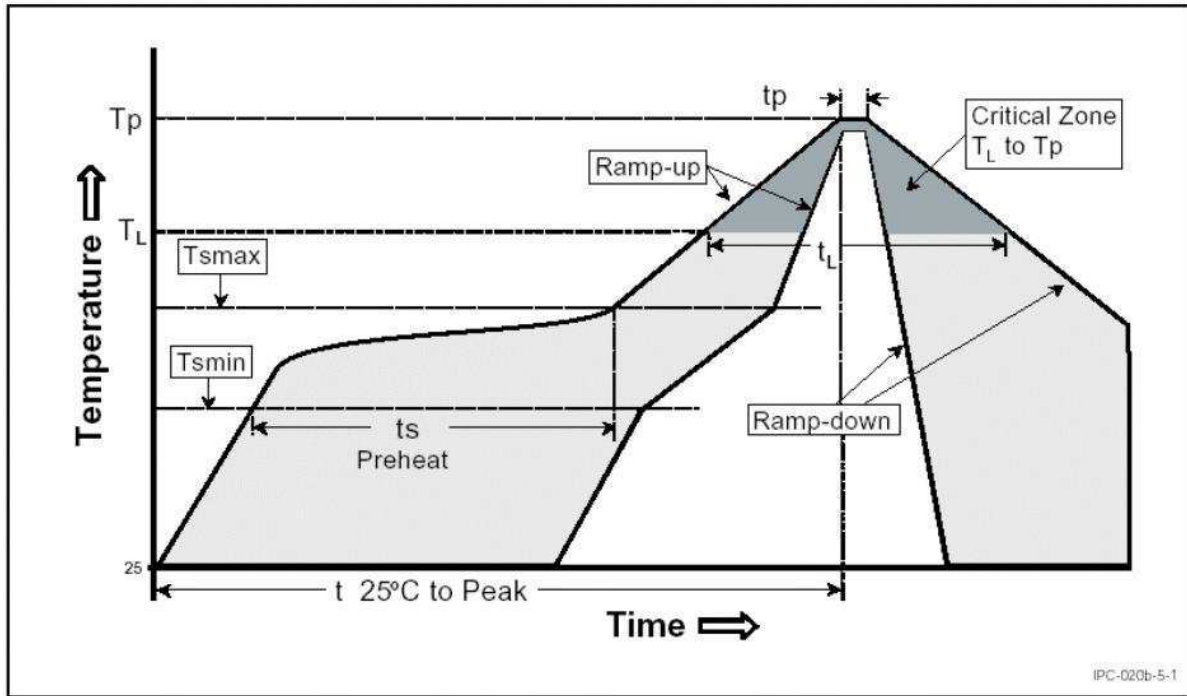


**Figure 4 (latch activation force)**



**Figure 5 (side-loads)**





Profile feature	Pb-Free Assembly Small Body
Average ramp-up rate ( $T_L$ to $T_P$ )	3°C /second max.
Preheat <ul style="list-style-type: none"> <li>- Temperature Min (<math>T_{Smin}</math>)</li> <li>- Temperature Max (<math>T_{Smax}</math>)</li> <li>- Time (min to max) (<math>t_s</math>)</li> </ul>	150°C 200°C 60-180 seconds
$T_{Smax}$ to $T_L$ <ul style="list-style-type: none"> <li>- Ramp-up Rate</li> </ul>	3°C /second max.
Preheat <ul style="list-style-type: none"> <li>- Temperature Min (<math>T_L</math>)</li> <li>- Time (<math>t_L</math>)</li> </ul>	217°C 60-150 seconds
Peak temperature ( $T_P$ )	260 +0/-5°C
Time within 5°C of actual Peak Temperature ( $t_p$ )	20-40 seconds
Ramp-down Rate	6°C /second max.
Time 25°C to Peak Temperature	8 minutes max.

**Figure 6 (soldering profile)**

3.5. Product Qualification and Requalification Test Sequence

TEST	TEST-GROUP(a)				
	1	2	3	4	5
	Test-sequence(b)				
Examination of product	1,11,13,15,17,19,22	1,15	1,11	1,16	1,4
Termination resistance power contacts	3,6,8,20	4,7,11	2,5,9	2,7,12	
Termination resistance Shielding contacts(for shielded part only)	4,9,21	5,8,12	3,6,10	3,8,13	
Insulation Resistance					
Voltage proof					
Temperature rise	5				
Electrical load and temperature	7				
Shield contact spring force(for shielded part only)		2,9,14			
Vibration Sinusoidal			7		
Physical shock			8		
Insertion/withdrawal forces (no latch)		3,10,13			
Insertion force during wrong polarization	16				
Latch activation force(for shielded part only)	2				
Mechanical operation		6			
Contact retention force (cable connector)	18				
Side-load (4 directions individually) (for shielded part only)	10				
Locking latch strength	12				
Mounting force board connector					2
Cable Pull Out Crimp Force Ferrule	14				
Rapid change of temperature			4		
Climatic sequence				6	
Damp/heat steady state				11	
Resistance to soldering heat board connector					3

Table 5

- (a) See paragraph 4.1
- (b) Numbers indicate sequence in which tests are performed.

#### 4. QUALITY ASSURANCE PROVISIONS

##### 4.1. Qualification testing

###### Sample Selection

Samples shall be prepared in accordance with applicable instructions and shall be selected at random from current production.

Unless details to perform test require otherwise, plugs shall be terminated on cables according to Applicable instructions and requirements specified in appropriate Application Specification and Instruction Sheet.

Unless otherwise specified all test groups shall consist of a minimum of five connectors of applicable type. Qualification inspection shall be verified by testing samples

##### 4.2. Requalification testing

If changes significantly affecting form, fit or function are made to product or manufacturing process, product assurance shall coordinate requalification testing, consisting of all or part of original testing sequence as determined by product, quality and reliability engineering.

##### 4.3. Acceptance

Acceptance is based on verification that product meets requirements of Para 3.4. Failures attributed to Equipment, test set-up, test sub-components or operator deficiencies shall not disqualify the product. When product failure occurs, corrective action shall be taken and samples resubmitted for qualification. Testing to confirm corrective action is required before re-submittal.

##### 4.4. Quality conformance inspection

Applicable TE quality inspection plan will specify sampling acceptable quality level to be used. Dimensional and functional requirements shall be in accordance with applicable product drawing and this specification