

Z-Pack Slim UHD Common Speed Connector System

The product described in this document has not been fully tested to ensure conformance to the requirements outlined herein. Tyco Electronics makes no representation on warranty, express or implied, that the product will comply with these requirements. Further, Tyco Electronics reserves the right to change these requirements based on the results of additional testing and evaluation. Contact Tyco Electronics Engineering for further information, if necessary.

1 SCOPE

1.1 Content

This specification covers performance, test and quality requirements for the Tyco Electronics* Z-Pack Slim UHD Common Speed Connector System. This connector system interconnects two printed circuit boards. Both receptacle and pin connectors are connected to the printed circuit board with plated thru-hole compliant press-fit leads.

1.2 Qualification

When tests are performed on subject product, procedures specified in this specification shall be used. All inspections shall be performed using applicable inspection plan and product drawing.

2 APPLICABLE DOCUMENTS

The following documents form a part of this specification to the extent specified herein. Unless otherwise specified, the latest edition of the document applies. In the event of conflict between the requirements in this specification and the product drawing, the product drawing shall take precedence. In the event of conflict between requirements of this specification and the referenced documents, this specification shall take precedence.

2.1 Tyco Electronics Documents

114-19112	Application Specification
501-19XXX	Qualification Test Report (Z-Pack Slim UHD Common Speed Connector System)
501-19XXX	Qualification Test Report (Common Speed electrical properties)

2.2 Tyco Electronics Drawing

C-2042088	Male Connector Straight
C-1982738	Female Connector Right Angle
C-2042162	Male Connector Right Angle

2.3 Other Documents

IEC 60512	Basic testing procedures and measuring methods for electromechanical components for electronic equipment.
IEC 60068	Basic environmental testing procedures.
GR-1217-Core	Telcordia uncontrolled environments.

DR. R.Annokkee

DATE 6 Dec 2007

APVD.

DATE xx Xxx xx

EC:

3 REQUIREMENTS

3.1 Design and Construction

Products shall be of design, construction and physical dimensions as specified on the applicable product drawing.

3.2 Materials and Finish

Materials used in the construction of this product shall be as specified on the applicable product drawing.

3.3 Ratings

- | | | |
|----|--------------|------------------------------|
| A. | Voltage: | 250 V AC (peak value) |
| B. | Current: | 0.5 A/contact (fully loaded) |
| C. | Temperature: | -55 °C to 105 °C |
| D. | Durability: | 250 cycles |

3.4 Performance and Test Description

The product is designed to meet electrical, mechanical and environmental performance specified in this paragraph as tested per test sequence specified in Paragraph 3.6.

Unless otherwise specified, all tests are performed at ambient environmental conditions per IEC specification 60068-1 clause 5.3 and are performed with connectors in fully mated condition.

V I S U A L			
Para	Test Description	Performance Requirement or Severity	Procedures
3.4.1	Visual examination	Meets applicable requirements specified on product drawing, customer drawing, and application specification.	Visual, dimensional and functional per applicable inspection-plan. In accordance with IEC 60512-1-1.
E L E C T R I C A L			
Para	Test Description	Performance Requirement or Severity	Procedures
3.4.2	Contact resistance	Max. open voltage 20 mV. Max. current 100 mA DC. Requirement: Initial 80 mΩ max. Individual increase 10 mΩ max. and 5 mΩ max. average after test.	In accordance with IEC 60512-2-1. See paragraph 3.5.1.
3.4.3	Insulation resistance	Test voltage: 100 VDC. Duration: 1 minute. Measure between adjacent contacts. Requirement: 10.000 MΩ min.	In accordance with IEC 512-3-1.
3.4.4	Voltage proof	Test voltage: 500 VAC. Duration: 1 minute. Test between adjacent contacts. Requirement: No break-down or flash-over.	In accordance with IEC 60512-2-4a.
3.4.5	Current load cyclic	Test current 0.625 A (125% of rated current). 1 cycle is 45 min. "on" & 15 min. "off". Number of cycles: 20. Test shall be conducted with all contacts charged simultaneously.	In accordance with IEC 60512-9-5.
3.4.6	Temperature rise	Test shall be conducted with all contacts charged simultaneously. Requirement: ΔT 30 °C max. at 0.625 A (125% of rated current).	In accordance with IEC 60512-5-1.
3.4.7	Differential connector impedance	Time Domain (TDR) measurement. Connector impedance: footprint impedance excluded. Risettime of incident pulse at connector: 100 ps (10%-90%). Connector S:G Ratio: 1:1 (see paragraph 3.5.3). Requirement: 100 Ω ± 10%.	In accordance with EIA-364-108 / IEC 60512-25-7.

3.4.8	Differential connector insertion loss	Frequency Domain (FDT) Mixed-Mode S-parameter measurement. Connector S:G Ratio: 1:1 (see paragraph 3.5.3). Requirement: -1 dB min. up to 1 GHz -2 dB min. up to 2 GHz -3 dB min. up to 3 GHz.	In accordance with EIA-364-108 / IEC 60512-25-2.
3.4.9	Differential connector near-end and far-end noise	Maximum peak differential pair-to-pair noise (single aggressor). Risetime of incident pulse at connector: 100 ps (10%-90%). All other signal lines terminated to 50 Ω. Connector S:G Ratio: 1:1 (see paragraph 3.5.3). Requirement: 1% max.	In accordance with EIA-364-90 / IEC 60512-25-1.
3.4.10	Connector delay	Time Domain (TDT) measurement. Time delay measured between 10% amplitude levels of output and incident pulse. Connector S:G Ratio: 1:1 (see paragraph 3.5.3). Requirement: 220 ps max.	In accordance with IEC 60512-25-4.
3.4.11	Connector pair to pair skew	Time Domain (TDT) measurement. Time delay measured between 10% amplitude levels of output and incident pulse. Connector S:G Ratio: 1:1 (see paragraph 3.5.3). Requirement: 80 ps max.	In accordance with IEC 60512-25-4.
3.4.12	Connector inner pair skew	Time Domain (TDT) measurement. Skew measured between 10% amplitude levels of complementary output pulses. Connector S:G Ratio: 1:1 (see paragraph 3.5.3). Requirement: 12 ps max.	In accordance with IEC 60512-25-4.

M E C H A N I C A L			
Para	Test Description	Performance Requirement or Severity	Procedures
3.4.13	Mating force	Connectors aligned. Speed: 10 mm/s. Requirement: 0.45 N/contact max X nr of contacts	In accordance with IEC 60512-7-13b.
3.4.14	Unmating force	Connectors aligned. Speed: 10 mm/s. Requirement: 0.1 N/contact min X nr of contacts.	In accordance with IEC 60512-7-13b.
3.4.15	Mechanical operation	Mate 250 cycles. Connectors aligned. Speed: 2 mm/s. Rate: 10 cycles/minute. Requirement: No functional damage. Contact resistance. Insertion force.	In accordance with IEC 60512-9-1.
3.4.16	Vibration sinusoidal	10-500 Hz sweeping, 1 octave/minute. Amplitude 0.35 mm max., acceleration 50 m/s ² max. 15 minutes in each of 3 mutual perpendicular axes. Printed circuit boards mutually fixated. Requirement: No physical damage. Contact discontinuity 1 μs max. Contact resistance.	In accordance with IEC 60512-6-4. See paragraph 3.5.2.
3.4.17	Shock test	Pulse shape: Half sine. Peak acceleration: 490 m/s ² . Duration of pulse: 11 ms. Apply 3 shocks in each direction of 3 mutual perpendicular axes (18 shocks). Requirement: No physical damage. Contact discontinuity 1 μs max. Contact resistance.	In accordance with IEC 60512-6-3. See paragraph 3.5.2.
3.4.18	Minute disturbance	Withdraw and insert a distance of approximately 0.1 mm. Requirement: Contact discontinuity 1 μs max.	In accordance with IEC 60512-2-2e.
3.4.19	Retention force	Force to unseat connector 0.25 mm from board. Speed: 0.5 mm/s. Requirement: 15 N/column average min. (male) 30 N/column average min. (female).	In accordance with IEC 60512-5-8b (male) or IEC 60512-5-8a (female). See paragraph 3.5.4.

ENVIRONMENTAL			
Para	Test Description	Performance Requirement or Severity	Procedures
3.4.20	Cold	Temperature -55 °C. Duration 96 hours. Recovery: 2 hours at ambient atmosphere. Requirements: No physical damage. Contact resistance.	In accordance with IEC 68-2-1-Ab.
3.4.21	Dry heat	Temperature 125 °C. Duration 96 hours. Recovery: 2 hours at ambient atmosphere. Requirements: No physical damage. Contact resistance.	In accordance with IEC 68-2-2-Bb.
3.4.22	Rapid change of temperature	-55 °C / +125 °C, variation ± 5 °C/minute. 25 cycles. Requirements: No physical damage. Contact resistance.	In accordance with IEC 68-2-14-Nb.
3.4.23	Damp heat cyclic	Temperature 25-55 °C, RH 90-100% for 6 cycles of 24 hours each. Transition time: 3 hours. Recovery: 2 hours at 25 °C, RH 75%. Requirements: No physical damage. Contact resistance. Insulation resistance.	In accordance with IEC 68-2-30-Db.
3.4.24	Damp heat steady state	Temperature 40°C, RH 95% for 21 days. Requirements: No physical damage. Contact resistance. Insulation resistance.	In accordance with IEC 60512-11-3.
3.4.25	Mixed flowing gas corrosion	240 hours mated and 240 hours unmated. H ₂ S 0.1 ppm, SO ₂ 0.2 ppm. CL ₂ 0.02 ppm. NO ₂ 0.2 ppm. Temperature 30 \pm 2 °C, RH 70%. Recovery: 1 hour at ambient atmosphere. Requirements: Contact resistance	In accordance with Telcordia uncontrolled environments GR-1217-Core 9.1.3

3.5 Additional Test and Measuring Details

3.5.1 Contact resistance

Contact resistance shall be measured as indicated in figure 1.
Contact path bulk of connected parts is not included in the requirement.

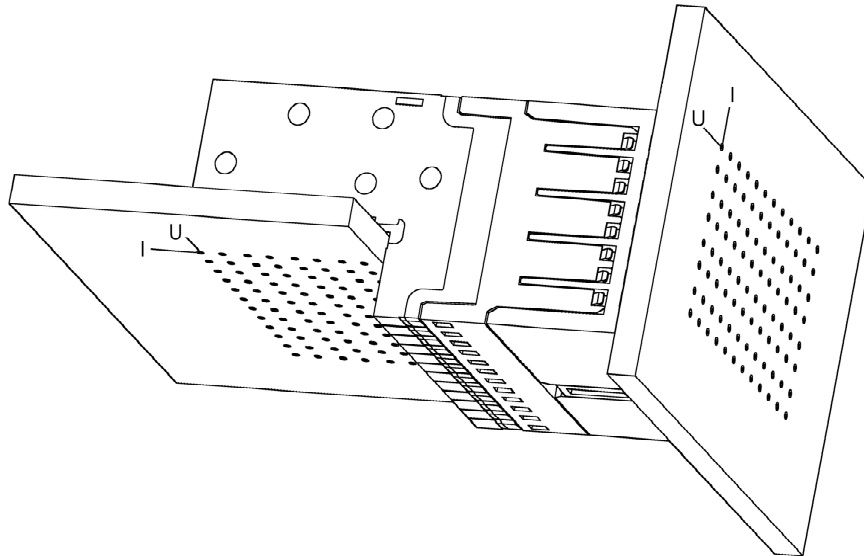

Figure 1. Contact resistance measurement.

3.5.2 Test frames

Test-frames shall provide mechanical stability of the connector in relation to its mating part and shall cover the requirements specified in the Tyco Electronics application specification.

During Vibration, an electrical circuit is checking that no electrical contact interruptions occur that exceed the requirement.

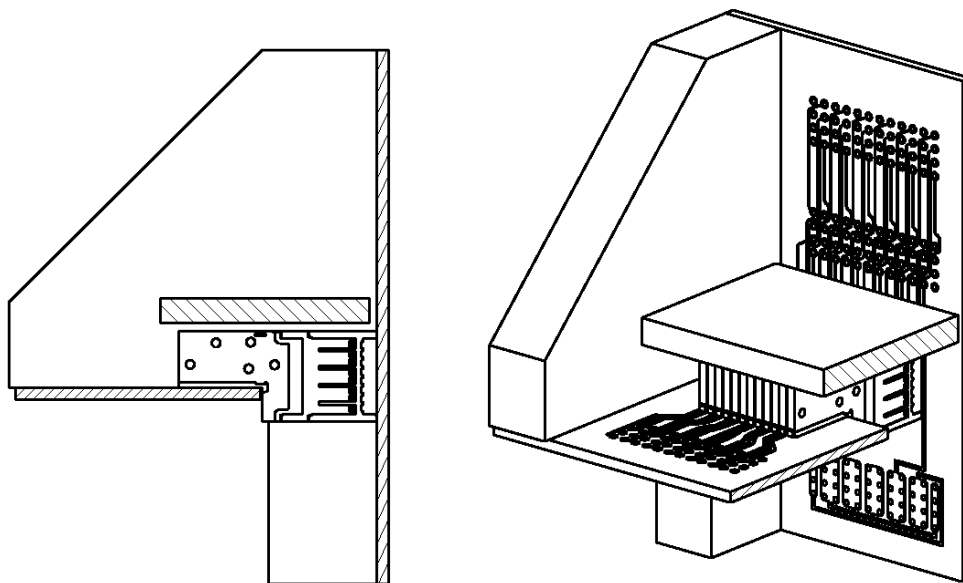

Figure 2. Vibration and Physical shock mounting feature.

3.5.3 Pin Layout

Pin layout for signal to ground ratio 1:1 as defined in figure 3.

S:G 1:1		Columns											
		1	2	3	4	5	6	7	8	9	10	11	12
Rows	h	X	A+	X	A+	X	A+	X	A+	X	A+	X	A+
	g	X	A-	X	A-	X	A-	X	A-	X	A-	X	A-
	f	A+	X	A+	X	A+	X	A+	X	A+	X	A+	X
	e	A-	X	A-	X	A-	X	A-	X	A-	X	A-	X
	d	X	A+	X	A+	X	A+	X	A+	X	A+	X	A+
	c	X	A-	X	A-	X	A-	X	A-	X	A-	X	A-
	b	A+	X	A+	X	A+	X	A+	X	A+	X	A+	X
	a	A-	X	A-	X	A-	X	A-	X	A-	X	A-	X

X	Ground Connection
A+/-	Active Differential Line

Figure 3. Pin layout.

3.5.4 Retention force

For testing the mechanical connection to the board, forces shall be applied as indicated in figure 4.

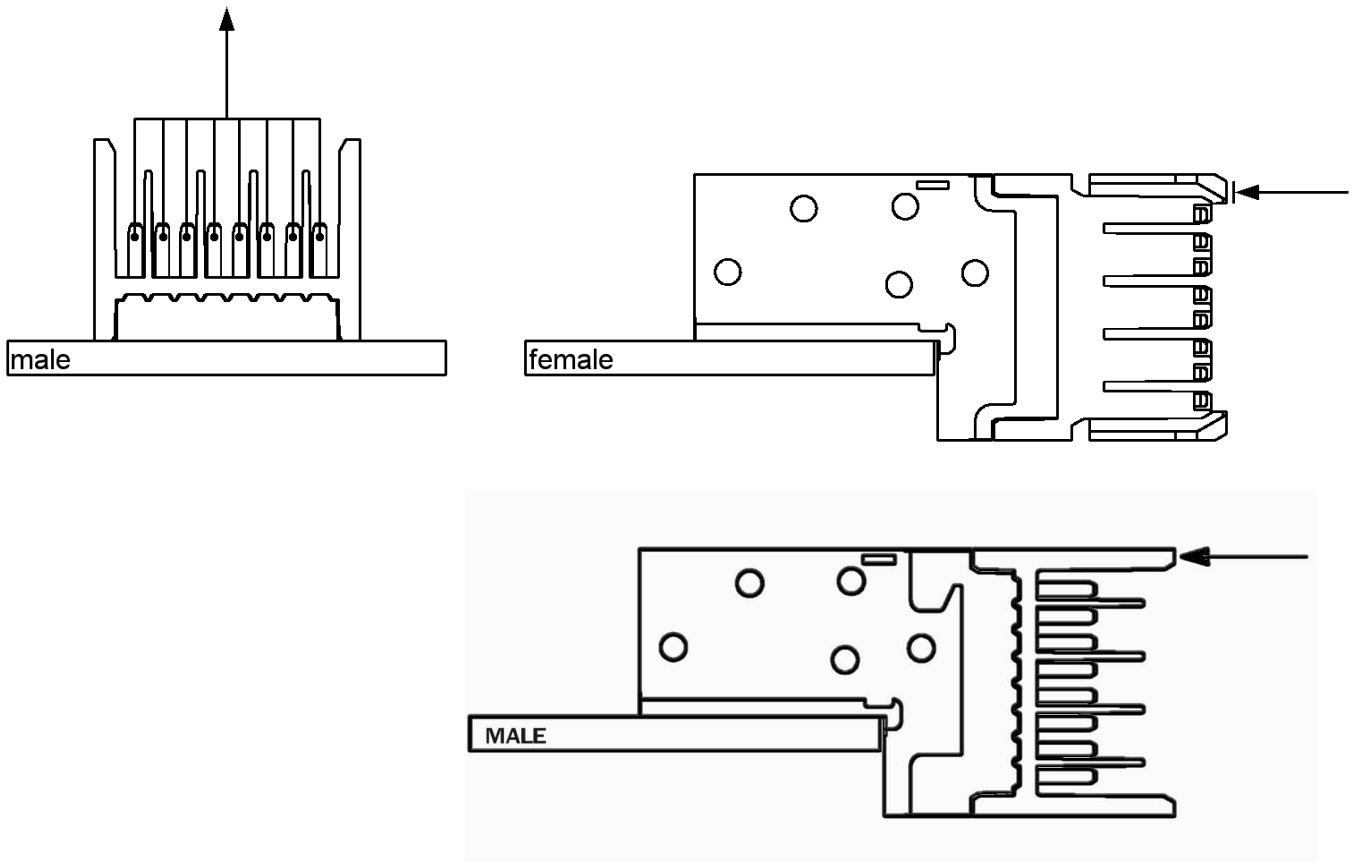

Figure 4. Retention force measurement.

3.6 Product Qualification and Regualification Test Sequence

Test or examination	TEST - GROUP (a)				
	1	2	3	4	5
	TEST - SEQUENCE (b)				
Examination of product	1,15	1,15	1,13	1,11	1
Contact resistance	2,6,9,12,14	2,4,6,8,10,12	2,4,6,8,10	2,4,6,8,10	
Insulation resistance		13	11		
Voltage proof		14	12		
Current load cyclic			5		
Temperature rise			3		
Differential connector impedance					2
Differential connector insertion loss					3
Differential connector near-end and far-end noise					4
Connector delay					5
Connector pair to pair skew					6
Connector inner pair skew					7
Insertion force	3,7				
Withdrawal force	4,8				
Durability	5	3		3(c),9(c)	
Vibration sinusoidal	10				
Physical shock	11				
Minute disturbance	13			7	
Retention force			7		
Damp heat steady state			9		
Cold		9			
Dry heat		7			
Rapid change of temperature		5			
Damp/heat cyclic		11			
Mixed gas				5	

(a) See paragraph 4.1.A.

(b) Numbers indicate sequence in which tests are performed.

(c) Perform 50% of the durability cycles before, and 50% of the durability cycles after the mixed gas testing.

Sample description	Number of described samples in test groups				
	1	2	3	4	5
Connector mounted on PC-board	5	5	5	5	5

4 QUALITY ASSURANCE PROVISIONS

4.1 Qualification testing

A. Sample selection

Samples shall be prepared in accordance with applicable instructions and shall be selected at random from current production.

Unless otherwise specified, all test-groups shall consist of a minimum of 5 connectors of which all contacts shall be tested.

B. Test sequence

Qualification inspection shall be verified by testing samples as specified in paragraph 3.6.

4.2 Regualification testing

If changes significantly affecting form, fit or function are made to product or manufacturing process, product assurance shall coordinate requalification testing, consisting of all or part of original testing sequence as determined by product, quality and reliability engineering.

4.3 Acceptance

Acceptance is based upon verification that product meets requirements of paragraph 3.4. Failures attributed to equipment, test set-up, applied customer components or operator deficiencies shall not disqualify the product. When product failure occurs, corrective action shall be taken and samples resubmitted for requalification. Testing to confirm corrective action is required before resubmittal.

4.4 Quality conformance inspection

Applicable Tyco Electronics quality inspection plan will specify sampling acceptable quality level to be used. Dimensional and functional requirements shall be in accordance with applicable product drawing and this specification.