

NUMBER

108-19041

AMP SECURITY CLASSIFICATION

PRODUCT SPECIFICATION FOR AMP-EDGE
LOW PROFILE CONNECTORS

(Standard programme .100, .156)

1. Scope :

This document specifies general requirements for multi-contact connector assemblies for use with printed wiring boards. The assembly provides a connection between conventional- and printed-wiring or serves as board to board connector. They are designed to accept printed wiring boards, nominal thickness 1,6 mm (1,45 min., 1,83 max.)

2. Applicable Documents :

2.1. The following documents form a part of this specification to the extent indicated here in :

- QQ-B-750 Phosphor bronze
- IEC Pub. 512 Test methods
- IEC Pub. 68 Test methods
- QQ-N-290 Nickel electro-deposited
- MIL-G-45204 Gold electro-deposited

3. Performance Ratings :

3.1. -Current carrying capacity : 3 Amperes maximum per contact at 20°C Ambient Temperature.

- Temperature range -55°C to +125°C.

THIS INFORMATION IS CONFIDENTIAL AND IS DISCLOSED TO YOU ON CONDITION THAT NO FURTHER DISCLOSURE IS MADE BY YOU TO OTHER THAN AMP PERSONNEL WITHOUT WRITTEN AUTHORIZATION FROM AMP-HOLLAND B.V.

-	-	-	-	LOC.	SIZE	AMP	AMP-HOLLAND B.V. s-Hertogenbosch, The Netherlands.	
B	REDRAWN	C.F.S.	12-07-89	H	A4			
A	CHANGED	G.V.A	26-11-82	DR.	DATE	NAME PRODUCT SPECIFICATION FOR AMP-EDGE LOW PROFILE CONNECTORS.		
O	RELEASED	G.V.A	17-05-82	J.V.D. HEIJDEN	12-07-89			
REV. LTTR.		DR.	DATE	CHK.	DATE			
REVISION RECORD				APP.	DATE	DWG. No.	SHEET	REV.
				L.V.SOEST	-	108-19041	1 OF 9	B

NUMBER
108-19041

AMP SECURITY
CLASSIFICATION

3.2 Test requirements and procedures summary.

Testdescription	Requirements	Procedure
Examination of the product	Meets requirements of drawing	Dimensional and visual

ELECTRIAL

Insulation resistance	1000 M Ω min.	Test voltage 500 volt. The resistance shall be measured between adjacent and opposite contacts and between mounting hardware and any contact. I.E.C. Pub. 512 test no. 3a method B.
High Voltage proof	<u>Pitch Up eff</u> .100 650 .156 1800	The test voltage shall be gradually increased at a rate of approx. 500 Volt per second until the voltage is reached. I.E.C. Pub. 512 test no. 4A.
Contact resistance	12 m Ω max.	Measuring points according figure 2. IEC Pub. 512 test no. 2A

MECHANICAL

Vibration	No discontinuity greater than 1 μ sec.	Method IEC 68-2-6 Procedure B4 10-500 Hz 0,35 mm - 5 g 20 contacts monitored at 2,5 V max 100 mA dc
Physical shock	No discontinuity greater than 1 μ sec. No physical damage	Half sine wave form, 30 g, 11 ms, 6 mutually perpendicular axes IEC Pub. 512 test no. 6C

AMP

AMP-HOLLAND B.V.
s-Hertogenbosch,
The Netherlands.

NAME PRODUCT SPECIFICATION
FOR AMP-EDGE LOW
PROFILE CONNECTORS.

DWG. No.

108-19041

SHEET

2 OF 9

REV.

B

THIS INFORMATION IS CONFIDENTIAL AND IS DISCLOSED TO YOU ON
CONDITION THAT NO FURTHER DISCLOSURE IS MADE BY YOU TO OTHER
THAN AMP PERSONNEL WITHOUT WRITTEN AUTHORIZATION FROM AMP-HOLLAND B.V.

NUMBER

108-19041

AMP SECURITY CLASSIFICATION

THIS INFORMATION IS CONFIDENTIAL AND DISCLOSED TO YOU ON CONDITION THAT NO FURTHER DISCLOSURE IS MADE BY YOU TO OTHER THAN AMP PERSONNEL WITHOUT WRITTEN AUTHORIZATION FROM AMP-HOLLAND B.V.

Testdescription	Requirements	Procedure						
Individual engaging and separating force	3,7 N max. engaging force 0,25 N min. separating force	Engaging force, maximum thickness gauge .072 inch (1,83 mm) Separating force, minimum thickness gauge .057 inch (1,45 mm) The dimensions of the gauge are shown in figure 3.						
Insertion and withdrawal force	Max. 4 N times numbers of positions Min. 0,25 N times number of positions	Ins. force measured with max. gauge. Withdrawal force measured with min. gauge. The steelgauge shall be conform the drawing of figure 4.						
Durability	No mechanical damage or deterioration of contacts and housing	the rate of insertion and extraction cycling shall not exceed 15 operations/min. Speed 10 mm/s. <table border="0"> <tr> <td><u>plating</u></td> <td><u>Cycles</u></td> </tr> <tr> <td>0,4 μM gold</td> <td>20</td> </tr> <tr> <td>0,8 μM gold</td> <td>50</td> </tr> </table> The steel gauge shall be conform the drawing of figure 4.	<u>plating</u>	<u>Cycles</u>	0,4 μM gold	20	0,8 μM gold	50
<u>plating</u>	<u>Cycles</u>							
0,4 μM gold	20							
0,8 μM gold	50							
Contact force	Minimum 100 g per contact	The force of a contact must be measured at a deflection of a printed circuit board of 1,45 mm (.057").						
Rapid change of temperature	No evidence of physical damage	5 cycles, 30 min., Specimen mated : -55°C to 125°C Recovery time : 1h IEC Pub. 512 test no.11 D Method IEC 68-8-14 TEST Na -55°C - +125°C t1 = 30 min. Connector in mated condition.						

AMP

AMP-HOLLAND B.V.
s-Hertogenbosch,
The Netherlands.

NAME PRODUCT SPECIFICATION
FOR AMP-EDGE LOW
PROFILE CONNECTORS.

DWG. No.

108-19041

SHEET

3 of 9

REV.

B

THIS INFORMATION IS CONFIDENTIAL AND IS DISCLOSED TO YOU ON CONDITION THAT NO FURTHER DISCLOSURE IS MADE BY YOU TO OTHER THAN AMP PERSONNEL WITHOUT WRITTEN AUTHORIZATION FROM AMP-HOLLAND B.V.

AMP SECURITY CLASSIFICATION

NUMBER

108-19041

Testdescription	Requirements	Procedure
Humidity	Insulation resistance 10 ⁸ ohm min.	Humidity test according I.E.C. Pub. 512 test 11 C. (90-95% R.H. at 40°C for 21 days).
Corrosion,	Contact Resistance 12 mA max.	Connectors mated with test boards 24 hr at 25°C relative humidity 75%, SO ₂ concentration 10 p.p.m.

4. Test Conditions :

Unless otherwise stated here in, tests and examinations required by this specification shall be made under any combination of conditions within the range below :

Temperature : 15°C to 35°C
 Relative humidity : 45 to 75 percent
 Barometric pressure : 860 - 1060 mbar
 (650 to 800 mm Hg)

4.1. Test Samples :

- 4.1.1. Printed wiring test boards -Printed wiring test boards used, shall be in accordance with fig. 1.
- 4.1.2. Connector receptacles -The connector receptacles must be conform the applicable product drawings.
- 4.1.3. Total steel gauges -The total steel gauges shall be conform the drawing of figure 4.
- 4.1.4. Individual steel gauge -The individual steel gauge shall be conform the drawing of figure 3.

AMP		AMP-HOLLAND B.V. s-Hertogenbosch, The Netherlands.	
NAME PRODUCT SPECIFICATION FOR AMP-EDGE LOW PROFILE CONNECTORS.			
DWG. No.		SHEET	REV.
108-19041		4 OF 9	B

NUMBER
108-19041

AMP SECURITY
CLASSIFICATION

THIS INFORMATION IS CONFIDENTIAL AND IS DISCLOSED TO YOU ON
CONDITION THAT NO FURTHER DISCLOSURE IS MADE BY YOU TO OTHER
THAN AMP PERSONNEL WITHOUT WRITTEN AUTHORIZATION FROM AMP-HOLLAND B.V.

Test or examination	I	II	III	IV
Examination of product	X	X	X	X
Contact resistance	X	X	X	X
Insulation resistance	X	X	X	X
High voltage proof	X	X	X	X
Contact engaging and separating force	X	X	X	X
Insertion and withdrawal forces		X		
Durability		X		
Insertion and withdrawal forces		X		
Contact resistance		X		
Corrosion		X		
Contact resistance		X		
Temperature cycling			X	
Vibration			X	
Shock			X	
Contact resistance			X	
Insertion and withdrawal forces			X	
Humidity				X
Contact resistance				X
Insulation resistance				X
High voltage proof				X
Examination of product	X	X	X	X

AMP		AMP-HOLLAND B.V. s-Hertogenbosch, The Netherlands.	
NAME PRODUCT SPECIFICATION FOR AMP-EDGE LOW PROFILE CONNECTORS.			
DWG. No.		SHEET	REV.
108-19041		5 OF 9	B

NUMBER
108-19041

AMP SECURITY
CLASSIFICATION

THIS INFORMATION IS CONFIDENTIAL AND IS DISCLOSED TO YOU ON
CONDITION THAT NO FURTHER DISCLOSURE IS MADE BY YOU TO OTHER
THAN AMP PERSONNEL WITHOUT WRITTEN AUTHORIZATION FROM AMP-HOLLAND B.V.

FIGURE 1.

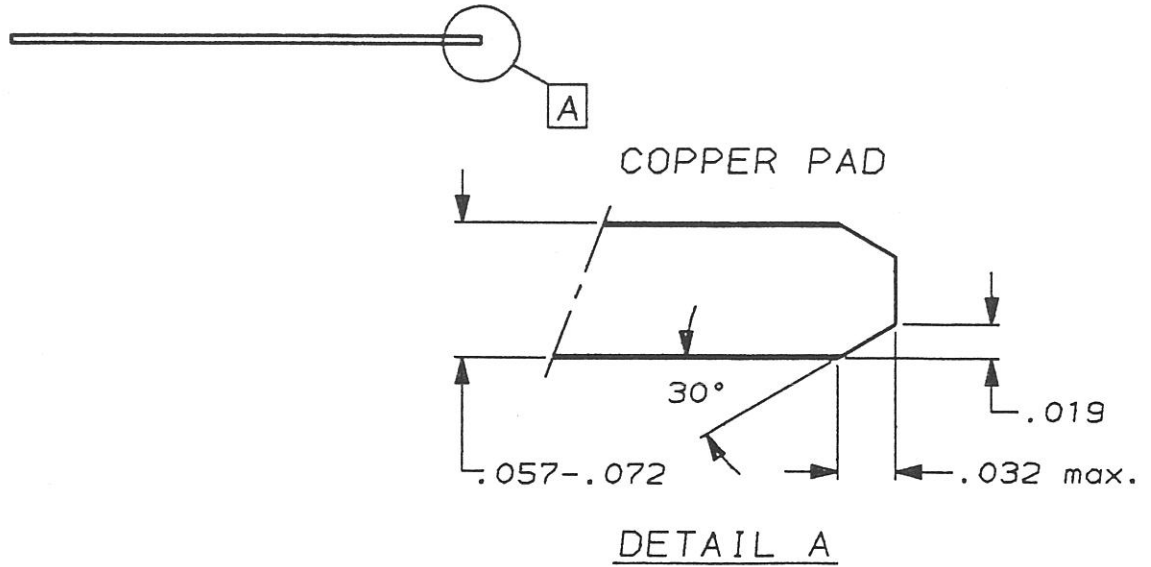
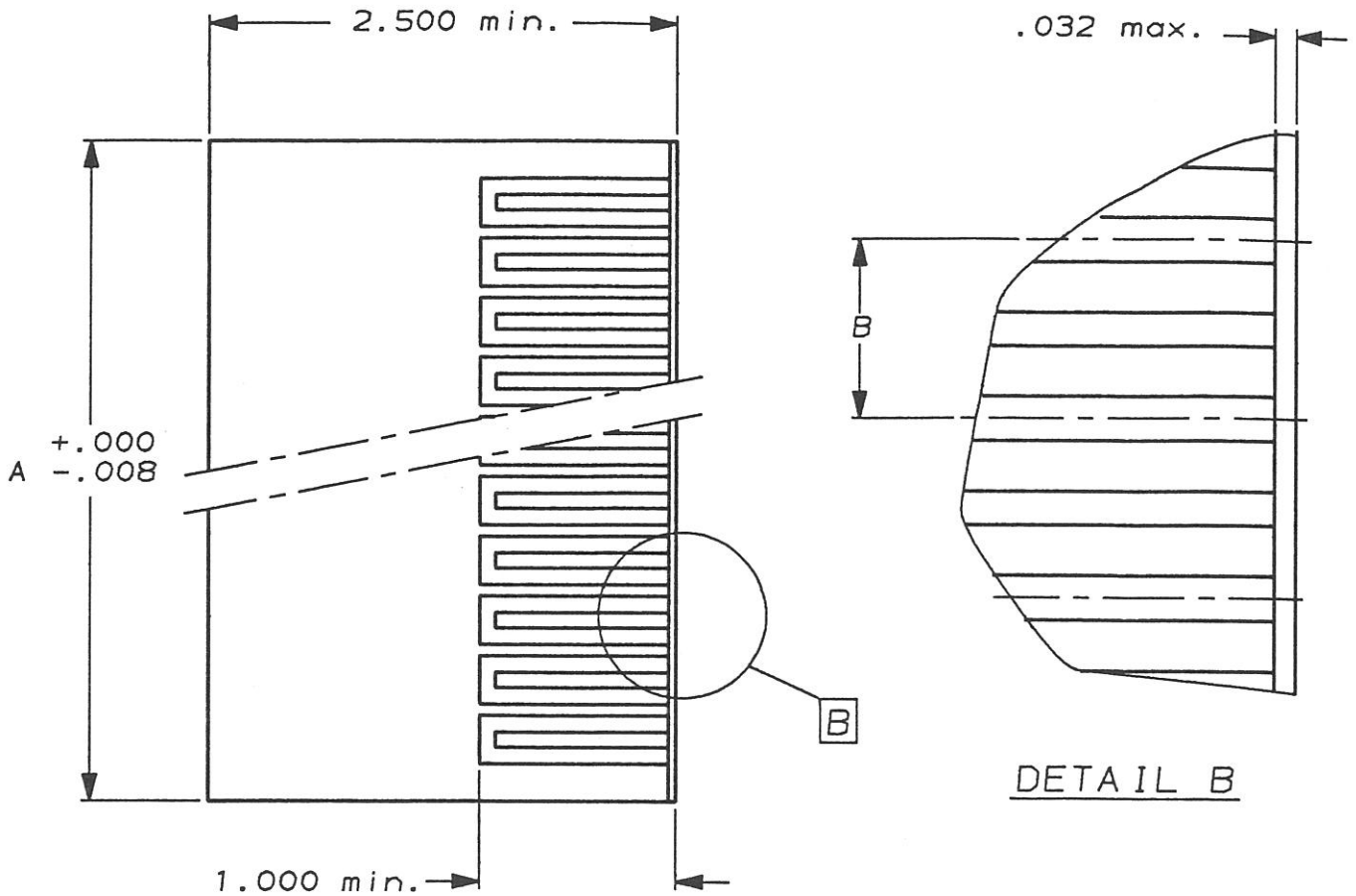

Note : 1. Tolerances $\pm .005$ unless shown otherwise.

2. A : equal to min. cardslot length of the connector

B : equal to pitch of connector

AMP		AMP-HOLLAND B.V. s-Hertogenbosch, The Netherlands.	
NAME PRODUCT SPECIFICATION FOR AMP-EDGE LOW PROFILE CONNECTORS.			
DWG. No.	SHEET	REV.	
108-19041	6 OF 9	B	

FIGURE 2

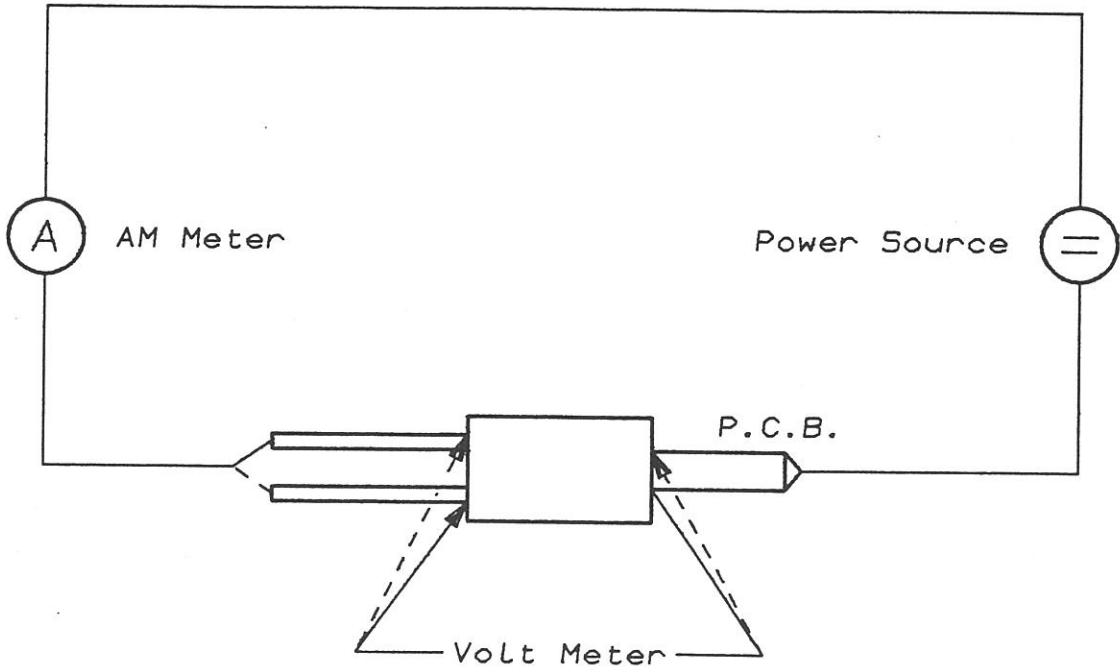

Note 1: P.C.B. according to fig. 1

THIS INFORMATION IS CONFIDENTIAL AND NOT TO BE DISCLOSED TO YOU ON ANY OTHER CONDITION THAN AMP PERSONNEL WITHOUT WRITTEN AUTHORIZATION FROM AMP-HOLLAND B.V.

AMP		AMP-HOLLAND B.V. s-Hertogenbosch, The Netherlands.	
NAME PRODUCT SPECIFICATION FOR AMP-EDGE LOW PROFILE CONNECTORS.			
DWG. No.		SHEET	REV.
108-19041		7 of 9	B

NUMBER
108-19041

AMP SECURITY
CLASSIFICATION

FIGURE 3

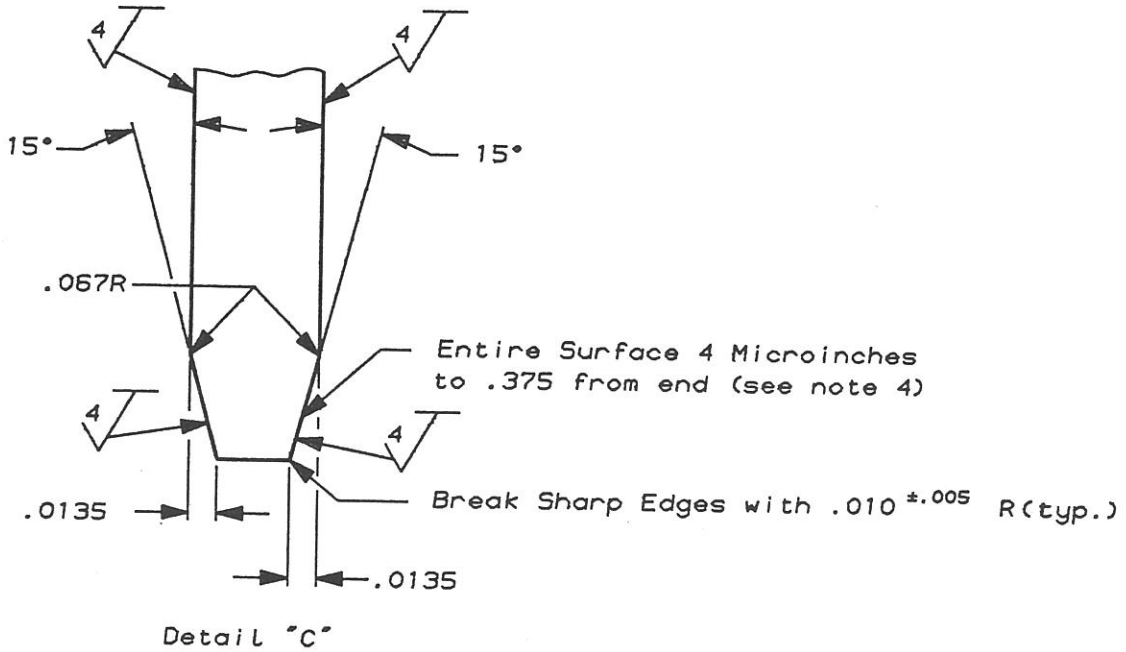
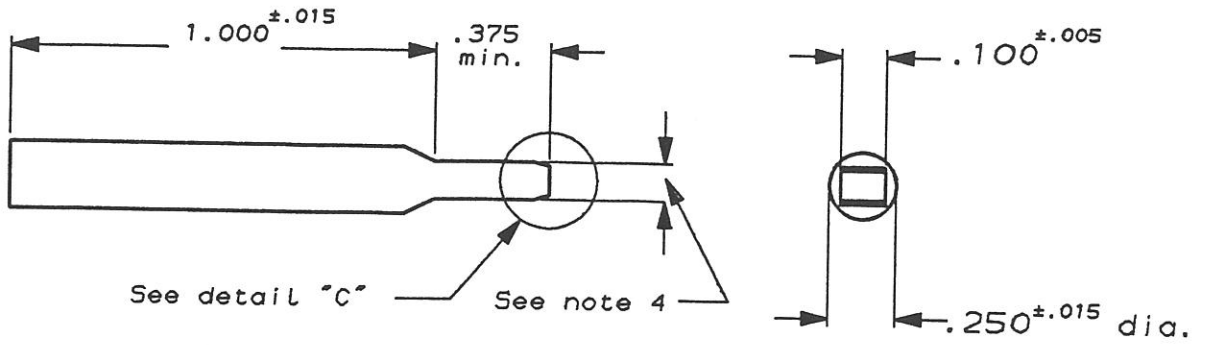

NOTES :

1. Only the Working Surface designated 4 shall be finished.
2. Tolerances: ±.005 unless shown otherwise.
3. Material: Hardened Tool Steel Rockwell "C" 50-55.
4. Tolerance: ±.0001.

THIS INFORMATION IS CONFIDENTIAL AND DISCLOSED TO YOU ON CONDITION THAT NO FURTHER DISCLOSURE IS MADE BY YOU TO OTHER THAN AMP PERSONNEL WITHOUT WRITTEN AUTHORIZATION FROM AMP-HOLLAND B.V.

AMP		AMP-HOLLAND B.V. s-Hertogenbosch, The Netherlands.	
NAME PRODUCT SPECIFICATION FOR AMP-EDGE LOW PROFILE CONNECTORS.			
DWG. No.		SHEET	REV.
108-19041		8 OF 9	B

