

---

**NETCONNECT\*, CHAMP\* System 5 Modular Jack Patch Panel**

---

**1. SCOPE**

## 1.1. Content

This specification covers performance, tests and quality requirements for NETCONNECT\* CHAMP\* System 5 modular jack patch panels used to connect building wiring for data and voice networking systems.

## 1.2. Qualification

When tests are performed on the subject product line, procedures specified in Figure 1 shall be used. All inspections shall be performed using the applicable inspection plan and product drawing.

## 1.3. Qualification Test Results

Successful qualification testing on the subject product line was completed on 27Feb98. The test file number for this testing is CTL 1962-000-009. This documentation is on file at and available from the Americas Regional Laboratory.

**2. APPLICABLE DOCUMENTS**

The following documents form a part of this specification to the extent specified herein. Unless otherwise specified, the latest edition of the document applies. In the event of conflict between the requirements of this specification and the product drawing, the product drawing shall take precedence. In the event of conflict between the requirements of this specification and the referenced documents, this specification shall take precedence.

## 2.1. TE Connectivity (TE) Documents

- 109-1: General Requirements for Test Specifications
- 109 Series: Test Specifications as indicated in Figure 1
- 108-1163: Product Specification (Modular Plugs, Thru-Hole & Surface Mount, Data & Telephone, PCB Mounted)
- 108-1576: Product Specification (Patch Panel, Modular Jack To 110Connect Block)
- 108-1576-1: Product Specification (Patch Panel, Modular Jack To RJ21 CHAMP Connector)
- 108-6019: Product Specification (Connector, CHAMP, ACTION PIN\*)
- 408-3358: Instruction Sheet
- 501-379-2: Qualification Test Report

## 2.2. Commercial Specifications

EIA/TIA-568-A, Annex A: Reliability of Connecting Hardware Used For 100 Ohm UTP Cabling

**3. REQUIREMENTS**

## 3.1. Design and Construction

Product shall be of the design, construction and physical dimensions specified on the applicable product drawing.

### 3.2. Materials

Materials used in the construction of this product shall be as specified on the applicable product drawing.

### 3.3. Ratings

- Voltage: 150 vac
- Current: Signal application only
- Temperature: -40 to 70°C

### 3.4. Performance and Test Description

Product is designed to meet the electrical, mechanical and environmental performance requirements specified in Figure 1. Unless otherwise specified, all tests shall be performed at ambient environmental conditions per AMP Specification 109-1.

### 3.5. Test Requirements and Procedures Summary

Test Description	Requirement	Procedure
Examination of product.	Meets requirements of product drawing.	Visual, dimensional and functional per applicable quality inspection plan.
<b>ELECTRICAL</b>		
Dry circuit resistance.	$\Delta R$ 20 milliohms maximum increase.	TE Spec 109-6-6. Subject samples to 20 mv maximum open circuit at 100 ma maximum. See Figure 3.
Insulation resistance.	100 megohms minimum.	TE Spec 109-28-4. Test between adjacent contacts.
Near end crosstalk.	TIA/EIA-568-A, 10.4.4.2., Table 10-9. Cat 5. See Figure 4.	Test per TIA/EIA-568-A, Para 10.4.4. using test setup shown in Figure 5. Test either ports 1-6, 7-12, 13-18, or 19-24.
Attenuation.	TIA/EIA-568-A, 10.4.4.1., Table 10-8. Cat 5. See Figure 4.	Test per TIA/EIA-568-A, Para 10.4.4. using test setup shown in Figure 6. Test either ports 1-6, 7-12, 13-18, or 19-24.
Return loss.	See Figure 4.	Test per TIA/EIA-568-A, Para 10.4.4. using test setup shown in Figure 5. Test either ports 1-6, 7-12, 13-18, or 19-24.
<b>MECHANICAL</b>		
Vibration, sinusoidal.	No discontinuities of 1 microsecond or longer duration. See Note.	TE Spec 109-21-1. Subject mated samples to 10-55-10 Hz traversed in 5 minutes with 0.06 inch maximum total excursion. 1 hour and 45 minutes in each of 3 mutually perpendicular planes. See Figure 7.

Figure 1 (continued)

Test Description	Requirement	Procedure
Mechanical shock, specified pulse.	No discontinuities of 1 microsecond or longer duration. See Note.	TE Spec 109-26-1, except 30 G's. Subject mated samples to 30 G's half-sine shock pulses of 11 milliseconds duration. 3 shocks in each direction applied along 3 mutually perpendicular planes, 18 total shocks. See Figure 7.
Durability.	See Note.	TE Spec 109-27. Mate and unmate samples for 200 cycles at a maximum rate of 10 cycles per minute. Modular jack/plug meet 750 mating and unmating cycles per AMP Specification 108-1163.
<b>ENVIRONMENTAL</b>		
Thermal shock.	See Note.	TE Spec 109-22. Subject samples to 100 cycles between -40 and 70°C.
Humidity-temperature cycling.	See Note.	TE Spec 109-23-4, Condition C. Subject samples to 21, 24 hour cycles between 25 and 65°C at 95% RH with -10°C cold shock.
Temperature life.	See Note.	TE Spec 109-43. Subject mated samples to temperature life at 70°C for 500 hours.

**NOTE**

*Shall meet visual requirements, show no physical damage, and meet requirements of additional tests as specified in the Product Qualification and Requalification Test Sequence shown in Figure 2.*

Figure 1 (end)

3.6. Product Qualification and Requalification Test Sequence

Test or Examination	Test Group (a)				
	1	2	3	4	5
	Test Sequence (b)				
Examination of product	1,6	1,5	1,8	1,6	1,5
Dry circuit resistance	2,5	2,4	2,7		
Insulation resistance				2,5	
Near end crosstalk					2
Attenuation					3
Return loss					4
Vibration	3				
Mechanical shock	4				
Durability			3,6(c)		
Thermal shock			4	3	
Humidity-temperature cycling			5	4	
Temperature life		3			

- NOTE**
- (a) See paragraph 4.1.A.
  - (b) Numbers indicate sequence in which tests are performed.
  - (c) Perform 100 cycles before thermal shock, 33 cycles after 50 cycles of thermal shock, 33 cycles after 7 days of humidity-temperature cycling, and 34 cycles after 21 days.

Figure 2

---

#### 4. QUALITY ASSURANCE PROVISIONS

##### 4.1. Qualification Testing

###### A. Sample Selection

Samples shall be prepared in accordance with applicable Instruction Sheets and shall be selected at random from current production. All test groups shall each consist of a minimum of 5 samples.

###### B. Test Sequence

Qualification inspection shall be verified by testing samples as specified in Figure 2.

##### 4.2. Requalification Testing

If changes significantly affecting form, fit or function are made to the product or manufacturing process, product assurance shall coordinate requalification testing, consisting of all or part of the original testing sequence as determined by development/product, quality and reliability engineering.

##### 4.3. Acceptance

Acceptance is based on verification that the product meets the requirements of Figure 1. Failures attributed to equipment, test setup or operator deficiencies shall not disqualify the product. When product failure occurs, corrective action shall be taken and samples resubmitted for qualification. Testing to confirm corrective action is required before resubmittal.

##### 4.4. Quality Conformance Inspection

The applicable quality inspection plan shall specify the sampling acceptable quality level to be used. Dimensional and functional requirements shall be in accordance with the applicable product drawing and this specification.

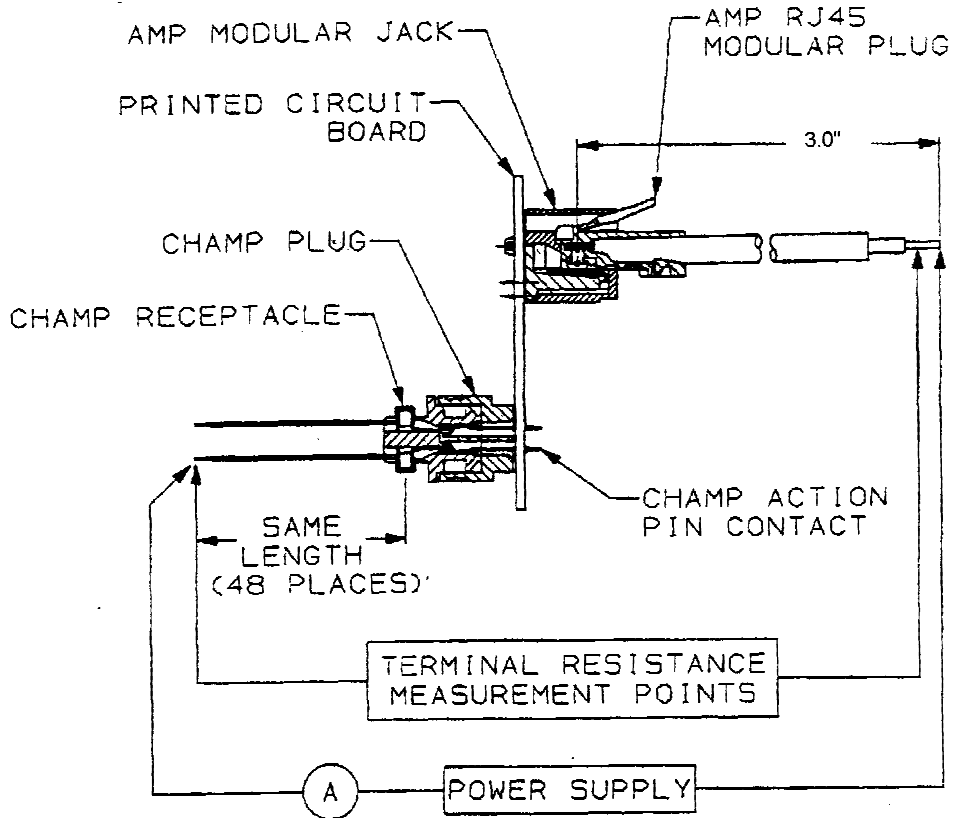

Figure 3  
Dry Circuit Resistance Measurement Points

Category 5, 100 Ohm Twisted Pair  
(See Note)

Frequency (MHZ)	NEXT Loss (crosstalk) (dB)	Attenuation (dB)	Return Loss (dB)
1.0	65.0	0.1	≥23
4.0	65.0	0.1	≥23
8.0	62.0	0.1	≥23
10.0	60.0	0.1	≥23
16.0	56.0	0.2	≥23
20.0	54.0	0.2	≥23
25.0	52.0	0.2	≥14
31.25	50.0	0.2	≥14
62.5	44.0	0.3	≥14
100.0	40.0	0.4	≥14

**NOTE** See EIA/TIA-TSB40-A and EIA/TIA-568-A.

Figure 4

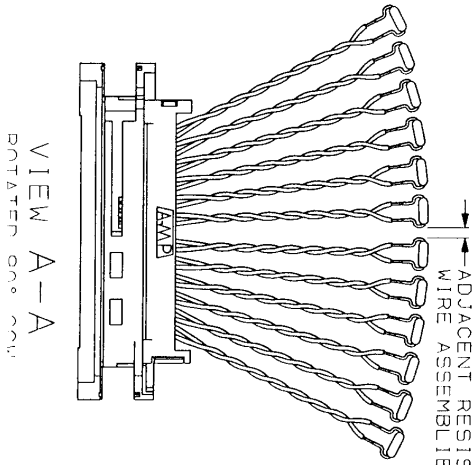
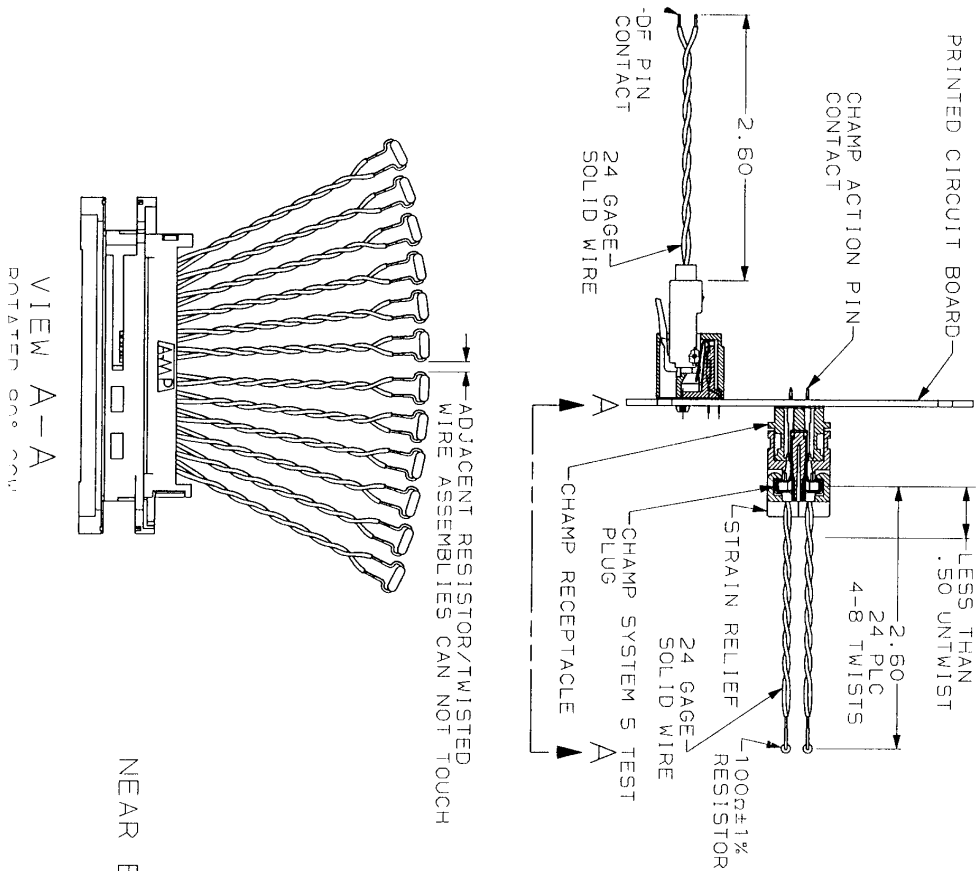

NEAR END CROSS TALK / RETURN LOSS TEST SET-UP

RESISTOR/TWISTED WIRE COMBINATIONS ON TEST PLUG

PAIR	TEST PLUG LOCATIONS	TEST PLUG LOCATIONS	PORTS
1	3	2	1, 7, 13 OR 19
2	8	4	PORTS
3	8	6	1, 7, 13 OR 19
4	7	8	PORTS
5	9 & 10	10	2, 8, 14 OR 20
6	11	12	PORTS
7	14	15	2, 8, 14 OR 20
8	16	17	PORTS
9	18	19	2, 8, 14 OR 20
10	20	21	PORTS
11	22	23	3, 9, 15 OR 21
12	24	25	PORTS
13	26	27	3, 9, 15 OR 21
14	29	29	PORTS
15	30	31	4, 10, 16 OR 22
16	32	33	PORTS
17	34	35	4, 10, 16 OR 22
18	36	37	PORTS
19	39	40	5, 11, 17 OR 23
20	41	42	PORTS
21	43	44	5, 11, 17 OR 23
22	45	46	PORTS
23	47	48	5, 11, 17 OR 23
24	49	50	PORTS
			5, 11, 17 OR 23
			PORTS
			6, 12, 18 OR 24

LOCATIONS 13 & 38 NOT USED

Figure 5  
Near End Cross Talk/Return Loss Test Set-Up

TWISTED WIRE  
COMBINATIONS ON TEST PLUG

<u>PAIR</u>	<u>TEST PLUG</u>	<u>LOCATIONS</u>
1	3	8
2	4	2
3	5	6
4	7	8
5	8 & 10	8
6	9	10
7	11 & 12	12
8	14 & 15	15
9	16 & 17	17
10	18 & 19	19
11	20 & 21	21
12	22 & 23	23
13	24 & 25	25
14	26 & 27	27
15	28 & 29	29
16	30 & 31	31
17	32 & 33	33
18	34 & 35	35
19	36 & 37	37
20	38 & 40	40
21	41 & 42	42
22	43 & 44	44
23	45 & 46	46
24	47 & 48	48
	49	49
	50	50

1, 7, 13 OR 19 PORTS  
2, 8, 14 OR 20 PORTS  
3, 9, 15 OR 21 PORTS  
4, 10, 16 OR 22 PORTS  
5, 11, 17 OR 23 PORTS  
6, 12, 18 OR 24 PORTS

LOCATIONS 13 & 38  
NOT USED

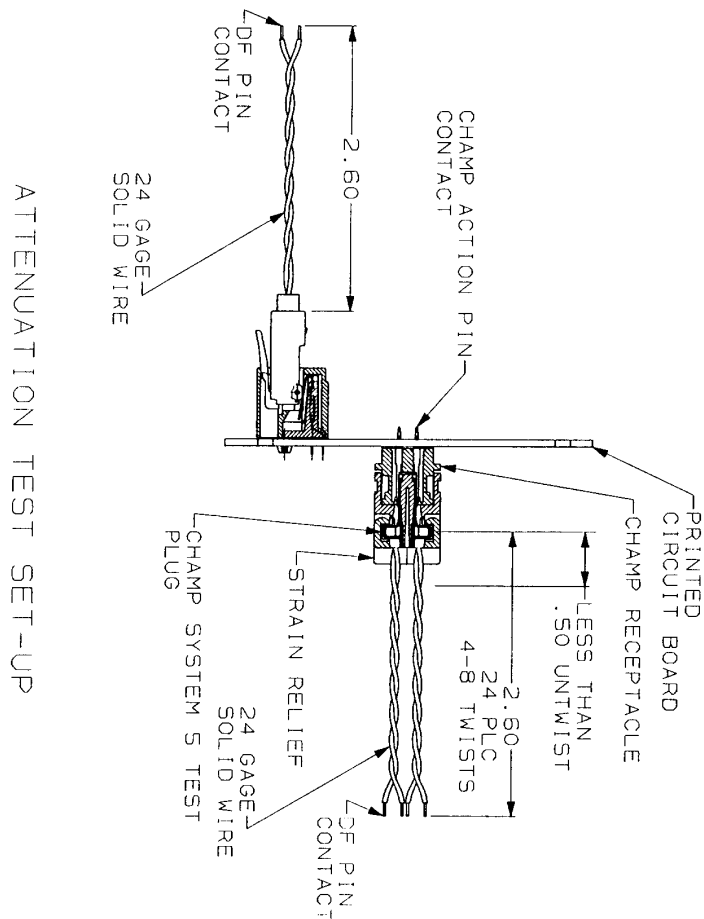

Figure 6  
Attenuation Test Set-Up



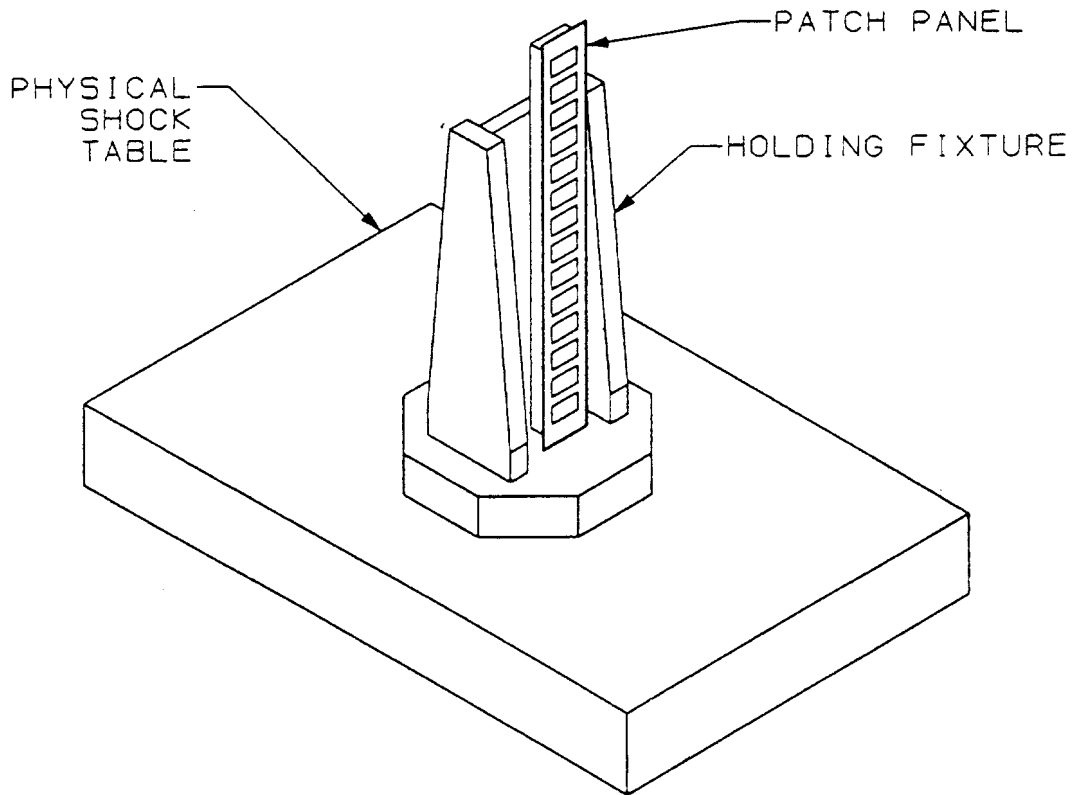
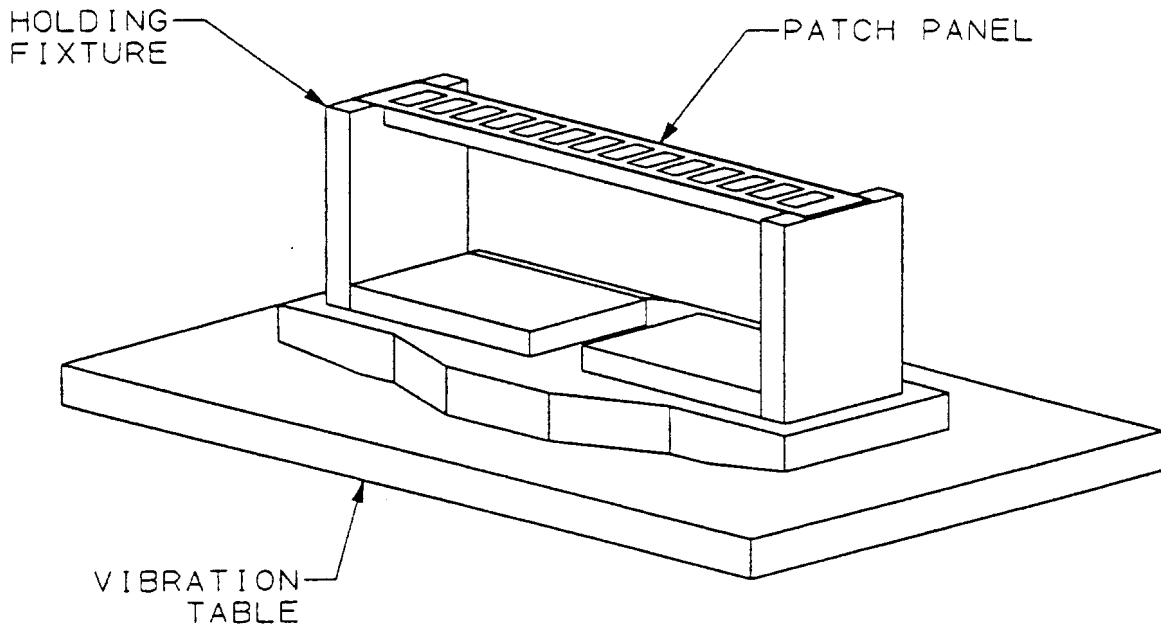

Figure 7  
Vibration & Physical Shock Mounting Fixtures