

MAXIFUSES HOLDERS WIRED

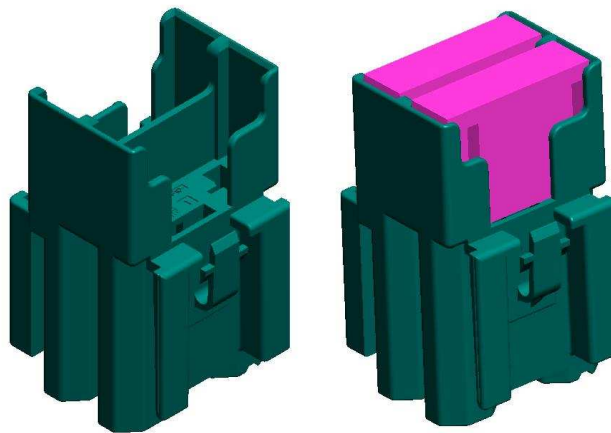
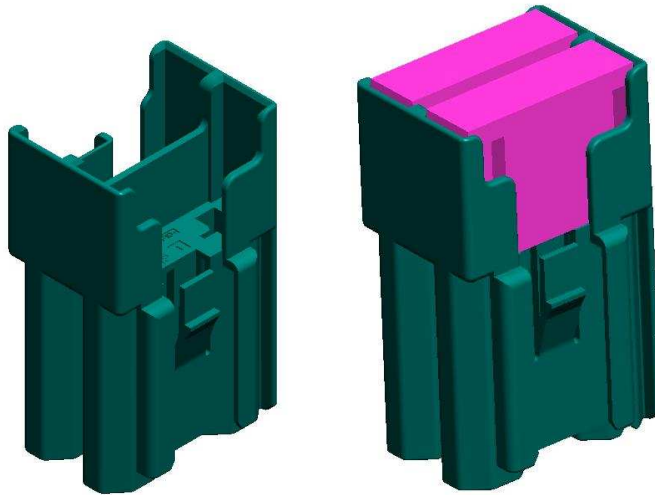

Rédigé par/*Drawing by* : E.MINY    le 28-Fev-2011    Approuvé par/*Approved by* : J.J. REVIL    le 28-Fev-2011

Tyco Electronics France SAS  
B.P. 30039, 95301 CERGY-PONTOISE Cedex

©2002 Tyco Electronics Corporation  
*All International Rights Reserved*  
(Tous droits réservés)

1 de 21

LOC F

Ce document est sujet à modifications. Contacter Tyco Electronics pour identifier la dernière révision et en obtenir une copie. Personnel Tyco Electronics : consultez la base de données Startec.

*This document, managed by Tyco Electronics France, is archived in the Startec database.  
A printout cannot be considered as a controlled document*

TABLE DES REVISIONS – *REVISION TABLE*

	<b>Révision</b>	<b>Date</b>	<b>Modification</b>
	1	19/11/2010	Initialisation
	2	31/01/2011	5.1 Change Test conditions, 5.2 program approval tests, appendix 1/2/3/4/5/6
	3	28/02/2011	Add ref Specifications RSA, add climatic endurance A5 at 150°C, change appendix 3 and Program approval tests

**CONTENTS:**

1. SCOPE	4
1.1. Content	4
2. DESCRIPTION	4
2.1. Maxifuses Holders	4
2.2. References	4
2.3. Electrical synoptic and fuse architecture: see appendix 1	4
2.4. Wiring architecture see appendix 2	4
2.5. Contacts used in the holders	4
3. REFERENCE DOCUMENTS	5
3.1. Usable document	5
3.2. Tyco Electronics specifications	5
4. Operating conditions	6
4.1. Temperatures	6
4.2. Watertightness & Protection rating	6
4.3. Vibration	6
4.4. Load scenario current at 85°C	6
5. TESTS	6
5.1. Test conditions:	6
6. QUALITY INSURANCE MEASURE	12
6.1. Qualification test	12
6.2. Program approval tests	13
6.3. General conditions of test	14
6.4. Test and conformity	14
Appendix 1 : fuses rating	15
Appendix 2 : Wiring architecture	16
Appendix 3 : Current load scenarios at 85°C	17
Appendix 4 : Contact resistance	18
Appendix 5: Vibration profil	19
Appendix 6: Temperature humidity cycle	20
Appendix 7: Description of mechanical tests on boxes	21

The product described in this document has not been fully tested to ensure conformance to the requirements outlined below. Therefore, TE makes no representation or warranty, express or implied, that the product will comply with these requirements. Further, TE may change these requirements based on the results of additional testing and evaluation. Contact TE Engineering for further details.

**1. SCOPE**

**1.1. Content**

This document covers the performances, tests, and quality requirements for Maxifuses Holders used on the engine compartment.

**2. DESCRIPTION**

**2.1. Maxifuses Holders**

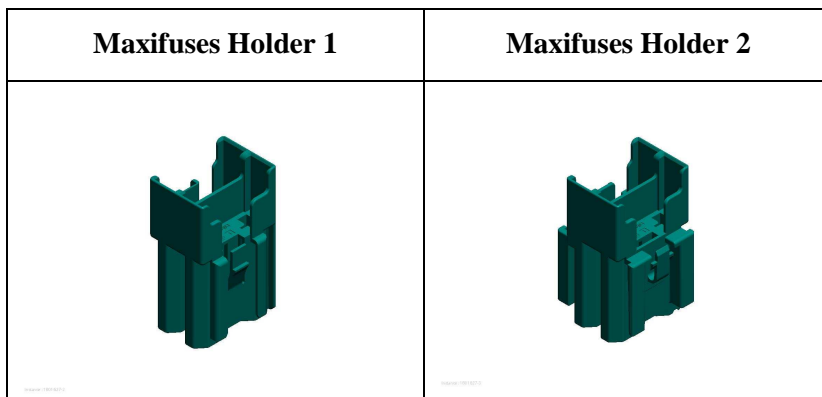

**2.2. References**

Tyco Electronics P/N	Description
1801627-2	MAXIFUSES HOLDER 1
1801627-3	MAXIFUSES HOLDER 2

**2.3. Electrical synoptic and fuse architecture:** \_\_\_\_\_ see appendix 1

**2.4. Wiring architecture** \_\_\_\_\_ see appendix 2

**2.5. Contacts used in the holders**

Clip, tab description	Wire (mm <sup>2</sup> )	Tyco Electronics P/N	Use
Clip 8 mm MAXIFUSE+	2,5 <sup>2</sup> to 4 <sup>2</sup>	0-1801431-1	Maxifuse
Clip 8 mm MAXIFUSE+	5 <sup>2</sup> à 6 <sup>2</sup>	0-1801432-1	Maxifuse
Clip 8 mm MAXIFUSE+	7 <sup>2</sup> à 10 <sup>2</sup>	0-1801433-1	Maxifuse

### **3. REFERENCE DOCUMENTS**

#### **3.1. Usable document**

In the event of conflict between the requirements of this specification and the drawing, the drawing shall take precedent.

In the event of conflict between the requirements of this specification and the referenced documents, this specification shall take precedent.

#### **3.2. Tyco Electronics specifications**

108-15392 rev A

8 mm MaxiFuse + contact

## 4. OPERATING CONDITIONS

### 4.1. Temperatures

Class(*)	Operating temperature	Test temperature *	
3	-40°C to 125°C	+150°C	For electrical connection a rea
2	-40°C to +100°C	+125°C	For locking devices

(\*): Without current load

### 4.2. Watertightness & Protection rating

- Watertightness: Class 0 - Unsealed

### 4.3. Vibration

- : See appendix 5

### 4.4. Load scenario current at 85°C

- : See appendix 3

## 5. TESTS

### 5.1. Test conditions:

- Supply voltage: 13.5V ± 0.5V
- Ambient temperature: 23°C ± 5°C
- Relative humidity: 60%± 15%
- Atmospheric pressure: 96kPa ± 10kPa
- If not over wised specified mechanical test: v = 50 mm/min
- Different holder configuration are defined:

	Plastic holder	Wire contact	Fuses
Configuration A	X		
Configuration B	X	X	
Configuration C	X	X	X

GENERAL INSPECTION				
	Test description	Ref. RSA <small>For indication</small>	Procedure	Requirement
<b>MAXIFUSES HOLDERS WIRED</b>				
V1	Visual inspection	36-05-019 § 6.1	Shall be performed with the naked eye.	No working damage No visible damage, cracking or defect.
MECHANICAL TESTS				
	Test description	Ref. RSA <small>For indication</small>	Procedure	Requirement
<b>MAXIFUSES HOLDER WIRED</b>				
M1	Insertion force inter boxes	36-05-219 § 7.2.4.1	→ Maxifuses Holders in configuration A  Make test according table 1 (see appendix 7)	▪ $F \leq 30$ N
M2	Removal force inter boxes	36-05-219 § 7.2.4.1	→ Maxifuses Holders in configuration A  Make test according table 1 (see appendix 7)	▪ $F \leq 60$ N
M3	Retention force inter boxes	36-05-219 § 7.2.4.1	→ Maxifuses Holders in configuration A  Make test according table 1 (see appendix 7)	▪ $F \geq 120$ N
M4	Shock impact test	36-05-219 § 7.3.1  36-05-019 § 6.21.	→ Maxifuses Holders in configuration A  Impact hammer weight: 300 gr Falling height: 100 mm The impact test described in NF R 13-415 Impact zone see appendix 7	▪ Visual examination: ▪ No break, cracking nor deformation
M5	Drop resistance	36-05-019 § 6.22.	→ Maxifuses Holders in configuration A and configuration C  1 m free fall test, on each face, on concrete floor. Test temperature : 0°C	No incipient rupture but unconcealed damage permissible

CONTACTS				
<b>M6</b>	<b>Terminal insertion</b>	36-05-219 § 7.2.4.5 36-05-019 § 5.3.4	<p>➔ Maxifuses Holders in configuration A</p> <p>Two insertion force measurement possible:</p> <ul style="list-style-type: none"> <li>. 1) Validation performed on a machine with a mobile jaw displacement speed of 50 mm/min ± 5 mm/min.</li> <li>. 2) The connector, installed on the measurement fixture, is manually loaded. The force is recorded at each insertion.</li> </ul>	<ul style="list-style-type: none"> <li>▪ 8 mm MaxiFuse + ≤ 20 N</li> </ul>
<b>M7</b>	<b>Terminal retention force</b>	36-05-219 § 7.2.4.5 36-05-019 § 5.3.5	<p>➔ Maxifuses Holders in configuration A</p> <p>The same measurement technique is used as the method described in M6 "terminal insertion".</p> <p>Under no circumstances must the mechanical strength of the wire be used as a reference.</p>	<ul style="list-style-type: none"> <li>▪ 8 mm MaxiFuse + &gt; 150 N</li> </ul> <p>After the ageing tests:</p> <ul style="list-style-type: none"> <li>▪ 8 mm MaxiFuse + &gt; 90 N</li> </ul>
FUSES				
<b>M8</b>	<b>Fuse insertion force</b>	36-05-219 § 7.2.4.2	<p>➔ Maxifuses Holders in configuration B</p>	<p>Fuse insertion force :</p> <ul style="list-style-type: none"> <li>▪ Maxifuse : <math>F &lt; 55 \text{ N}</math></li> </ul>
<b>M9</b>	<b>Fuse extraction force</b>	36-05-219 § 7.2.4.2	<p>➔ Maxifuses Holders in configuration B</p>	<p>Fuse extraction force:</p> <ul style="list-style-type: none"> <li>▪ Maxifuse: <math>30 \text{ N} \leq F \leq 100 \text{ N}</math></li> </ul>
<b>M10</b>	<b>Durability insertion and extraction components</b>	36-05-219 § 7.2.4.4	<p>➔ Maxifuses Holders in configuration B</p> <p>Mount and remove each fuse 10 times.</p> <ul style="list-style-type: none"> <li>- With 50% of the samples with the same component</li> <li>- With 50% of the samples with new component for each operations</li> </ul> <p>Record the first and the tenth:</p> <ul style="list-style-type: none"> <li>▪ Mounting and removing forces</li> <li>▪ Contact resistances</li> </ul>	<ul style="list-style-type: none"> <li>▪ Between the first to the tenth manipulation, the decrease must be lower than 20% of the 1<sup>st</sup> operation</li> <li>▪ Contact resistance Maxi (see E1)</li> </ul>
<b>M11</b>	<b>Protection of the contacts during the working and the handling</b>	36-05-219 § 6.4.4	<p>➔ Maxifuses Holders in configuration B</p> <p>Mount and remove each fuse 5 times in worst opposite combination clip/component.</p> <p>Record before the and after the test :</p> <ul style="list-style-type: none"> <li>▪ Contact resistances</li> <li>▪ Component removing forces</li> </ul>	<ul style="list-style-type: none"> <li>▪ Contact resistance Maxi (see E1)</li> <li>▪ Component removing force: the decrease must be lower than 20% of the 1st operation</li> </ul>



ELECTRICAL TESTS				
	Test description	Ref. RSA For indication	Procedure	Requirement
E1	<b>Contact resistance</b>	36-05-219 § 7.2.2  36-05-019 § 6.2	→ Maxifuses Holders in configuration C  “MilliVolts” level method: <ul style="list-style-type: none"> <li>▪ Test voltage : 20 mV</li> <li>▪ Test current : 50 mA</li> </ul>	Initial contact resistance: <ul style="list-style-type: none"> <li>▪ Maxifuse <math>\leq 4 \text{ m}\Omega</math></li> </ul> (see appendix 4) <ul style="list-style-type: none"> <li>▪ 8 mm MaxiFuse + <math>\leq 1 \text{ m}\Omega</math></li> </ul> After the ageing tests: <ul style="list-style-type: none"> <li>▪ Maxifuse <math>\Delta R_c \leq 4 \text{ m}\Omega</math></li> </ul> (see appendix 4) <ul style="list-style-type: none"> <li>▪ 8 mm MaxiFuse + <math>\Delta R_c \leq 1 \text{ m}\Omega</math></li> </ul>
E2	<b>Insulation resistance</b>	36-05-219 § 7.7  36-05-019 § 6.11	→ Maxifuses Holders in configuration C  Measures must be performed between each contacts and between each contacts connected together and a metal sheet covering the housing Voltage test : 500 V dc / 1 min	$R_i \geq 100 \text{ M}\Omega$
E3	<b>Voltage resistance</b>	36-05-219 § 7.6  36-05-019 § 6.12	→ Maxifuses Holders in configuration C  1 000 Vac eff. 50 Hz or 60 Hz (or 1400 Vcc) / 1 min between each contacts and between each contacts connected together and a metal sheet covering the housing	No dielectric breakdown or flash-over during the test. Contacts must be without damage, oxide trace, or all other defect Housing must be without damage
E4	<b>Fuse blowing test</b>	36-05-219 § 7.11	→ Maxifuses Holders in configuration C  A test shall be conducted to ensure that the holder is capable of resisting constraints associated with the utilization of fuses under limit conditions. The test is performed at ambient temperature.	<b>First test :</b> The holders are equipped with a « Maxifuse » 80 A fuse. No deformation shall appear following passage of a 108 A current between 60 s and 1800 s and a 160 A current between 4 s and 60 s.
E5	<b>Derating curve</b>	36-05-019 § 6.5	→ Maxifuses Holders in configuration C  Test performed following norm: IEC 605/2-5	$T_{\text{contact}} < T_{\text{max}} (125^\circ\text{C})$ Wire section tested: <ul style="list-style-type: none"> <li>▪ Maxifuse 40 A : 5 mm<sup>2</sup></li> <li>▪ Maxifuse 80 A : 10 mm<sup>2</sup></li> </ul>

	Test description	Ref. RSA For indication	Procedure	Requirement
T1	<b>Current cycling at high temperature</b>	36-05-219 § 7.4  36-05-019 § 6.15	<p>➔ Maxifuses Holders in configuration C.</p> <p>In an oven at 85°C, the holder is powered:</p> <ul style="list-style-type: none"> <li>▪ 500 cycles of scenario at 85°C (see appendix 3)</li> </ul> <p>1 cycle:</p> <ul style="list-style-type: none"> <li>▪ 45 min holders powered</li> <li>▪ 15 min holders not powered</li> </ul>	<ul style="list-style-type: none"> <li>▪ Contact resistance (see E1)</li> </ul>

AGEING TESTS				
	Test description	Ref. RSA For indication	Procedure	Requirement
A1	Atmospheric corrosion test	36-05-219 § 7.5.1  36-05-019 § 6.7	➔ Maxifuses Holders in configuration C.  Method regarding CEI 68-2-60 with <ul style="list-style-type: none"> <li>▪ Preconditioning : 1 H</li> <li>▪ Method : C</li> <li>▪ Duration : 4 H</li> </ul>	<ul style="list-style-type: none"> <li>▪ Contact resistance (see E1)</li> <li>▪ Visual inspection</li> </ul>
A2	Vibrations	36-05-219 § 7.3.2  36-05-019 E § 6.6	➔ Maxifuses Holders in configuration C. Vibration: Class 1 see appendix 5 Only on vertical axis	<ul style="list-style-type: none"> <li>▪ During sequence : No breakdown above 1 μs</li> <li>▪ Contact resistance (see E1)</li> </ul>
A3	Temperature humidity cycle	36-05-219 § 7.5.2  36-05-019 § 6.16	➔ Maxifuses Holders in configuration C. <ul style="list-style-type: none"> <li>▪ Holders not powered</li> <li>▪ 10 cycles of 24 Hrs.</li> </ul> Cycles described in appendix 6 Tmax = 125°C	<ul style="list-style-type: none"> <li>▪ Visual examination</li> <li>▪ Contact resistance ((see E1)</li> <li>▪ Withstanding voltage</li> <li>▪ Insulation resistance</li> </ul>
A4	Thermal shocks	36-05-219 § 7.5.3  36-05-019 § 6.17	➔ Maxifuses Holders in configuration C. <ul style="list-style-type: none"> <li>▪ Holders not powered</li> <li>▪ 100 cycles (1 cycle : 1 H / -40°C + 1 H / +125°C)</li> <li>▪ transient time &lt; 15 s</li> </ul>	<ul style="list-style-type: none"> <li>▪ Visual examination</li> <li>▪ Contact resistance (see E1)</li> </ul>
A5	Climatic endurance	36-05-219 § 7.5.4  36-05-019 § 6.19	➔ Maxifuses Holders in configuration C. <ul style="list-style-type: none"> <li>▪ Holders not powered</li> <li>▪ 240 Hrs at 125°C</li> </ul>	<ul style="list-style-type: none"> <li>▪ No visible deformation nor crack</li> <li>▪ Contact resistance (see E1)</li> </ul>
A6	Climatic endurance	36-05-219 § 7.5.4  36-05-019 § 6.19	➔ Maxifuses Holders in configuration B. <ul style="list-style-type: none"> <li>▪ Holders not powered</li> <li>▪ 240 Hrs at 150°C</li> </ul>	<ul style="list-style-type: none"> <li>▪ No visible deformation nor crack</li> </ul>

OTHER TESTS				
	Test description	Ref. RSA For indication	Procedure	Requirement
O1	Speed of combustibility	36-05-219 § 7.9.1	Test on standard material sample According test method D45 1333	Combustibility rate < 70 mm/min
O2	Glow wire test	36-05-219 § 7.9.2	→ Maxifuses Holders in configuration C  Test method D45 1730 with Wire temperature 750°C ± 10°C Duration of incandescent wire application is 30 s ± 1 s	No presence of a flame shall be observed 30 seconds after the incandescent wire has been moved away.
O3	Resistance to fluids	36-05-019 § 6.18	→ Maxifuses Holders in configuration A  The tests are performed in accordance with Test Method D47 1924. Test with the following fluids:  Engine oil Battery electrolyte Mechanical gearbox oil Coolants Brake fluid Fuels  "Severely cold" windscreen washing fluid,	At the end of the test, the parts tested must meet the following test requirements: <ul style="list-style-type: none"> <li>▪ No deformation or cracks shall be observed.</li> <li>▪ Voltage resistance.</li> <li>▪ Terminal resistance variation, ΔRc,</li> </ul>

## 6. QUALITY INSURANCE MEASURE

### 6.1. Qualification test

Samples must be in accordance with drawings and be taken in a random way in the production in progress.

6.2. Program approval tests

In the groups defined below, the boxes undergo all the tests in the chronological order of the figure

N° Sequence	Component number 1801627-2	Component number 1801627-3	Tests
1	10	10	M1 36-05-219 § 7.2.4.1 Insertion force inter boxes M2 36-05-219 § 7.2.4.1 Removal force inter boxes M3 36-05-219 § 7.2.4.1 Retention force inter boxes
2	8	8	M4 36-05-019: 6.21 Shock impact V1 36-05-019: 6.1 Visual inspection
3	24	24	M5 36-05-019: 6.22 Drop test
4	10	10	M6 36-05-019 § 5.3.4 Terminal insertion M7 36-05-019 § 5.3.5 Terminal retention force
5	10	10	M8 36-05-219: 7.2.4.2 Fuses insertion force M9 36-05-219: 7.2.4.2 Fuses extraction force
6	4	4	E5 36-05-019 § 6.5 Derating curve
7	4	4	M10 36-05-219: 7.2.4.4 Durability insertion and uncoupling components E1 36-05-019: 6.2 Contact resistance
8	1	1	A1 36-05-019: 6.7 Atmospheric corrosion E1 36-05-019: 6.2 Contact resistance
9	4	4	A2 36-05-019: E: 6.6 Vibrations E1 36-05-019: 6.2 Contact resistance
10	4	4	A3 36-05-019: 6.16 Temperature/humidity V1 36-05-019: 6.1 Visual inspection
11	4	4	A4 36-05-019: 6.17 Thermal shock V1 36-05-019: 6.1 Visual inspection
12	4	4	A5 36-05-219: 7.5.4 36-05-019: 6.19 Climatic endurance 125°C Class T2 E1 36-05-019: 6.2 Contact resistance
13	4	4	A6 36-05-219: 7.5.4 36-05-019: 6.19 Climatic endurance 150°C Class T3 M7 36-05-019 § 5.3.5 Terminal retention force
14	4	4	O3 36-05-019: 6.18 Resistance to fluids V1 36-05-019: 6.1 Visual inspection
15	4	4	E1 36-05-019: 6.2 Contact resistance M11 Protection of the contacts during the working and the handling E1 36-05-019: 6.2 Contact resistance
16	4	4	E4 36-05-219: 7.11 Fuses blowing test M9 36-05-219: 7.2.4.2 Fuses extraction force
17	Plastic material certificate		O1 36-05-219: 7.9.1 Speed of combustibility E1 36-05-019: 6.2 Contact resistance
18	4	4	O2 36-05-219: 7.9.2 Glow wire test

### **6.3. General conditions of test**

Unless otherwise specified, the tests are conducted in the following conditions.  
Minimum test samples quantity: 2 parts (1 by cavity)

The table below gives the number of samples for a complete qualification.

### **6.4. Test and conformity**

Conformity test is made regarding specific Tyco Electronics quality inspection plan which define acceptable quality limit based on number of samples.  
Dimensional and functional requirement must meet production drawing and that specification.

**APPENDIX 1: FUSES RATING**

**2MAXIFUSES HOLDER**

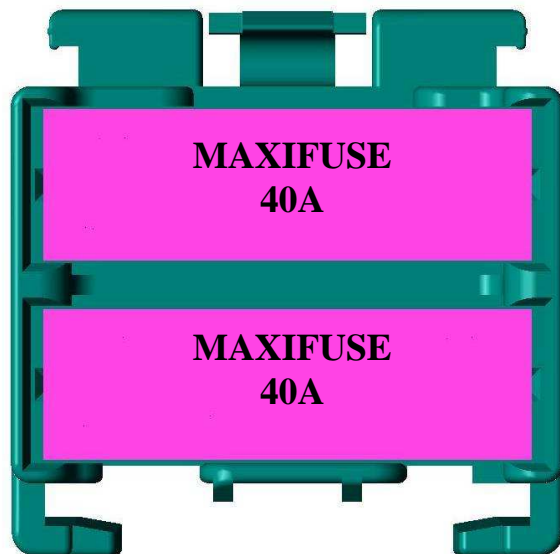
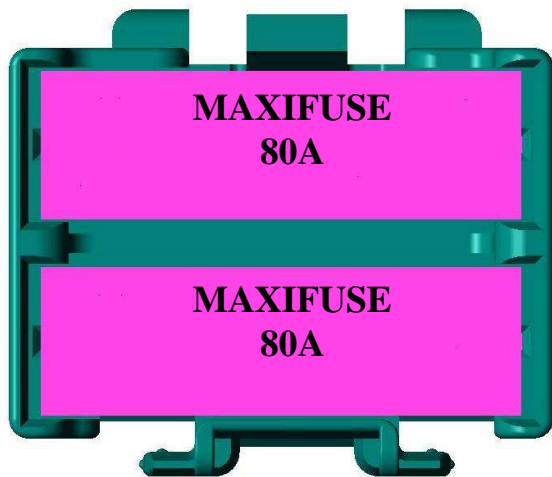

**APPENDIX 2: WIRING ARCHITECTURE**

**2MAXIFUSES HOLDER**

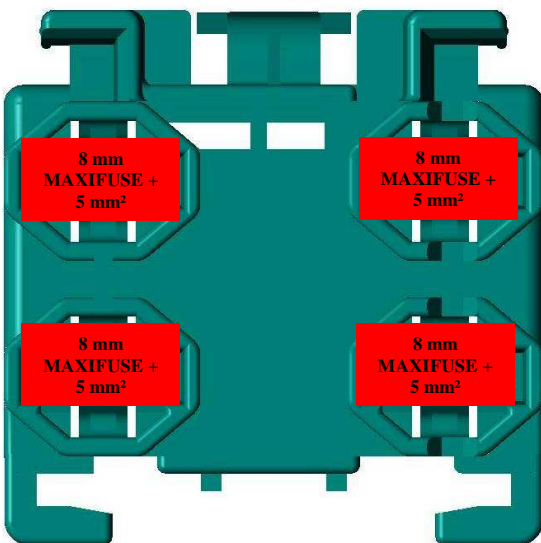
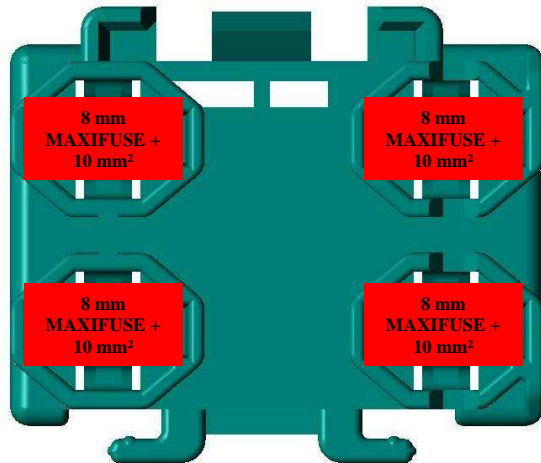



**APPENDIX 3: CURRENT LOAD SCENARIOS AT 85°C**

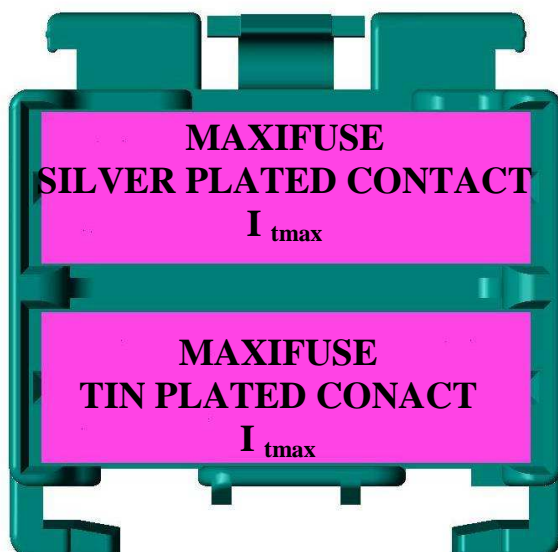
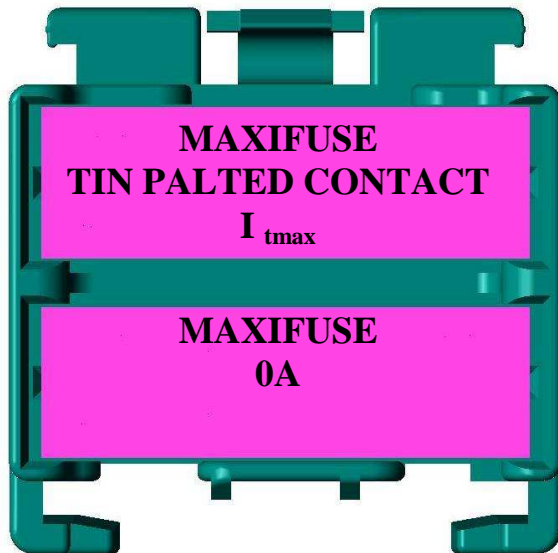

FOR INFORMATION

$I_{tmax}$  is the current that heat up the contact zone at 125°C (given by derating curve).

---

#### APPENDIX 4: CONTACT RESISTANCE

Contact resistance measurement for fuses:

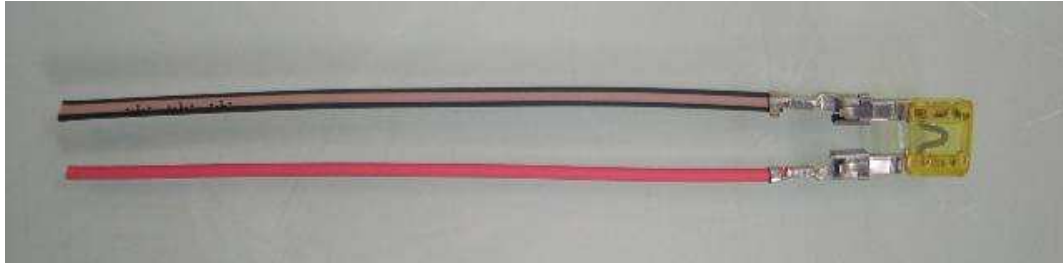

The wire length is 100mm.

The resistance of:

    The fuse,

    The two wires

are removed from the resistance measurement.

The criterion of acceptance is the sum of both connexions on the both fuse tabs.

**APPENDIX 5: VIBRATION PROFIL**

- Temperature cycling during vibration endurance test:

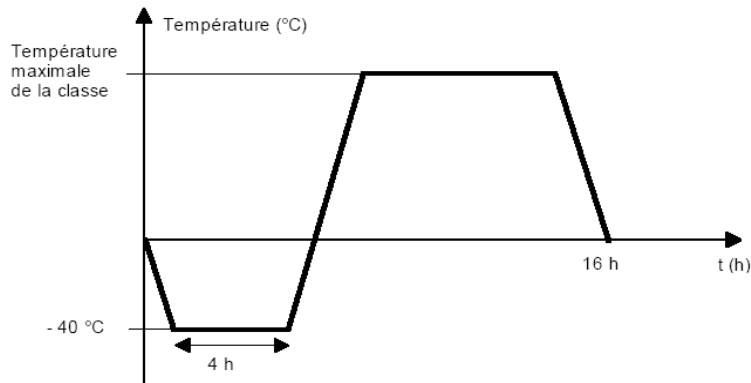

Tmin = -40°C  
 Tmax = +100°C  
 Temperature variation:  
 40°C/hour  
 Maintaining at extreme  
 temperature: 4H

- Vibration profile:

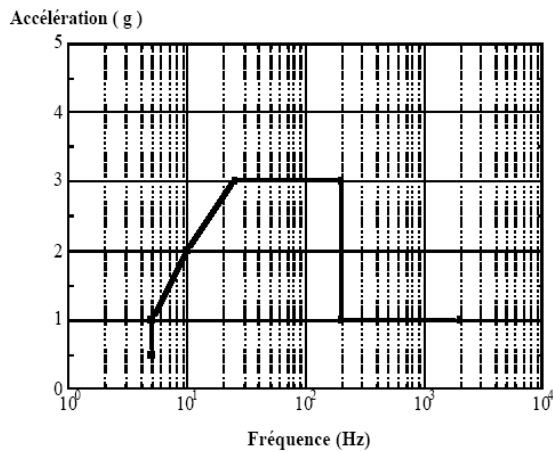

Fréquences	Accélération
5 Hz	0,5 g à 1 g
10 Hz	2 g
25 Hz à 200 Hz	3 g
200 Hz	3 g à 1g
200 Hz à 2000 Hz	1 g

**APPENDIX 6: TEMPERATURE HUMIDITY CYCLE**

Tmax = 125°C

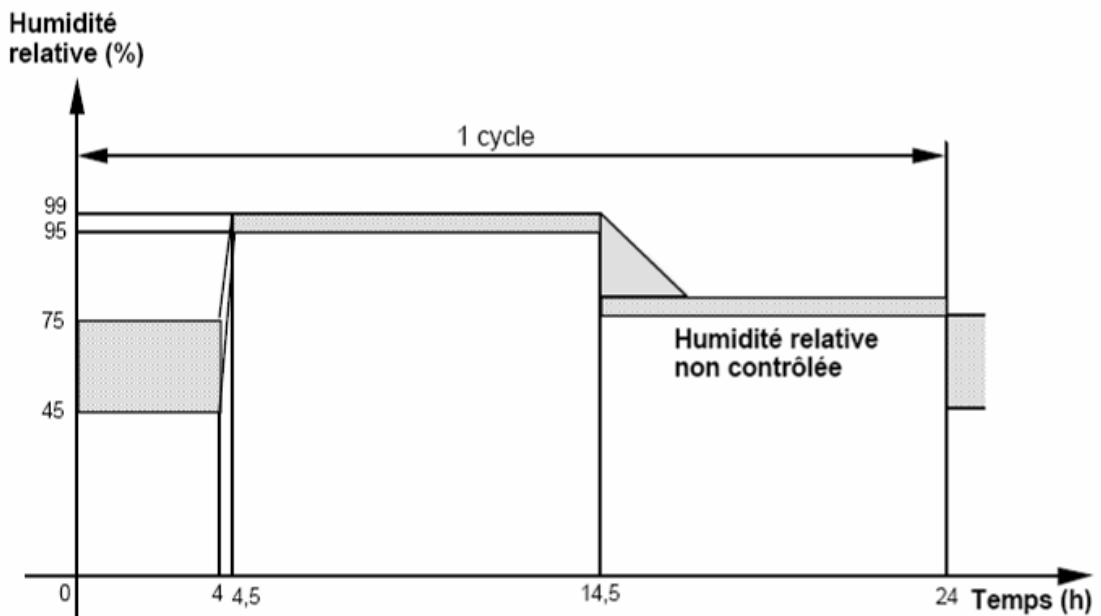
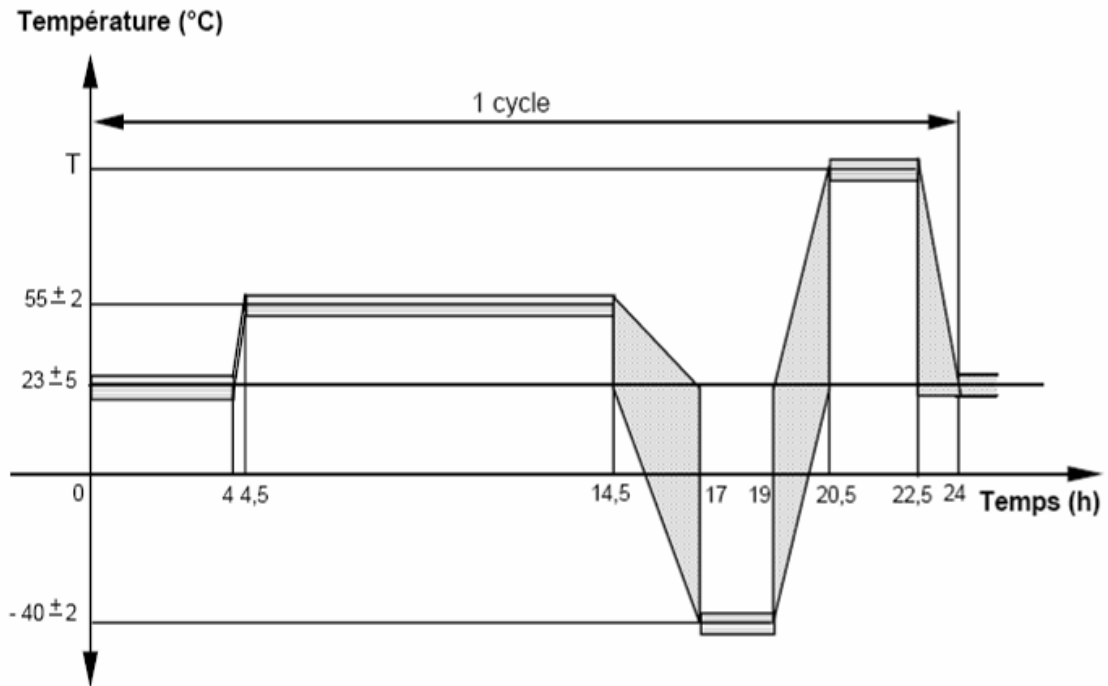

**APPENDIX 7: DESCRIPTION OF MECHANICAL TESTS ON BOXES**

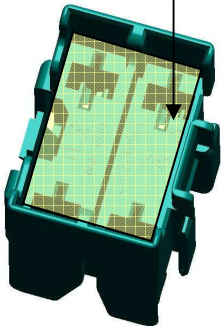
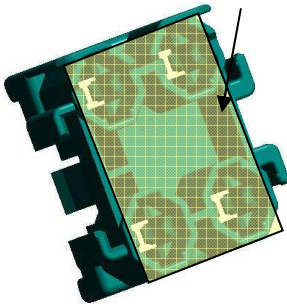
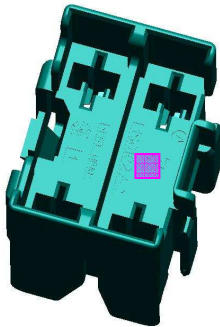
	Insertion test	Removal test Locking system inactive	Retention forces test	Area for shock impact test
2 MAXIFUSES HOLDER WIRED 1				
2 MAXIFUSES HOLDER WIRED 2	