



Power Versa-Lock Connector Systems

1. SCOPE

1.1. Content

This specification covers performance, tests, and quality requirements for the Power Versa-Lock Panel Mount and Twist and Lock connector systems.

1.2. Qualification

When tests are performed on the subject product line, procedures specified in Figure 1 shall be used. All inspections shall be performed using the applicable inspection plan and product drawing. All contacts must be crimped to comply with the Application Specification listed below using the appropriate TE Applicator or Hand Tool specified in that document.

2. APPLICABLE DOCUMENTS AND FORMS

The following documents form a part of this specification to the extent specified herein. Unless otherwise specified, the latest edition of the document applies. In the event of conflict between the requirements of this specification and the product drawing, the product drawing shall take precedence. In the event of conflict between the requirements of this specification and the referenced documents, this specification shall take precedence.

2.1. TE Connectivity Specifications

| | |
|----------------------------|--|
| 114-143082 | Application Specification – Power Versa-Lock Connector Systems |
| 501-139215 | Qualification Test Report |
| 502-160860 | 3x3 Test Report |
| 502-161610 | 3x3 Temperature life test report |

2.2. Commercial Standards and Specifications

| | |
|-----------|---|
| EIA-364 | Electrical Connector/Socket Test Procedures Including Environmental Classifications |
| IEC 60335 | International Standard – Household and Similar Electrical Appliances – Safety |
| IEC 60512 | International Standard – Connectors for Electronic Equipment |
| IEC 60529 | International Standard – Degrees of Protection Provided by Enclosures (IP Code) |

2.3. Reference Documents

| | |
|-----------------------|----------------------------------|
| 109-1 | General Requirements for Testing |
|-----------------------|----------------------------------|

3. REQUIREMENTS

3.1. Design and Construction

Product shall be of the design, construction, materials and physical dimensions specified on the applicable product drawing.

3.2. Materials

Materials used in the construction of this product shall be as specified on the applicable TE drawing.

3.3. Ratings

- A. Voltage Rating: 600 VAC/VDC
- B. Current Rating: See Figure 5
- C. Temperature Rating (includes ambient temperature plus thermal increase due to current flow):

- -30°C to +140°C with use of contacts (-1) and housing (sealed and unsealed applications)

3.4. Performance Requirements and Test Description

The product should meet the electrical, mechanical and environmental performance requirements specified in Figure 1. All tests shall be performed at ambient environmental conditions otherwise specified.

3.5. Test Requirements and Procedure Summary

| Test Description | Requirement | Procedure |
|---------------------------------|---|---|
| Examination of Product | Meet requirements of product drawing and TE application specification. After testing, there shall be no corrosive influence on the performance and no physical damage that would impair product performance. | EIA-364-18 Visual and dimensional (C of C) inspection per the product drawing. |
| Electrical | | |
| Termination Resistance | Initial: 10 mΩ (milliohm) (maximum) Final: 20 mΩ (milliohm) (maximum) | EIA-364-23 Subject contacts assembled in a housing to 20mV (max.) open circuit at 10 mA. Subtract the resistance of the wire from the measurement. Connection per Figure 4. |
| Insulation Resistance | Initial: 1000 MΩ (minimum) Final: 500 MΩ (minimum) | EIA-364-21 Apply 500 VDC and hold for 2 minutes. Test between contacts in adjacent circuits and between housing and contacts in a mated connector. |
| Dielectric Withstanding Voltage | 1 minute hold without a creep discharge or flashover. Current Leakage: 5 mA (maximum) | EIA-364-20, Method A, Condition 1 Hold at 2.2 kV AC at sea level for 1 minute. Current Leakage: 5 mA (maximum) Test between contacts in adjacent circuits and between housing and all contacts in a mated connector. |
| Mechanical | | |
| Temperature Rise vs. Current | 30°C maximum when subjected to rated current | EIA-364-70, Method 1 Measure the temperature rise above ambient created by the energizing current. Measurement must be taken at a place where there is no influence from air convection. Contacts to be assembled in housing with all circuits connected. The thermocouple is to be attached to the contact in the center circuit. Stabilize at a single current level until 3 readings at 5 minute intervals are within 1°C. |
| Sinusoidal Vibration | No electrical discontinuity greater than 1 μs shall occur. No physical damage that would impair product performance. | EIA-364-28, Condition I Subject mated connector to 10-55-10 Hz traversed in 1 minute at 1.52 mm amplitude. Apply 2 hours in each of 3 mutually perpendicular planes. 100 mA applied. |

Figure 1 (continued)

| Test Description | Requirement | Procedure |
|---|--|--|
| Mechanical Shock | No electrical discontinuity greater than 1 μ s shall occur. No physical damage that would impair product performance. | EIA-364-27, Condition A Subject mated connector to 50G's half-sine shock pulse of 11 ms duration. 3 drops each to normal and reversed directions of X, Y and Z axis. Total of 18 drops. |
| Durability | No physical damage that would impair product performance. | EIA-364-9 Manually mate and unmate connectors for 25 cycles. |
| Connector Mating Force | Unsealed: (10.0 x no. of Positions) N (maximum) Sealed: (18 x no. of Positions) N (maximum) | EIA-364-13, Method A Operation Speed: 25.4 mm/min Measure the force required to mate connectors without locking latches. |
| Unmating Force | (1.25 x # of Positions) N (minimum) | EIA-364-13, Method A Operation Speed: 25.4 mm/min Measure the force required to unmate connectors. |
| Crimp Tensile Strength | Wire Size (AWG [mm²]) | Crimp Tensile (minimum) (N [kgf]) |
| | 26 [0.14] | 19.6 [2] |
| | 24 [0.22] | 29.4 [3] |
| | 22 [0.31] 2x22 [2x0.31] | 49.0 [5] |
| | 20 [0.51] | 60 [6.1] |
| | 18 [0.87] | 90 [9.2] |
| | 16 [1.27] | 135 [13.8] |
| | 14 [1.63] | 200 [20.4]* |
| EIA-364-8 Operation Speed: 25.4 mm/min Apply an axial pull force to the crimped wire. Contact to be secured to the tester. Insulation barrel crimp to be disabled. *Contact must be held in a fixture during testing to equalize forces during testing. | | |
| Housing Panel Retention Force | 98 N (minimum) | EIA-364-97 Operation Speed: 100 mm/min. Measure panel retention force using a panel cut with nominal dimensions as specified in the TE customer drawing. |
| Housing Locking Strength | 66.7 N (minimum) | EIA-364-98 Operation Speed: 13 mm/min Ensure that locking latches are fully engaged. |
| Contact Insertion Force | 13.3 N (maximum) per contact | EIA-364-5 |
| Contact Retention Force | With TPA accessory: 66.7 N [15 lbf] (minimum) Without TPA accessory: 53.4 N [12 lbf] (minimum) | EIA-364-29, Method A Operation Speed: 25.4 mm/min Measure the axial force required to remove contact from the housing with and without a TPA accessory. |

Figure 1 (continued)

| Test Description | Requirement | Procedure |
|--|---|--|
| Environmental | | |
| Thermal Shock | No physical damage that would impair product performance. | EIA-364-32, Method A, Test Condition I Subject mated specimens to 25 cycles between – 55°C and 85°C with 30 minute dwell time at temperature extremes and 5 minute transition (maximum) between temperatures. |
| Humidity-Temperature Cycling | No physical damage that would impair product performance. | EIA-364-31, Method IV Subject mated specimen to 10 cycles between 25°C and 65°C at 80-100% RH. 1 cycle is 24 hours. |
| Temperature Life | No physical damage that would impair product performance. | EIA-364-17, Method A, Subject mated connector to 140°C for a duration of 96 hours. Measurements to be recorded after specimens are held for 3 hours at ambient temperature and humidity. |
| Water Immersion (Sealed version only) | No ingress of water or physical damage that would impair product performance. | IEC 60529, Test Conditions per IP67 requirements Immerse mated samples in water for 30 minutes with the lowest point of the sample 1 meter below the surface. Tank must be 8 inches (minimum) in diameter. *Refer to Customer Drawing for applicable wire insulation range |
| Dust Tightness (Sealed version only) | No ingress of dust or physical damage that would impair product performance. | IEC 60529, Test Conditions per IP67 requirements Subject mated connector to 8 hours of circulating talcum powder dust. 2 kg of powder per cubic meter of test chamber shall be used. *Refer to Customer Drawing for applicable wire insulation range |
| Resistance to Cold | No physical damage that would impair product performance. | IEC 60512-11-10 Subject mated connector to –30°C ± 2°C for 96 hours. Measurements to be recorded after specimens are held for 3 hours at ambient temperature and humidity. |
| Salt Spray | No physical damage that would impair product performance. | EIA-364-26, Condition B Subject mated connectors to 5±1% salt concentration for 48 hours. |
| GWEPT 850°C & 750°C (Glow wire version only) | For Glow wire versions, test at 850°C (Flame duration <=30 seconds after probe removal) and at 750°C (Flame duration <= 2 seconds). Lighted tissue paper shall not burn. | IEC 60695-2-11 and IEC 60335-1 Tests to be conducted on each of 3 perpendicular sides. Perform a visual check and take picture after the test. |

Figure 1 (end)

**NOTE**

Shall meet visual requirements, show no physical damage, and meet requirements of additional tests as specified in the Product Qualification and Requalification Test Sequence shown in Figure 2.

3.6. Product Qualification and Requalification Test Sequence

| TEST OR EXAMINATION | TEST GROUP (a) | | | | | | | | | | |
|---------------------------------|-------------------|------------------------|----------------------------|---------------------------|----------------------------|-------------------------|-------------------------|-------------------------|-------------------------|-------------|--------------------|
| | 1 Mechanical | 2 Current Rating | 3 Housing Electrical | 4 Contact Retention | 5 Housing Mechanical | 6 Dust/ Water (d) | 7 Environ- mental | 8 Environ- mental | 9 Environ- mental | 10 Crimp | 11 Glow Wire |
| | TEST SEQUENCE (b) | | | | | | | | | | |
| Examination of Product | 1, 9 | 1, 5 | 1, 9 | 1, 4 | 1, 4 | 1, 4 | 1, 5 | 1, 5 | 1, 5 | 1, 3 | 1, 3 |
| Termination Resistance | 3, 7 | 2, 4 | | | | | 2, 4 | 2, 4 | 2, 4 | | |
| Insulation Resistance | | | 2, 7 | | | | | | | | |
| Dielectric Withstanding Voltage | | | 3, 8 | | | | | | | | |
| Temperature Rise vs. Current | | 3 | | | | | | | | | |
| Sinusoidal Vibration | 5 | | | | | | | | | | |
| Mechanical Shock | 6 | | | | | | | | | | |
| Durability | 4 | | | | | | | | | | |
| Mating Force | 2 | | | | | | | | | | |
| Unmating Force | 8 | | | | | | | | | | |
| Crimp Tensile Strength | | | | | | | | | | 2 | |
| Housing Panel Retention Force | | | | | 2 | | | | | | |
| Housing Lock Strength | | | | | 3 | | | | | | |
| Contact Insertion Force | | | | 2 | | | | | | | |
| Contact Retention Force | | | | 3 | | | | | | | |
| Thermal Shock | | | 4 | | | | | | | | |
| Humidity-Temperature Cycling | | | 5 | | | | | 3(c) | | | |
| Temperature Life | | | | | | | | | 3 | | |
| Water Immersion | | | | | | 2 | | | | | |
| Dust Tightness | | | | | | 3 | | | | | |
| Resistance to Cold | | | 6 | | | | | | | | |
| Salt Spray | | | | | | | 3 | | | | |
| Glow Wire | | | | | | | | | | | 2 |

Figure 2



NOTE

- (a) See paragraph 4.2.
- (b) Numbers indicate sequence in which tests are performed.
- (c) Connectors for these tests shall be preconditioned with 5 durability cycles.
- (d) Perform test group on samples with individual wire seals or rear gang seals only.
- (e) Connectors for these tests shall be preconditioned with 10 durability cycles.

4. QUALITY ASSURANCE PROVISIONS

4.1. Test Conditions

Unless otherwise specified, all the tests shall be performed in any combination of the following test conditions shown in Figure 3.

| | |
|----------------------|------------------|
| Temperature | 15°C – 35°C |
| Relative Humidity | 45% – 75% |
| Atmospheric Pressure | 86.6 – 106.6 kPa |

Figure 3

4.2. Qualification Testing

A. Specimen Selection

Specimens shall be prepared in accordance with applicable instruction and application sheets and shall be selected at random from current production.

B. Test Sequence

Qualification inspection shall be verified by testing specimens as specified in Figure 2.

4.3. Requalification Testing

If changes significantly affecting form, fit or function are made to the product or manufacturing process, product assurance shall coordinate requalification testing, consisting of all or part of the original testing sequence as determined by development/product, quality and reliability engineering.

4.4. Acceptance

Acceptance is based on verification that the product meets the requirements in Figure 1. Failures attributed to equipment, test setup or operator deficiencies shall not disqualify the product. If product failure occurs, corrective action shall be taken and specimens resubmitted for qualification. Testing to confirm corrective action is required before resubmittal.

4.5. Quality Conformance Inspection

The applicable quality inspection plan shall specify the sampling acceptable quality level to be used. Dimensional and functional requirements shall be in accordance with the applicable product drawing and this specification.

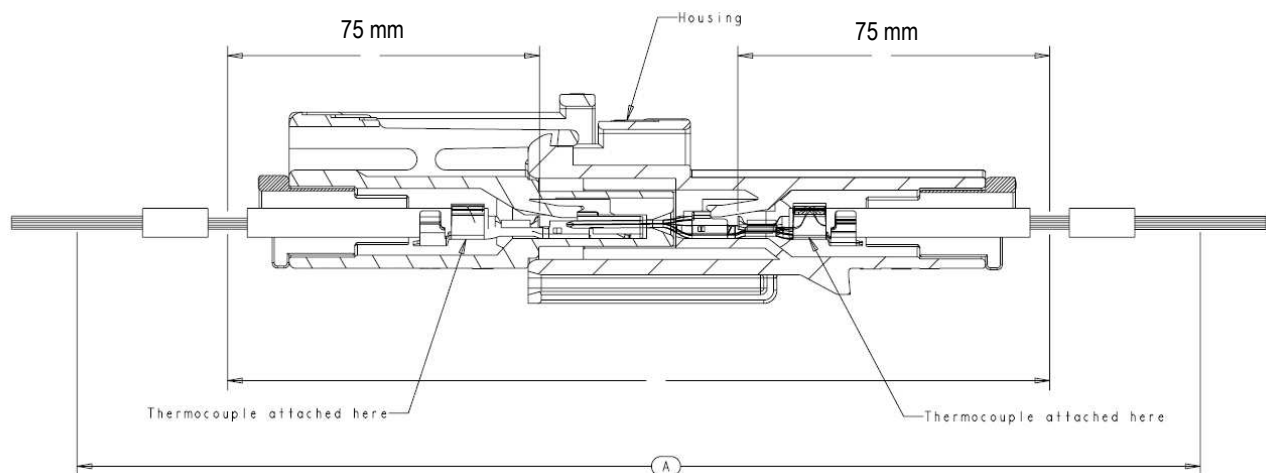

Figure 4

| Position | Wire Size | | | | | | | |
|----------|-----------|--------|--------|--------|--------|--------|--------|--------------|
| | 14 AWG | 16 AWG | 18 AWG | 20 AWG | 22 AWG | 24 AWG | 26 AWG | 2x22 AWG (a) |
| 1P-2P | 15 A | 12 A | 8 A | 7 A | 5 A | 4 A | 3 A | 6 A |
| 3P-4P | 11 A | 9 A | 7 A | 6 A | 4 A | 3 A | 2 A | 5 A |
| 6P-9P | 10 A | 8 A | 6 A | 5 A | 3 A | 2 A | 2 A | 4 A |

Figure 5: Current Rating



NOTE

(a) Current shown is the maximum combined for both wires with the current in each wire not to exceed 50% of the total current.