



---

## DYNAMIC D4950 Connector

---

### 1. SCOPE

#### 1.1. Content

This specification covers the requirements for product performance, test methods and quality assurance provisions of Dynamic D4950 Connector.

#### 1.2. Qualification

When tests are performed on the subject product line, procedures specified in Figure 1 shall be used. All inspections shall be performed using the applicable inspection plan and product drawing.

#### 1.3. Qualification Test Results

Successful qualification testing on the subject product line has not been completed. The Qualification Test Report number will be issued upon successful qualification testing.

### 2. APPLICABLE DOCUMENTS AND FORMS

The following documents and forms constitute a part of this specification to the extent specified herein. Unless otherwise indicated, the latest edition of the document applies.

#### 2.1. TE Documents

- 408-78173: Application Specification
- 501-78746: Qualification Test Report (Rev A)

#### 2.2. Industry Documents

- EN 61984: Connectors – Safety requirements and tests
- IEC 60068: Environmental testing
- IEC 60512: Connectors for electronic equipment – Test and measurements
- IEC 60664-1: Insulation coordination for equipment within low-voltage systems(Part 1)
- EN 61373: Railway application – Rolling stock equipment – Shock and vibration test
- IEC 60947-7-1: Low-voltage switchgear and controlgear
- UL1059: Standard for Safety for Terminal Blocks
- EIA364: Electrical Connector Performance Test Standards

### 3. REQUIREMENTS

#### 3.1. Design and Construction

Product shall be of the design, construction, materials and physical dimensions specified on the applicable product drawing.

#### 3.2. Ratings

- Operating temperature including temperature rising: -55°C~+125°C
- Assembling ambient temperature: -5°C~+45°C

- Applicable wire, Voltage and Current (UL1059)

Applicable wire: AWG16-10 Solid and Stranded  
 Voltage (Class B): 300V AC/DC  
 Voltage (Class C): 300V AC/DC  
 Voltage (Class D): 600V AC/DC 5A max

Number of energized contacts	Current(A)			
	AWG16	AWG14	AWG12	AWG10
8	10	15	19	22

- Applicable wire, Voltage and Current (IEC61984/IEC60947-7-1)

Applicable wire: 1.5SQ-4SQ Solid/stranded  
 1.5SQ-2.5SQ flexible  
 Voltage (Pollution Degree:2 , Protection Class:II ): 630V AC/DC  
 Voltage (Pollution Degree:2 , Protection Class:III ): 600V AC/DC  
 Voltage (Pollution Degree:3 , Protection Class:III ): 400V AC/DC

Number of energized contacts	Current(A)		
	1.5SQ	2.5SQ	4SQ
8	16	18	24

Derating Curve(8POSN)

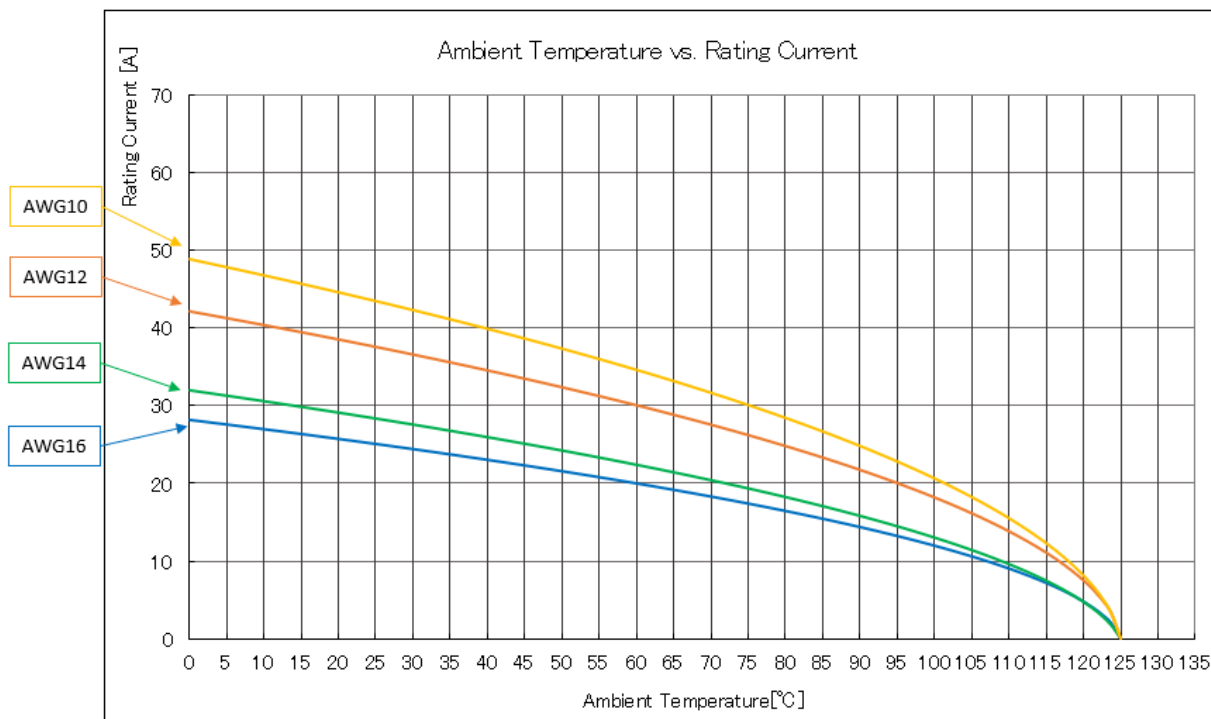

### 3.3. Test Requirements and Procedures Summary

Unless otherwise specified, all tests shall be performed at ambient environmental conditions.

No.	TEST DESCRIPTION	REQUIREMENT	PROCEDURE
3.3.1	Initial examination of product	Meets requirements of visual and product drawing.	Dimensional examination IEC 60512-1-1/-2, Test 1a and 1b
3.3.2	Final examination of product	Meets visual requirements.	Visual examination IEC 60512-1-1, Test 1a
<b>ELECTRICAL</b>			
3.3.3	Contact Resistance	Initial:5mΩ Max Final:10mΩ Max	Test current: 1A Measure points see Figure 2. IEC 60512-2-2 Test 2b
3.3.4	Temperature Rise Test	(without standard) ΔT :30°C(UL1059) ΔT :45°C(IEC61984)	Length of test cable: 0.46m up to AWG16 1.22m over AWG14 Carry its rated current Measure points see Figure 2. IEC 60512-5-1 Test 5a
3.3.5	Dielectric Voltage Withstand Test	No flashover or breakdown of voltage Current leakage:0.5mA Max.	Mated specimen Test voltage 3310V AC Duration 1minute. Test between adjacent circuits of mated connectors. IEC60512-4-1 Test 4a
3.3.6	Insulation Resistance	Not less than 100MΩ	Mated specimen Test voltage 500V DC Time:60s Test between adjacent circuits of mated connectors. IEC 60512-3-1 Test 3a Method B
<b>MECHANICAL</b>			
3.3.7	Durability of marking	Marking shall be still readable according to 6.2 of EN61984 (If marking made by impression, molding, pressing or engraving or the like are not subjected to this test)	Test piston: Size 1 Wet test with liquid: water Duration: 10 cycles Force:5N IEC 60068-2-70 Test Xb
3.3.8	Polarization and coding	No damage likely to impair function	Load: 20N IEC 60512-13-5 Test 13e
3.3.9	Pull out force of terminations	No damage likely to impair function	Load: AWG16,1.5SQmm : 40N AWG14,2.5SQmm : 50N AWG12,4SQmm : 60N AWG10: 80N Duration: 1min UL1059/IEC60947-1-7-1

3.3.10	Mechanical strength impact	Connector and internal insulation shall no damage to impair normal use. A reduction of clearance and creepage distance is not allowed.	Dropping height: - 750mm for specimens of mass $\leq$ 250g - 500mm for specimens of mass $>$ 250g Dropping cycles:8 positions in 45° step, one cycles per position IEC 60512-7-2 Test 7b
3.3.11	Mating and Un-mating force of full loaded connector	Mating force: 12.5N Max/position. Un-mating force:1N~12.5N/position.	The specified force shall be applied in axial direction with the speed of 20mm/min. Without Locking parts IEC 60512-13-1 Test 13a
3.3.12	Mechanical Operation (Durability)	100 operation cycles without load No damage likely to impair normal use 6.14.1 of EN 61984	Shall be engaged and disengaged by means of A) a device simulating normal operating conditions at the speed of approximately 50mm/min B) manual mating/un-mating 300 Max. cycle per hour IEC 60512-9-1 Test 9a
3.3.13	Vibration, Random	No damage likely to impair function No discontinuities greater than $t>1\mu\text{s}$	Frequency:5~150Hz Per EN 61373, Category 1, Class B Fixed position of cable:100mm
3.3.14	Vibration, Low Frequency	No damage likely to impair function No discontinuities greater than $t>1\mu\text{s}$	Frequency:10-55Hz/min Amplitude:1.52mm Duration 2hours in each or the three orthogonal axes Fixed position of cable:100mm IEC60512-6-4 Test 6d
3.3.15	Shock	No damage likely to impair function No discontinuities greater than $t>1\mu\text{s}$	Acceleration:500m/s <sup>2</sup> Duration:11ms Total 18 shocks(three positive and three negative in each of the three orthogonal axes) Fixed position of cable:100mm IEC60512-6-3 Test 6c
3.3.16	Housing Locking Strength	No damage likely to impair function	Pull out force:49N Pull to un-mating direction Duration:15s IEC60512-15-6 Test 15f

#### ENVIRONMENTAL

3.3.17	Cold	No damage likely to impair function	Subject mated specimen to -55°C Duration time:2h, Test Ab IEC 60512-11-10 Test 11j (IEC 60068-2-1)
3.3.18	Dry Heat	No damage likely to impair function	Subject mated specimen to +125°C Duration time:250h Test Bb IEC 60512-11-9 Test 11i (IEC 60068-2-2)

3.3.19	Humidity	No damage likely to impair function	Subject mated specimen to Min ambient temperature: 25°C Max ambient temperature: 65°C Humidity:80~95% R.H. Cold shock -10°C performed Number of cycles:10 Duration time:12h+12h Variant 1 EIA364-31 method IV
3.3.20	Rapid Change of temperature (Temperature Cycle)	No damage likely to impair function	Subject mated specimen to $T_a = -55 \pm 2^\circ\text{C}$ to $T_b = +125 \pm 2^\circ\text{C}$ , duration $t_1$ : 1h each extreme, 25 cycles IEC 60512-11-4 Test 11d (IEC 60068-2-14 Test Na)
3.3.21	Corrosion (Alternative)	No damage likely to impair function Per 6.21 of EN 61984	Subject mated specimen Flowing mixed gas corrosion according to test 11g, method 1 or method 4 (Table 1) Duration time: 96h IEC 60512-11-7 Test 11g 7.3.14 of EN 61984
3.3.22	Salt Spray	No damage likely to impair function	Subject mated specimen to $5 \pm 1\%$ salt spray Duration time: 96h IEC 60512-11-6
3.3.23	Solderability	Wet solder coverage 95% Min	Dip depth: 3.2mm Used solder: Lead-free solder Solder temperature: $240 \pm 5^\circ\text{C}$ Immersion time: $3 \pm 0.5\text{s}$ IEC60512-12-1 Test12a
3.3.24	Resistance to Soldering Heat	No damage likely to impair function	Dip in solder bath with PCB Used solder: Lead-free solder Solder temperature: $265 \pm 5^\circ\text{C}$ Immersion time: $10 \pm 1\text{s}$ IEC60512-12-4 Test12d

Figure 1

**NOTE**

Shall meet visual requirements, show no physical damage, and meet requirements of additional tests as specified in the Product Qualification and Requalification Test Sequence shown in Figure 3.

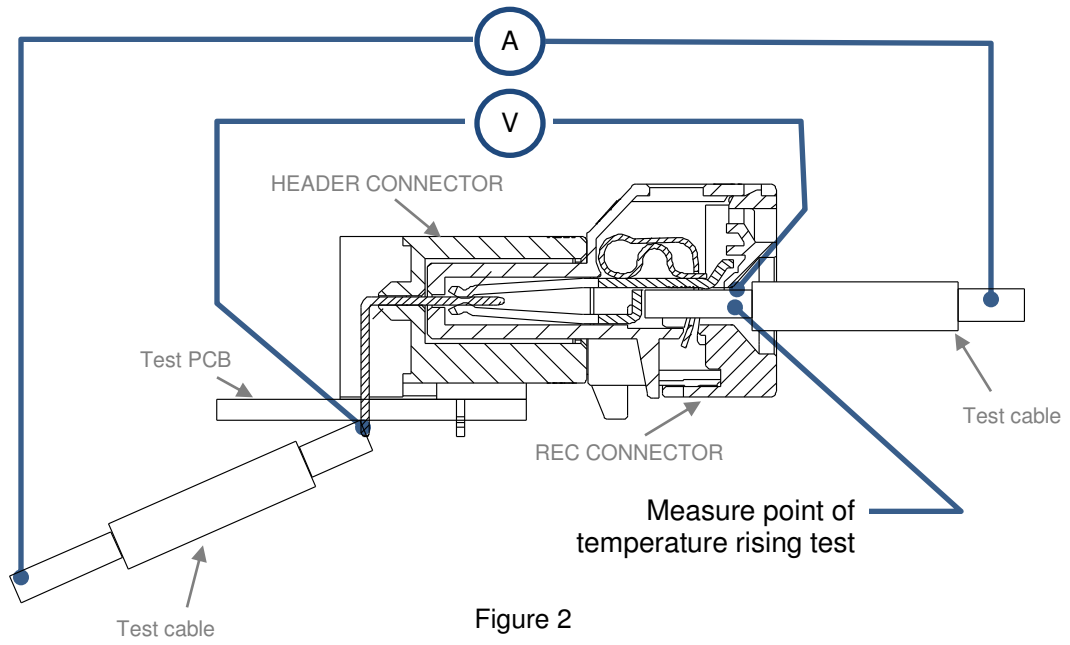

## 3.4. Product Qualification and Requalification Test Sequence

TEST OR EXAMINATION	TEST GROUP												
	1	2	3	4	5	6	7	8	9	10	11	12	
	TEST SEQUENCE (a)												
Initial examination of product	1	1	1	1	1	1	1	1	1	1	1	1	
Contact Resistance				2,6		2,6	2,5	2,5	2,5	2,4			
Temperature Rise Test					2								
Dielectric Voltage Withstand Test						7			6				
Insulation Resistance						8			7				
Durability of marking	2												
Polarization and coding	3												
Pull out force of terminations			2										
Mechanical strength impact		2											
Mating and Un-mating force				3,5									
Mechanical Operation				4									
Vibration, Random								3					
Vibration, Low Frequency							3						
Shock							4	4					
Housing Locking Strength	4												
Cold						3							
Dry Heat						4							
Humidity									3				
Rapid Change of temperature									4				
Corrosion						5							
Salt Spray										3			
Solderability											2		
Resistance to Soldering Heat												2	
Final examination of product	5	3	3	7	3	9	6	6	8	5	3	3	

Figure 3

**NOTE**

(a) Numbers indicate sequence in which tests are performed.