



LUMAWISE Z50 High Performance Light Emitting Diode (LED) Holders

1. SCOPE

1.1. Content

This specification defines performance, tests, and quality requirements for LUMAWISE Z50 high performance LED holders.

1.2. Qualification

When tests are performed on the subject product line, procedures specified in Figure 1 shall be used. All inspections shall be performed using the applicable inspection plan and product drawing.

2. APPLICABLE DOCUMENTS

The following documents form a part of this specification to the extent specified herein. Unless otherwise specified, the latest edition of the document applies. In the event of conflict between the requirements of this specification and the product drawing, the product drawing shall take precedence. In the event of conflict between the requirements of this specification and the referenced documents, this specification shall take precedence.

2.1. TE Documents

- 109-1 General Requirements for Testing
- 114-133019 Application Specification: LUMAWISE Z50 High Performance LED Holders
- 501-19216 Qualification Test Report
- 2213480 Customer Drawing

2.2. Industry Documents

EIA-364, "Electrical Connector/Socket Test Procedures Including Environmental Classifications"

3. REQUIREMENTS

3.1. Design and Construction

Product shall be of the design, construction, and physical dimensions specified on the applicable product drawing.

3.2. Materials

Materials used in the construction of this product shall be as specified on the applicable product drawing.

3.3. Ratings

UL 8754 (file E469276)

- Voltage: 277V AC/DC maximum
- Current: 5 A
- Operating temperature: -40° to 105°C

IEC 60838-2-2

- CoB made of ceramic (PTI > 600): $U_{max} = 350$ V
- CoB made of MCPCB (PTI > 600): $U_{max} = 235$ V
- CoB made of MCPCB (PTI < 600): $U_{max} = 100$ V
- Current: 3 A maximum
- Operating temperature: -40° to 105°C

Temperature rating is representative for the LED holder. Review of maximum temperature limits for accessories (for example reflectors) being used in conjunction with the LED holder may result in a more limited range.

3.4. Performance and Test Description

Product is designed to meet the electrical, mechanical, and environmental performance requirements specified in Figure 1. Unless otherwise specified, all tests shall be performed at ambient environmental conditions.

3.5. Test Requirements and Procedures Summary

Test Description	Requirement	Procedure
Initial Examination of Product	The product shall meet the requirements of related drawings.	Visual, dimensional, and functional inspection according to the quality inspection plan.
Visual Examination of Product	The product shall not have visible marks of damage, break, or defect before and after the execution of the tests.	EIA-364-18B
Electrical		
Low Level Contact Resistance (LLCR)	20 milliohms maximum initial ΔR 20 milliohms maximum	EIA-364-23, Option 1 Open voltage: 20 mV maximum Current 100 mA maximum
Temperature Rise	$\Delta T < 30$ K with $I = 5$ A	EIA 364-70, Method 2 Measure temperature rise at 1 A and increase current in steps of 1 A. After a stabilization period of 1 hour and up to 5 A. The holder with LED is mounted on a cooling device made from a bare aluminum plate with dimensions 80×100×8 mm.
Withstanding Voltage	No creeping discharge. No flashover shall occur. Conditions: the samples shall be exposed for 48 hours to moist air having a relative humidity of 93±5% at a temperature of 25±2°C (77±3.6°C). Following the 48-hour period and while still exposed to moist air, the device shall be subjected to the dielectric withstanding voltage test.	2.0 kV AC for 1 minute with 1-mm thick plastic insulated LED dummy. 1.6 kV AC for 1 minute with FR4 LED dummy having a distance of 1.4 mm from top contour edge of LED to contact pad. Leakage current shall not exceed 0.5 mA. Test between contact and ground plate with dummy LED mated according to UL 8754.
Insulation Resistance	500 mega ohm minimum Construction and base material of applied COB LED can give different results.	EIA 364-21 Voltage: 500 VDC for 1 minute. Test between contact and ground plate.
Mechanical		
Wire Insertion Force	15 N maximum	EIA-364-13, Method A Testing speed at 25 mm/min.
Wire Retention Force	15 N minimum	EIA-364-13, Method A Testing speed at 25 mm/min.

Vibration Test	No electrical discontinuity greater than 1 μ sec shall occur. No physical damage.	EIA 364-28 Vibration frequency: 20-500 Hz, 3.10 G peak
		Vibration direction: 3 mutually perpendicular directions Duration: 15 minutes each
Mechanical Shock	No electrical discontinuity greater than 1 μ sec shall occur. No physical damage.	EIA 364-27, Test Condition H Accelerated velocity: 30 G Half sinusoidal shock pulses. Number of shocks: 3 in each direction applied along 3 mutually perpendicular directions. 18 total shocks
LED Repairability	See Note.	EIA-364-9 Mate and un-mate specimens 3 times. One un-mating and mating cycle: unscrew socket, remove LED, replace LED, and screw down LED. Test is done before any energized use in application.
Wire Insertion Repairability	See Note.	Insert wire, extract wire by turning, insert new wire (same gauge), extract wire by turning, and insert new wire (same gauge) again.
Clamping Force	Individual clamp force: 100 N minimum with screw torque between 0.3 and 0.8 Nm	Refer to Figure 2. Determine fastener type. Measure force generated by pre-described torque value.
Reflector Insertion Force (Z35L and Z45L only)	20N Maximum	EIA 364-13 method A. Max rate of 25.4mm/min Measure force required to insert reflector onto LED holder.
Reflector Retention (Z35L and Z45L only)	10N Minimum	EIA 364-13 method A. Max rate of 25.4mm/min Measure force required to remove reflector from LED holder.
Environmental		
Temperature Life	See Note.	EIA-364-17, Method A, Test Condition 4 Subject mated specimens for 125 hours. Test temperature: 125°C
Thermal Shock	See Note.	EIA-364-32, Test Condition VIII Subject specimens to 25 cycles between -40° and 105°C with 30-minute dwells at temperature extremes and 1-minute transition between temperatures.

Damp Heat Cycling	See Note.	EIA-364-31, Method III Subject specimens to 10 cycles (10 days) between 25° and 65°C at 80 to 100% RH.
-------------------	-----------	---

i **NOTE** Shall meet visual requirements, show no physical damage, and meet requirements of additional tests as specified in the product qualification and re-qualification test sequence given in Figure 3.

Figure 1

Step 1

Place LED in holder or secure holder onto dummy plate using screws tightened at pre-described torque value.

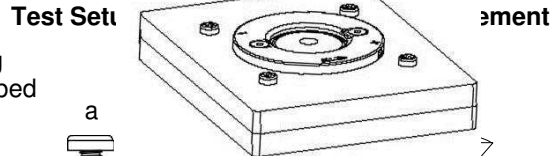

Step 2

Remove lower plate, distant plate and LED or dummy plate.

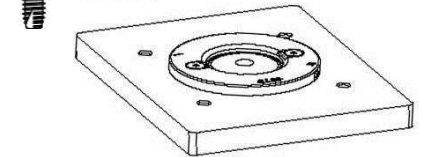

Step 3

Jig and holder ready for test.

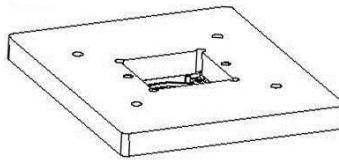

Step 4

Probe push location for force versus torque value test.

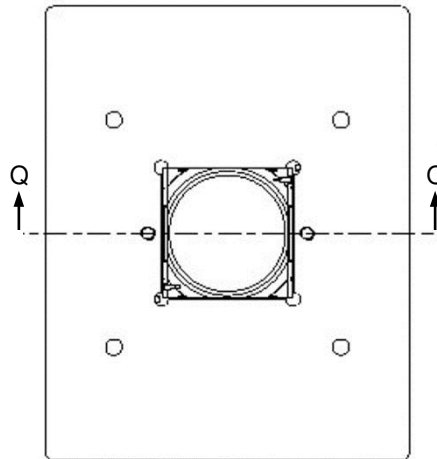
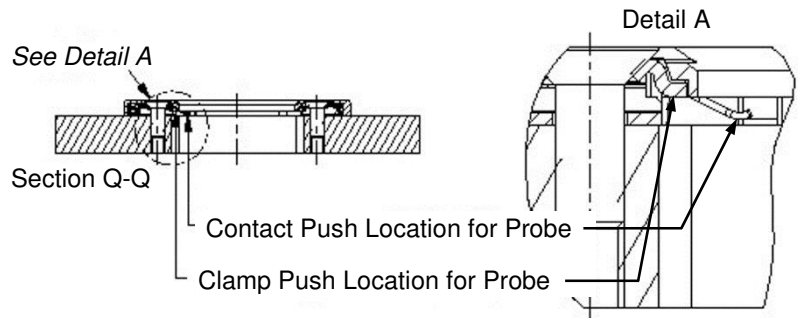

Figure 2

3.6. Product Qualification and Re-Qualification Test Sequence

SAMPLE DESCRIPTION	SAMPLE QUANTITY (Minimum)					
	TEST GROUP (a)					
	A	B	C	D	E	F
Sample Amount	10	10	10	5	18	
20 AWG Solid Wire					6	
20 AWG Stranded Wire, 7 Strands					6	
18 AWG Solid Wire	20	20	20		6	
18 AWG Stranded Wire, 16 Strands					6	
TEST OR EXAMINATION	TEST SEQUENCE (b)					
Visual Examination of Product	1,3,7,9,11	1,3,5,7	1,10	1,3	1,4	1,4
LLCR	2,6		2,4,6,8			
Temperature Rise		6				
Withstanding Voltage		2				
Insulation Resistance		4				
Vibration Test						
Mechanical Shock						
Wire Insertion Force					2	
Wire Retention Force					3	
Reflector Insertion Force (<i>Z50L only</i>)						2
Reflector Retention (<i>Z50L only</i>)						3
LED Repairability	8					
Wire Insertion Repairability	10					
Temperature Life			3			
Thermal Shock			5			
Damp Heat Cycling			7			
Clamping Force				2		

(a) See paragraph 4.1.A.

(b) Numbers indicate sequence in which tests are performed.

Figure 3

4. QUALITY ASSURANCE PROVISIONS

4.1. Qualification Testing

A. Specimen Selection

Specimens shall be selected at random from current production and shall be in accordance with relevant drawings. All samples shall be stored for 1 day at 50% RH.

Applicable wire sizes according to UL 1007 are 20 and 18 AWG. Wire strip length range is 7 to 8 mm.

The holder has 2 LED clamping springs and 2 poke-in contacts. The samples can **only** be mounted **with** LED in holder or dummy plate. The recommended torque for tightening the mounting screws is 0.5 Nm.

B. Test Sequence

Qualification inspection shall be verified by testing specimens as specified in Figure 3.

4.2. Re-Qualification Testing

If changes that significantly affecting form, fit, or function are made to the product or manufacturing process, product assurance shall coordinate re-qualification testing consisting of all or part of the original testing sequence as determined by development/product, quality, and reliability engineering.

4.3. Acceptance

Acceptance is based on verification that the product meets the requirements of Figure 1. Failures attributed to equipment, test setup, or operator deficiencies shall not disqualify the product. If product failure occurs, corrective action shall be taken and specimens re-submitted for qualification. Testing to confirm corrective action is required before re-submittal.

4.4. Quality Conformance Inspection

The applicable quality inspection plan shall specify the sampling acceptable quality level to be used. Dimensional and functional requirements shall be in accordance with the applicable product drawing and this specification.