



Product Specification

USB Type-C Connector

DESIGN OBJECTIVES

The product described in this document has not been fully tested to ensure conformance to the requirements outlined below. Therefore, TE makes no representation or warranty, express or implied, that the product will comply with these requirements. Further, TE may change these requirements based on the results of additional testing and evaluation. Contact TE Engineering for further details.

1 Scope :

1.1 Contents

This specification covers the requirements for product performance, test methods and quality assurance provisions of TE Connectivity USB type C connector.

Applicable product description and part numbers are as shown in Appendix 1.

2. Applicable Documents:

The following documents form a part of this specification to the extent specified herein. In the event of conflict between the requirements of this specification and the product drawing, the product drawing shall take precedence. In the event of conflict between the requirements of this specification and the referenced documents, this specification shall take precedence.

2.1 TE Connectivity Specification:

- A. 109-1: Test Specification, General Requirements for Testing
- B. 501-115141-2: Qualification Test Report.

2.2 Commercial Standard and Specification:

- A. ANSI/EIA 364-C
- B. Universal Serial Bus Type-C Connector and Cables Assemblies Compliance Document

3. Requirements :

3.1 Design and Construction:

Product shall be of the design, construction and physical dimensions specified on the applicable product drawing.

3.2 Materials:

- A. Contact
Material: Copper alloy
- B. Housing
Thermo Plastic, UL 94 V-0
- C. Shell
Material: Stainless steel

3.3 Ratings :

- A. Voltage Rating: 30V Max.
- B. Current Rating:
 - (1). VBUS /GND pins: 1.25A/Pin Max.
 - (2). SBU1/SBU2: 1.0A/Pin Max.
 - (3). Signal pins contact: 0.25A Min.
- C. Operation Temperature: -40°C to 85°C



3.4 Performance Requirements and Test Descriptions:

The product shall be designed to meet the electrical, mechanical and environmental performance requirements specified in Fig.1. All tests shall be performed in the room temperature, unless otherwise specified.

Temperature: 15°C ~ 35°C

Humidity :25% ~ 85% R.H.

3.5 Test Requirements and Procedures Summary

Table.1

Test Item	Procedures	Requirements
Visual Inspection	EIA 364-18B	Visual inspection samples shall be free from defect such as damage, deformation, blister and burrs that are detrimental to the function and appearance.
Electrical		
Low Level Contact Resistance	EIA 364-23 The low level contact resistance (LLCR) measurement is made across the plug and receptacle mated contacts and does not include any internal paddle cards or substrates of the plug or receptacle. See Figure 1 Measure at 20mV (max) open circuit at 100 mA	40 mΩ (Max) initial for VBUS, GND and all other contacts. 50 mΩ Maximum after initial measurement.
Continuity	See USB Type C Compliance Document Appendix E.	No discontinuities or shorts allowed.
Dielectric Withstanding Voltage	EIA-364-20, Method B. Applicable to both receptacle and plug. 100VAC (rms) for 1 minute at sea level.	No break down shall occur when voltage is applied between adjacent contacts of unmated and mated connectors
Insulation Resistance	EIA 364-21 Applicable to both receptacle and plug. Apply 500V DC Apply the above specified voltage between adjacent contacts for 1 minute.	>100 MΩ insulation resistance between adjacent contacts of unmated and mated connectors
Current Rating	EIA 364-70, Method 2. See USB Type C Compliancy Document Appendix C. A current of 5.0 A shall be applied collectively to VBUS pins (i.e., pins A4, A9, B4, and B9) and 1.25 A applied to the SBU1/SBU2 pin (i.e., A8/B8 of the plug connector) with the return path through the corresponding GND pins (i.e., pins A1, A12, B1, and B12). A minimum current of 0.25 A shall also be applied individually to all the other contacts. Allow to stabilize. Note: special T-rise test boards design per the guidelines in Appendix C of the USB Type C Compliancy Document are to be used.	Temperature rise of the outside shell surface of the mated connector pair above the VBUS and GND contacts shall not exceed 30°C above ambient temperature.

Table.1 (Cont.)

Test Item	Procedures	Requirements
Mechanical		
Insertion Force	EIA-364-13 Maximum rate 12.5mm/min	Between 5N and 20N
Extraction Force	EIA-364-13 Maximum rate 12.5mm/min	Initial: 8 N to 20 N; After test: 6 N to 20 N
Durability	EIA 364-09 10,000 cycles	No evidence of physical damage



Product Design Objective

108-115129-2

Durability (Preconditioning)	EIA 364-09 50 cycles	No evidence of physical damage
Reseating	Manually unplug/plug the connector. Perform 3 such cycles	No evidence of physical damage
4-Axis Continuity Test	See USB Type C Compliancy Document Appendix D for detailed test fixtures and procedures. Plug and Receptacle: Subject the mating interface to the moments defined in USB Type C Compliancy Document Appendix D for at least 10 seconds.	No discontinuities greater than 1 microsecond duration in any of the four orientations tested.

Table.1 (End.)

Test Item	Procedures	Requirements
Environmental		
Temperature Life	EIA-364-17, Method A 105°C without applied voltage for 120hrs	Low level contact resistance meets spec before and after the Temperature Life test.
Temperature Life (Preconditioning)	EIA-364-17, Method A 105°C, 72hrs	Low level contact resistance meets spec before and after the Temperature Life test.
Thermal Shock	EIA-364-32, Method A, Condition I, duration A-4 (-55°-+85°C, 10 cycles)	No evidence of any physical damage. Low level contact resistance meets spec before and after the Thermal Shock test.
Cyclic Temperature and Humidity	EIA-364-31, Method III, w/o optional cold shock and vibration. Exceptions per EIA-364-1000: - Cycle between 25°C/80%RH and 65°C/50%RH. - Ramp 0.5hr, dwell 1hr, dwell starts when conditions are stabilized. - 24 cycles total - Allowable variation $\pm 3^{\circ}\text{C}$ and $\pm 3\% \text{RH}$	No evidence of any physical damage. Low level contact resistance meets spec before and after the Thermal Shock test.
Vibration	EIA-364-28, Condition VII-D, 15min in each of 3 mutually perpendicular directions. Both mating halves should be fixed rigidly. (Power Spectral Density $0.02\text{g}^2/\text{Hz}$, Overall rms 3.10g)	No evidence of physical damages and no discontinuity longer than 1 microsecond.
Mixed Flowing Gas	EIA-364-65, class IIA, 112hrs unmated, 56hrs mated (168hrs total).	No evidence of any physical damage. Low level contact resistance meets spec before and after the Thermal Shock test.
Thermal Disturbance	Cycle the mated connector pair 10 times between 15°C and 85°C. - ramp $> 2^{\circ}\text{C}/\text{min}$ - dwell > 5 mins (ensure contacts reach temperature) - Humidity not controlled	Low level contact resistance meets spec before and after the test.
Other		
Solderability	Category 3 Steam Age RMA Class 1 flux immerse in molten solder at a temperature of $+255^{\circ}\text{C} \pm 5^{\circ}\text{C}$ at rate of $25.4 \text{ mm} \pm 6.35 \text{ mm}$ per second. Hold in solder for $5 +0/-0.5$ seconds. To include solder pins and mounting pads.	Solderable area shall have a minimum of 95% solder coverage.
Water Ingression (selective for different P/N)	IEC 60529 – IPX8	1.5m/30 minutes, No water is allowed to enter the enclosure. Use water contact detection paper or color liquid.

NOTE: (1) Shall meet visual requirements, show no physical damage, and meet requirements of additional tests as specified in the Product Qualification and Prequalification Test Sequence shown in table 2.



3.6 Product Qualification Test Sequence

Table.2

Test	A-1	A-2	A-3	A-4	A-7	B-1	B-6	C-1 ¹	C-2 ²
Visual Inspection	1,8	1,10	1,8	1,12	1,13	1,3	1,3	1,3	1,3
Low Level Contact Resistance	2,5,7	2,5,7,9	2,5,7	2,5,7,9,11	3,10				
Dielectric Withstanding Voltage					2,11				
Insulation Resistance					12				
Durability					7				
Durability (Preconditioning)	3	3	3	3					
Insertion Force					5,8				
Extraction Force					6,9				
Temperature Life	4			4					
Temperature Life (Preconditioning)			4						
Reseating	6	8		10	4				
Thermal Shock		4							
Cyclic Temperature and Humidity		6							
Vibration			6						
Mixed Flowing Gas				6					
Thermal Disturbance				8					
Current Rating							2		
4-Axis Continuity Test						2			
Solderability								2	
Water Ingression ²									2

Test Requirements and Test Sequence as per USB Type C Compliance Document.

¹ Additional test, not part of USB Type C Compliance Requirements

² Additional test, selection item for water proof product.

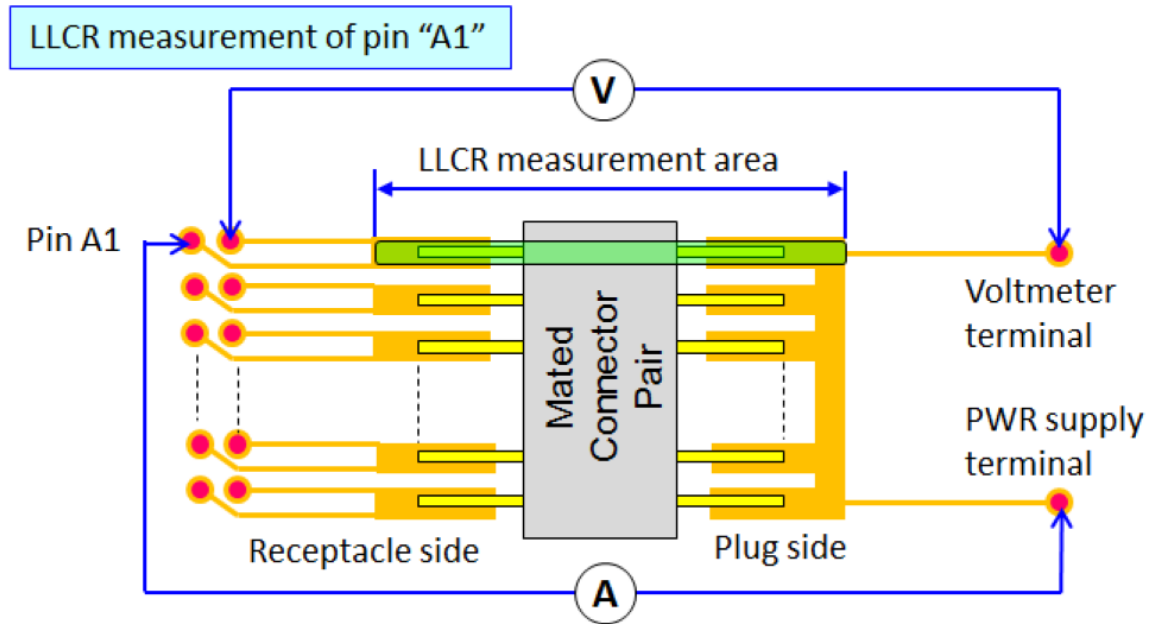

Figure 1: Typical Contact Resistance Measurement

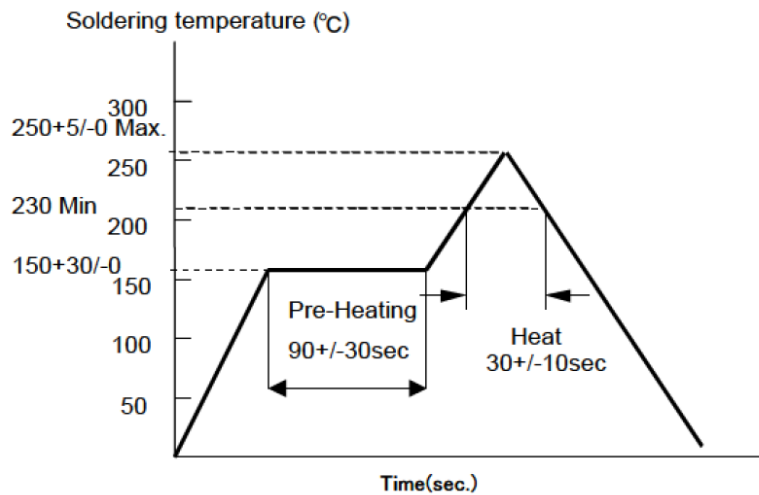

Figure 2. Recommended reflow temp profile

The applicable product descriptions and part numbers are as shown in Appendix.1.

Product Part No.	Description	Notes
2305018-2	USB type-c receptacle Dual Row SMT, on Board	IPX8
1-2305018-2	USB type-c receptacle Dual Row SMT, on Board	NONE WATER PROOF

Appendix.1



Product Design Objective

108-115129-2

(Prepared by) Soldier Zhang

Date
08-Aug-2017

(Checked by) Hapye Wu

Date
08-Aug -2017

(Approved by) Simon Li

Date
08-Aug -2017

LTR	REVISION RECORD	ECN	DR	CHK	APP	DATE
A	RELEASE	-	S.ZH	H.W	S.L	08-Aug-2017