Industrial Mini I/O By-Pass Connector

The product described in this document has not been fully tested to ensure conformance to the requirements outlined below. Therefore, Tyco Electronics Shanghai CO., Ltd. makes no representation or warranty, express or implied, that the product will comply with these requirements. Further, Tyco Electronics Shanghai CO., Ltd. may change these requirements based on the results of additional testing and evaluation. Contact Tyco Electronics Engineering for further details. In case when “product specification” is referred to in this document, it should be read as “design objectives” for all times as applicable.

1. Scope**1.1 Contents**

This specification covers the requirements for product performance, test methods and quality assurance provisions of Industrial Mini I/O By-Pass Connector.

Applicable product description and part numbers are as shown in Appendix 1.

2. Applicable Documents

The following documents form a part of this specification to the extent specified herein. In the event of conflict between the requirements of this specification and the product drawing, the product drawing shall take precedence. In the event of conflict between the requirements of this specification and the referenced documents, this specification shall take precedence.

2.1 TE Specifications

501-106021: Qualification Test Report

2.2 Commercial Standards and Specifications

EIA364 series

3. Requirements**3.1 Design and Construction**

Product shall be of the design, construction and physical dimensions specified on the applicable product drawing.

3.2 Materials

A. Contact:

(1) Plug :

Material: Copper alloy

Finish: Nickel plating all over

Contact area: Au plating

(2) Receptacle :

- Material: Copper alloy
- Finish: Nickel plating all over
- Contact area: Au plating
- Soldering area: Au flash plating

B. Housing:

(1) Plug:

- Material: Thermo plastic
- Flammability: UL 94V-0

(2) Receptacle:

- Material: Thermo plastic
- Flammability: UL 94V-0

C. Shell :

(1) Receptacle:

- Material: Copper alloy
- Finish: Tin plating

3.3 Ratings

- A. Voltage Rating: 30V AC (r.m.s)
- B. Current Rating: 0.5A
- C. Temperature Operating: -40 to 85°C

3.4 Performance Requirements and Test Descriptions:

The product shall be designed to meet the electrical, mechanical and environmental performance requirements specified in Fig.1.

All tests shall be performed in the room temperature, unless otherwise specified.

3.5 Test Requirements and Procedures Summary

Para.	Test Items	Requirements	Procedures
3.5.1	Examination of Product	Meets requirements of product drawing.	Visual inspection No physical damage
Electrical Requirements			
3.5.2	Termination Resistance (Low Level)	80 mΩ Max(Initial). 100 mΩ Max(After test).	Subject mated contacts assembled in housing to 20 mV Max open circuit at 100 mA Max closed circuit. Fig. 3. EIA364-23
3.5.3	Dielectric withstanding Voltage	No creeping discharge nor flashover shall occur. Current leakage: 0.5 mA Max.	250V AC. 1 minute hold. Test between adjacent circuits of mated samples. EIA364-20
3.5.4	Insulation Resistance	500 MΩ Min.	100V DC. 1 minute hold. Test between adjacent circuits of mated samples.

			EIA364-21
3.5.5	Temperature Rising	30 °C Max. under loaded rating current.	Measure temperature rising by energized current.
Mechanical Requirements			
3.5.6	Connector Mating Force	30 N Max.	Cut the protruded locking feature. Operation Speed: 10mm/min. Measure the force required to mate samples. EIA364-13 Fig.4
3.5.7	Connector Unmating Force	30 N Max.	Cut the protruded locking feature. Operation speed: 10mm/min. Measure force necessary to unmate samples. EIA364-13 Fig.4
3.5.8	Durability (Repeated Mate/Unmating)	Termination Resistance (Low Level).	Operation Speed :200cycles/hour No. of Cycles: 5cycles. EIA364-09
3.5.9	Lock Strength	15 N Min. for initial mating. 12 N Min. for 5 th mating.	Mate connector and make lock mechanism effective. Apply axial load to plug connector to unmate the sample. Speed: 10mm/min Fig.4
		5 N Min. for initial and 5 th mating when mated with PN: 2294417-1	
3.5.10	Physical Shock	No electrical discontinuity greater than 1 μsec shall occur. Termination Resistance (Low Level).	Accelerated Velocity : 30G Waveform : Half-sin wave Duration : 11 m sec. Number of drops : 3 drops each to normal and reversed directions of X, Y and Z axes, totally 18 drops. EIA364-27
3.5.11	Vibration (Low Frequency)	No electrical discontinuity greater than 1μsec shall occur. Termination Resistance (Low Level).	Subject mated connectors to 10-55-10 Hz traversed in 1 minute at 1.52mm amplitude 2 hours each of 3 mutually perpendicular planes. EIA364-28
3.5.12	Fixed Strength to PC-Board	No destruction on Receptacle connector with PC-Board and no harmful damage on other parts.	Mate connector. Apply load to edge of plug connector. Load one direction on one sample. 40 N. 1 minute. Fig.5
Environmental Requirements			
3.5.13	Temperature Life (Heat Aging)	Termination resistance (Low Level)	Mated connector 85°C, 315 Hours EIA364-17

3.5.14	Humidity (Steady State)	Insulation resistance Dielectric Strength Termination resistance (Low Level)	Mated connector 90-95%R.H. 40°C 240 hours EIA364-31
3.5.15	Thermal Shock	Termination Resistance (Low Level)	Mated connector -55°C/ 30 min. +85°C/ 30 min. Making this a cycle, repeat 10 cycles. EIA364-32
3.5.16	Humidity-Temperature Cycling	Insulation resistance Dielectric Strength Termination resistance (Low Level)	Mated connector, 25~65°C, 80~100%R.H. 7 cycles Cold shock -10°C performed EIA364-31
3.5.17	Salt Spray	Termination resistance(Low Level) After it is left for 1 hour under a steady temperature/humidity, it is measured.	Mated connector Salt concentration: 5%,35±2°C,48 hours EIA364-26 (MIL-STD-202F Method 101 Condition B)
3.5.18	Hydrogen sulfide Gas (H2S)	Termination resistance (Low Level)	Mated connector H2S Gas :3±1ppm, 40±2°C, 96 hours JEIDA-38

Fig. 1(end)

4 . Product Qualification Test Sequence

Test Examination	Test Group													
	1	2	3	4	5	6	7	8	9	10	11	12	13	14*
	Test Sequence (a)													
Examination of Product	1	1	1	1	1	1	1	1	1	1	1	1	1	1
Termination Resistance (Low Level)				2,6			2,5	2,4	2,4	2,4	2,4	2,4	2,4	
Insulation Resistance	2,5	2,5												
Dielectric withstanding Voltage	3,6	3,6												
Temperature Rising			2											
Conn. Mating Force				3										
Conn. Unmating Force				4										
Durability (Repeated Mate/Unmating)				5										
Lock Strength					2									2

Fixed strength to PC-Board						2							
Vibration (High Frequency)							3						
Physical Shock							4						
Temperature Life (Heat Aging)								3					
Humidity (Steady State)	4								3				
Thermal Shock									3				3
Humidity-Temperature Cycling		4								3			
Salt Spray											3		
Hydrogen sulfide Gas (H2S)												3	

- (a) Numbers indicate sequence in which tests are performed.
- (b) *Test Group 14 only applicable to Product Part No. 2371136-3.

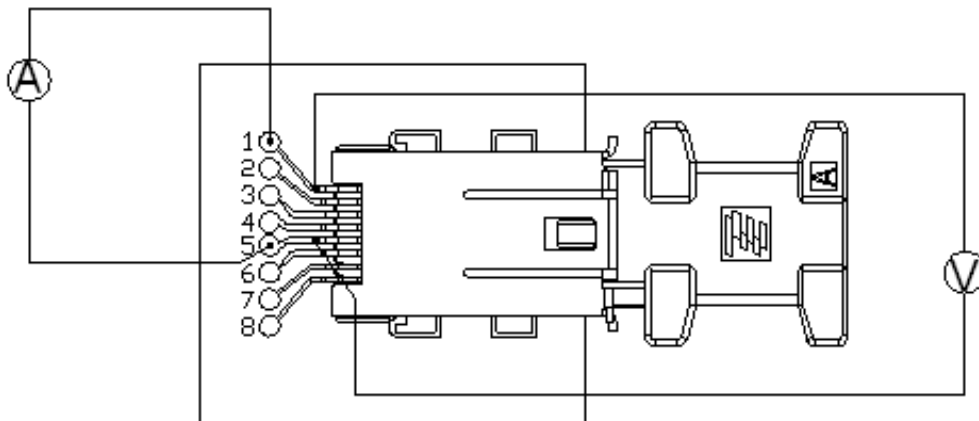

(Measure at conducted circuit : 1-5, 2-4, 3-6.)

Fig.3 Termination Resistance Measurement Points

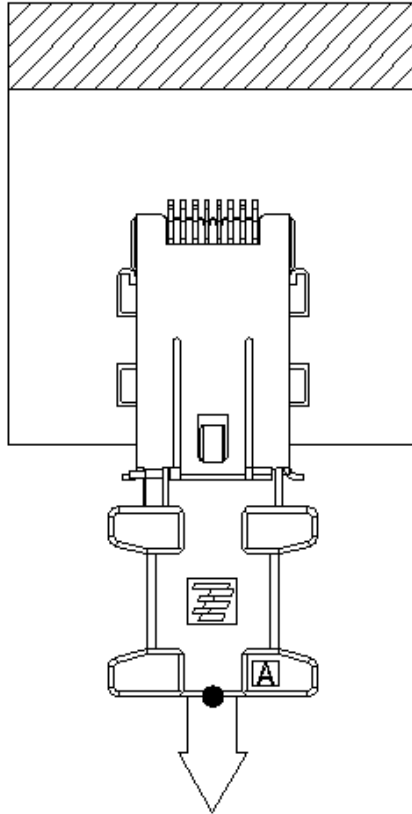
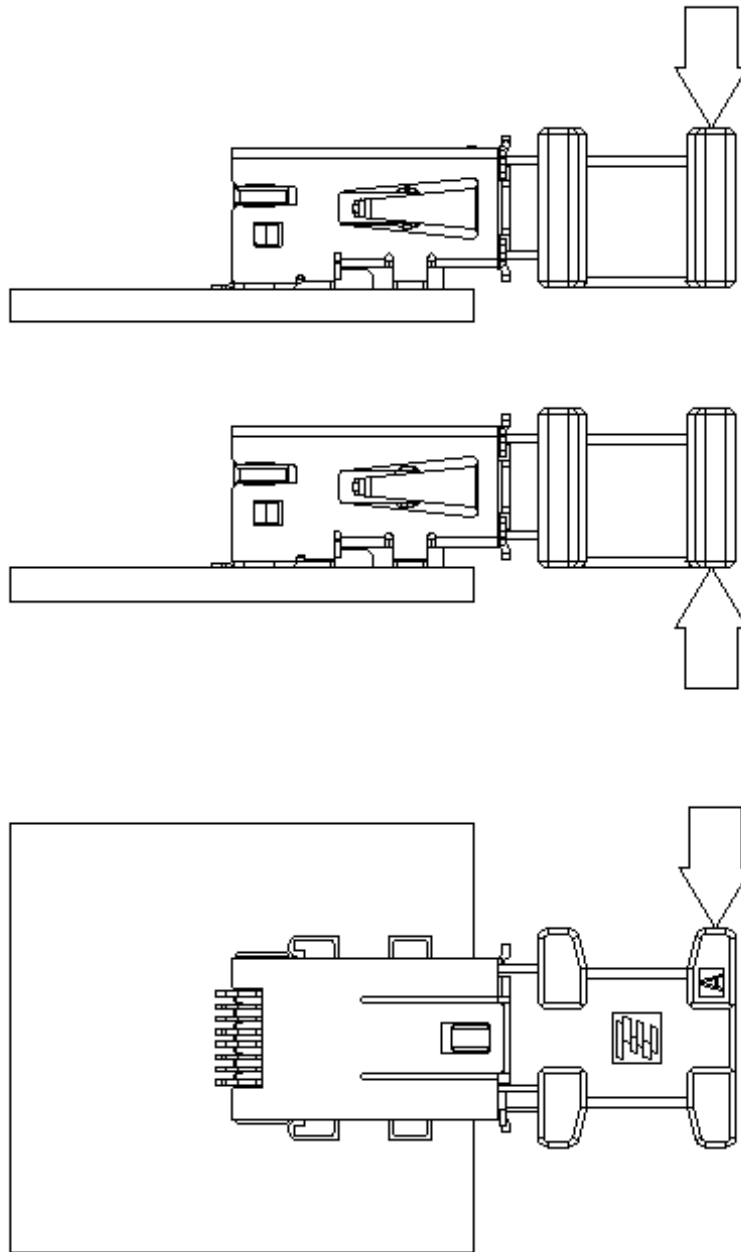

Fig.4 **Mating/ Unmating** Measurement Method



(Fix P.C.Board. Load as shown figure, 1 direction par 1 sample.)

Fig. 5 Fixed strength to PC-Board Measurement Points

The applicable product descriptions and part numbers are as shown in Appendix. 1.

Product Part No.	Description
1981080-1	INDUSTRIAL MINI I/O CONN. 1.27mm PITCH 8P HEADER ASSY D-SHAPE TYPE 1
1971153-1	INDUSTRIAL MINI I/O BY-PASS CONNECTOR Package refer to FGPI-1971153-1, 1pc per small bag, 200pcs per big bag
1971153-2	INDUSTRIAL MINI I/O BY-PASS CONNECTOR Package refer to FGPI-1971153-2, 20pc per small bag, 200pcs per big bag
2040537-1	INDUSTRIAL MINI I/O H-HDR ASSY DIP 1
2371136-1	INDUSTRIAL MINI I/O BY-PASS CONNECTOR Package refer to FGPI-1971153-1, 1pc per small bag, 200pcs per big bag
2371136-2	INDUSTRIAL MINI I/O BY-PASS CONNECTOR Package refer to FGPI-1971153-2, 20pc per small bag, 200pcs per big bag
2294417-1	INDUSTRIAL MINI I/O HDR TYPE I EMBOSS
2371136-3	INDUSTRIAL MINI I/O BY-PASS CONNECTOR
Appendix 1	

LTR	REVISION RECORD	DR	CHK	APVD	DATE
A	Release	Samuel Sun	Rock Lv	Julian Zhou	27NOV2008
A1	Correct a mistake	Leo Liu	Rock Lv	Julian Zhou	19FEB2009
A2	Correct a mistake	Leo Liu	Rock Lv	Julian Zhou	24FEB2009
A3	Correct a mistake	Leo Liu	Rock Lv	Julian Zhou	13APR2009
A4	Add 1971153-2	Danny Chen	Rock Lv	Daniel Zhu	19DEC2011
A5	Add 2371136-1 & 2371136-2	SS	KT	JDB	25FEB2021
A6	PARA 3.5.9 UPDATED	SS	KT	JDB	23DEC2021
A7	Add 2371136-3 & Test Group 14 Change 3.3.C	KT	KT	JDB	27JAN2022