Connector, Metrimate, Power

1. SCOPE

1.1. Content

This specification covers performance, tests and quality requirements for TE Connectivity (TE) Metrimate connectors. These connectors are designed to meet multi-national requirements where applicable and offer a wide range of uses for electronic and electrical equipment.

1.2. Qualification

When tests are performed on subject product line, procedures specified in 109 Series Test Specifications shall be used. All inspections shall be performed using applicable inspection plan and product drawing.

2. APPLICABLE DOCUMENTS

The following documents form a part of this specification to the extent specified herein. Unless otherwise specified, latest edition of the document applies. In the event of conflict between requirements of this specification and product drawing, product drawing shall take precedence. In the event of conflict between requirements of this specification and referenced documents, this specification shall take precedence.

2.1. TE Documents

- 109-1: General Requirements for Test Specifications
- 109 Series: Test Specifications as indicated in Figure 1
- 108-10033: Product Specification
- 108-10042: Product Specification
- 114-10004: Application Specification
- 501-86-1: Test Report

3. REQUIREMENTS

3.1. Design and Construction

Product shall be of design, construction and physical dimensions specified on applicable product drawing.

3.2. Materials

- Contact:
 - Header: Phosphor bronze, tin or gold duplex plating in contact area, tin-lead plating on solder tails, all over nickel plating
 - Plug: Copper alloy, tin or gold over nickel plating, stainless steel spring
 - Receptacle: Copper alloy, tin or gold over nickel plating, stainless steel spring
- Housing:
 - Header: Thermoplastic, red, 130°C, UL94V-0
 - Receptacle: Thermoplastic, red, 130°C, UL94V-0

3.3. Ratings

- Voltage: 600 volts AC (rms) or 600 volts DC
- Current: See Figure 4 for applicable current carrying capability
- Temperature:
 - -55 to 130°C for gold plating
 - -55 to 90°C for tin plating

3.4. Performance and Test Description

Product is designed to meet electrical, mechanical and environmental performance requirements specified in Figure 1. Unless otherwise specified, all tests shall be performed at ambient environmental conditions per Test Specification 109-1.

3.5. Test Requirements and Procedures Summary

Test Description	Requirement	Procedure
Examination of product.	Meets requirements of product drawing and Application Specification 114-10004.	Visual, dimensional and functional per applicable quality inspection plan.
ELECTRICAL		
Termination resistance.	10 milliohms maximum.	TE Spec 109-6-1. Subject mated contacts assembled in housing to 50 mv maximum open circuit at 100 ma maximum. See Figure 3.
Temperature rise vs current.	30°C maximum temperature rise at specified current.	TE Spec 109-45-1. Measure temperature rise vs current. See Figure 4.
MECHANICAL		
Vibration, random.	No discontinuities of 1 microsecond or longer duration. See Note.	TE Spec 109-21-7. Subject mated samples to 9.79 G's rms between 10-500 Hz. 20 minutes in each of 3 mutually perpendicular planes. See Figure 5.
ENVIRONMENTAL		
Humidity-temperature cycling.	See Note.	TE Spec 109-23-4, Condition B. Subject mated samples to 10 cycles between 25 and 65°C at 95% RH.
Temperature life.	See Note.	TE Spec 109-43. Subject mated samples to temperature life at 130°C for 240 hours for gold plated contacts and 90°C for 240 hours for tin plated contacts.

Figure 1 (continued)

Test Description	Requirement	Procedure
Mixed flowing gas.	See Note.	TE Spec 109-85-2. Subject mated samples to environmental class II for 14 days.

NOTE *Shall meet visual requirements, show no physical damage and shall meet requirements of additional tests as specified in Test Sequence in Figure 2.*

Figure 1 (end)

3.6. Product Qualification and Requalification Test Sequence

Test or Examination	Test Group (a)
	1
Test Sequence (b)	
Examination of product	1,8
Termination resistance	2,6
Temperature rise vs current	7
Vibration	5(c)
Humidity-temperature cycling	3(d)
Temperature life	4
Mixed flowing gas	3(e)

NOTE

- (a) *See paragraph 4.1.A.*
- (b) *Numbers indicate sequence in which tests are performed.*
- (c) *Discontinuities shall not be measured. Energize at 18°C level for 100% loadings per Test Specification 109-151.*
- (d) *Tin plated samples only. Precondition by mating and unmating for 50 cycles.*
- (e) *Gold plated samples only. Precondition by mating and unmating for 500 cycles.*

Figure 2

4. QUALITY ASSURANCE PROVISIONS

4.1. Qualification Testing

A. Sample Selection

Samples shall be prepared in accordance with applicable Instruction Sheets and shall be selected at random from current production. All test groups shall each consist of a minimum of 3 plugs and 3 receptacle connectors from tin and gold plated wire to wire and wire to board product. A minimum of 30 contacts shall be selected and identified, unless otherwise specified, these contacts shall be used for all measurements.

B. Test Sequence

Qualification inspection shall be verified by testing samples as specified in Figure 2.

4.2. Requalification Testing

If changes significantly affecting form, fit or function are made to product or manufacturing process, product assurance shall coordinate requalification testing, consisting of all or part of original testing sequence as determined by development/product, quality and reliability engineering.

4.3. Acceptance

Acceptance is based on verification that product meets requirements of Figure 1. Failures attributed to equipment, test setup or operator deficiencies shall not disqualify product. When product failure occurs, corrective action shall be taken and samples resubmitted for qualification. Testing to confirm corrective action is required before resubmittal.

4.4. Quality Conformance Inspection

The applicable quality inspection plan will specify sampling acceptable quality level to be used. Dimensional and functional requirements shall be in accordance with applicable product drawing and this specification.

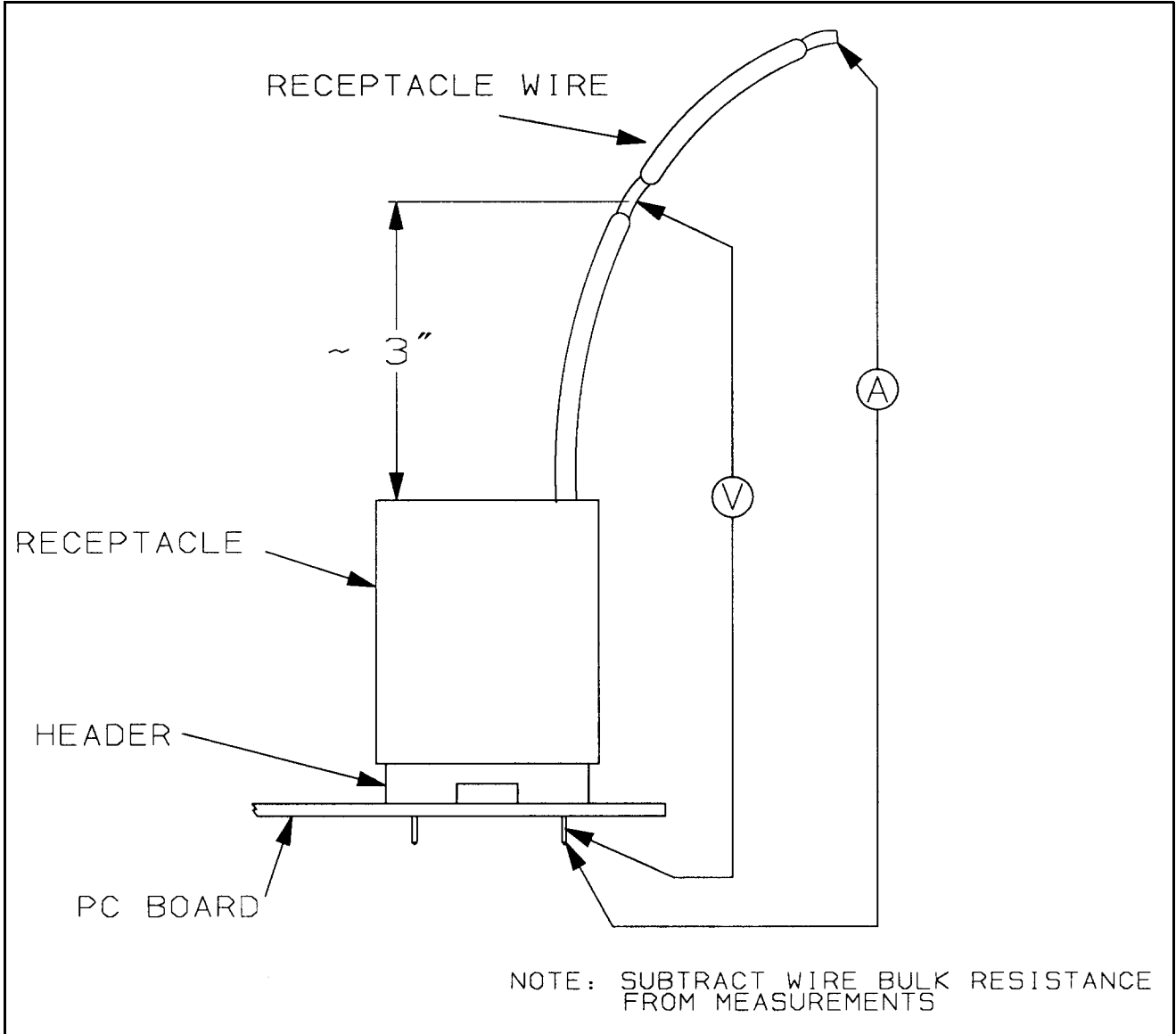

Figure 3A
Termination Resistance Measurement Points
Wire To Board

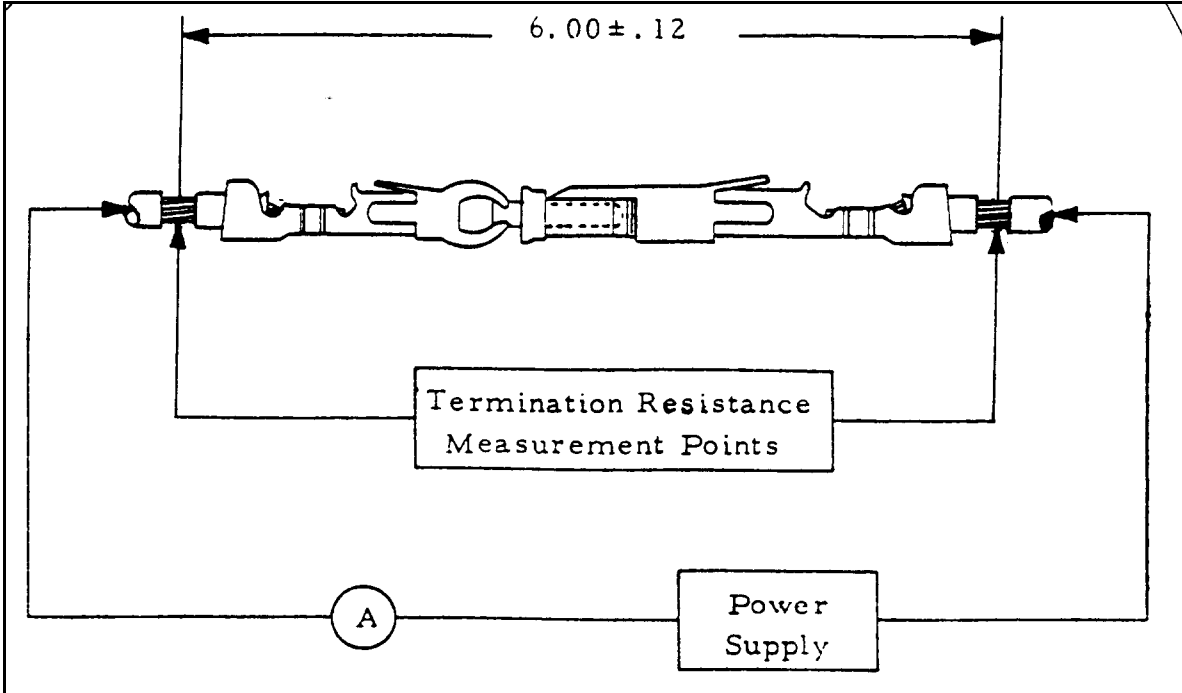

Figure 3B
Termination Resistance Measurement Points
Wire To Wire

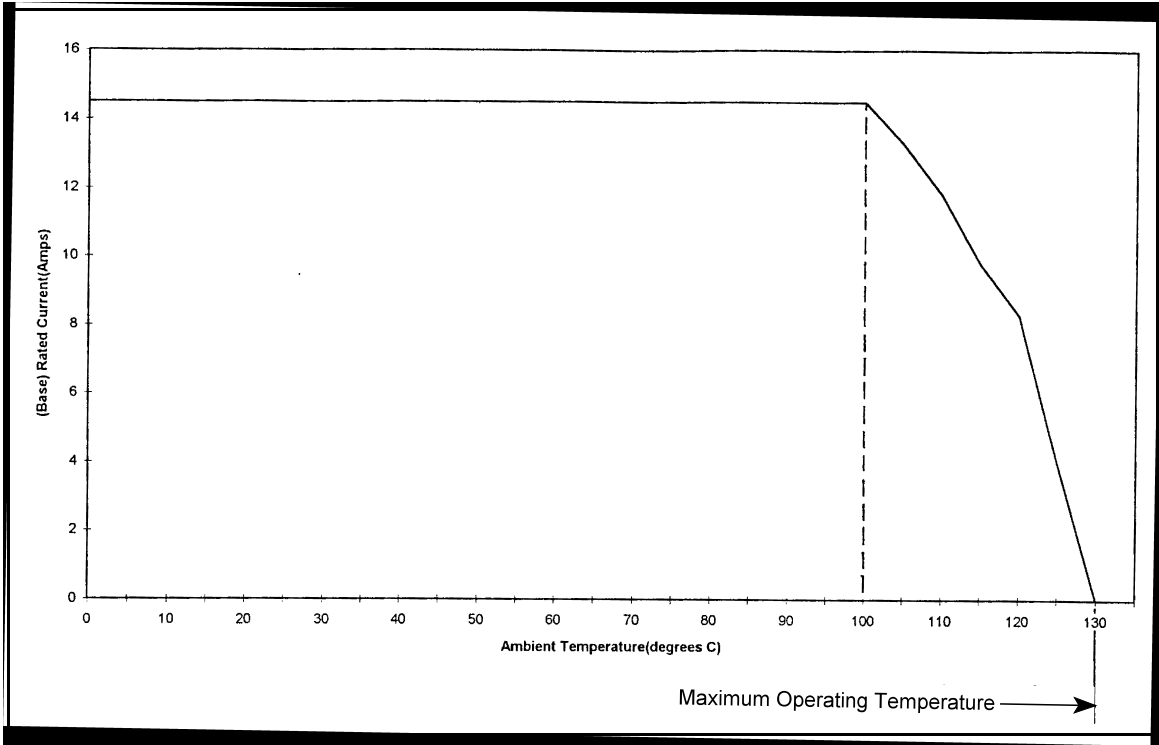

Figure 4A
Current Carrying Capability
Gold Plated Contacts

Percent Connector Loading	Wire Size AWG						
	26	24	22	20	18	16	14
Wire To Board							
Single Contact	.44	.533	.627	.72	.813	.907	1
50	.25	.303	.357	.41	.463	.517	.57
100	.19	.232	.277	.315	.357	.398	.44
Wire To Wire							
Single Contact	.44	.56	.68	.80	.92	1.04	1.16
50	.23	.29	.36	.42	.49	.55	.61
100	.17	.22	.26	.31	.36	.40	.45

NOTE

To determine acceptable current carrying capacity for percentage connector loading and wire gage indicated, use Multiplication Factor (F) from above chart and multiply it times Base Rated Current for a single circuit at maximum ambient operating temperature as shown in Figure 4A.

Figure 4B
Current Rating
Gold Plated Contacts

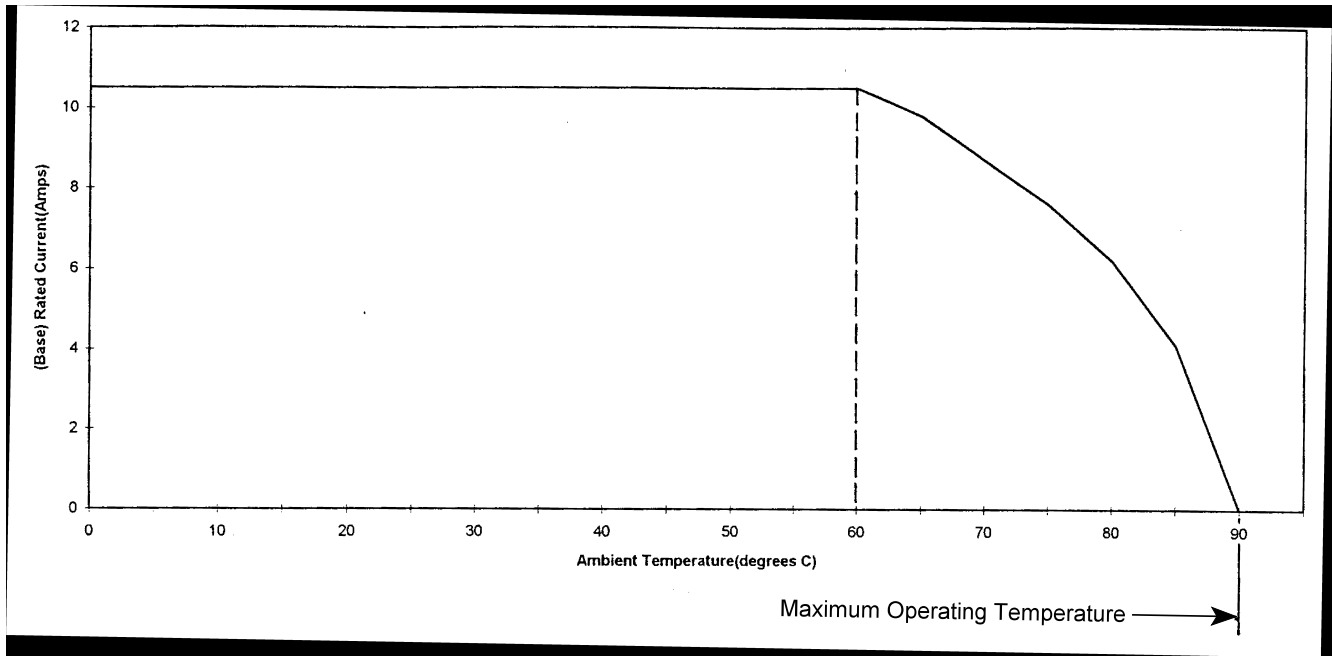

Figure 4C
Current Carrying Capability
Tin Plated Contacts

Percent Connector Loading	Wire Size AWG						
	26	24	22	20	18	16	14
Wire To Board							
Single Contact	.45	.54	.63	.72	.82	.91	1
50	.26	.31	.36	.41	.47	.52	.57
100	.20	.24	.28	.31	.35	.39	.43
Wire To Wire							
Single Contact	.49	.62	.75	.88	1.02	1.15	1.28
50	.26	.32	.39	.47	.54	.61	.68
100	.19	.24	.29	.35	.39	.45	.50

NOTE To determine acceptable current carrying capacity for percentage connector loading and wire gage indicated, use Multiplication Factor (F) from above chart and multiply it times Base Rated Current for a single circuit at maximum ambient operating temperature as shown in Figure 4C.

Figure 4D
Current Rating
Tin Plated Contacts

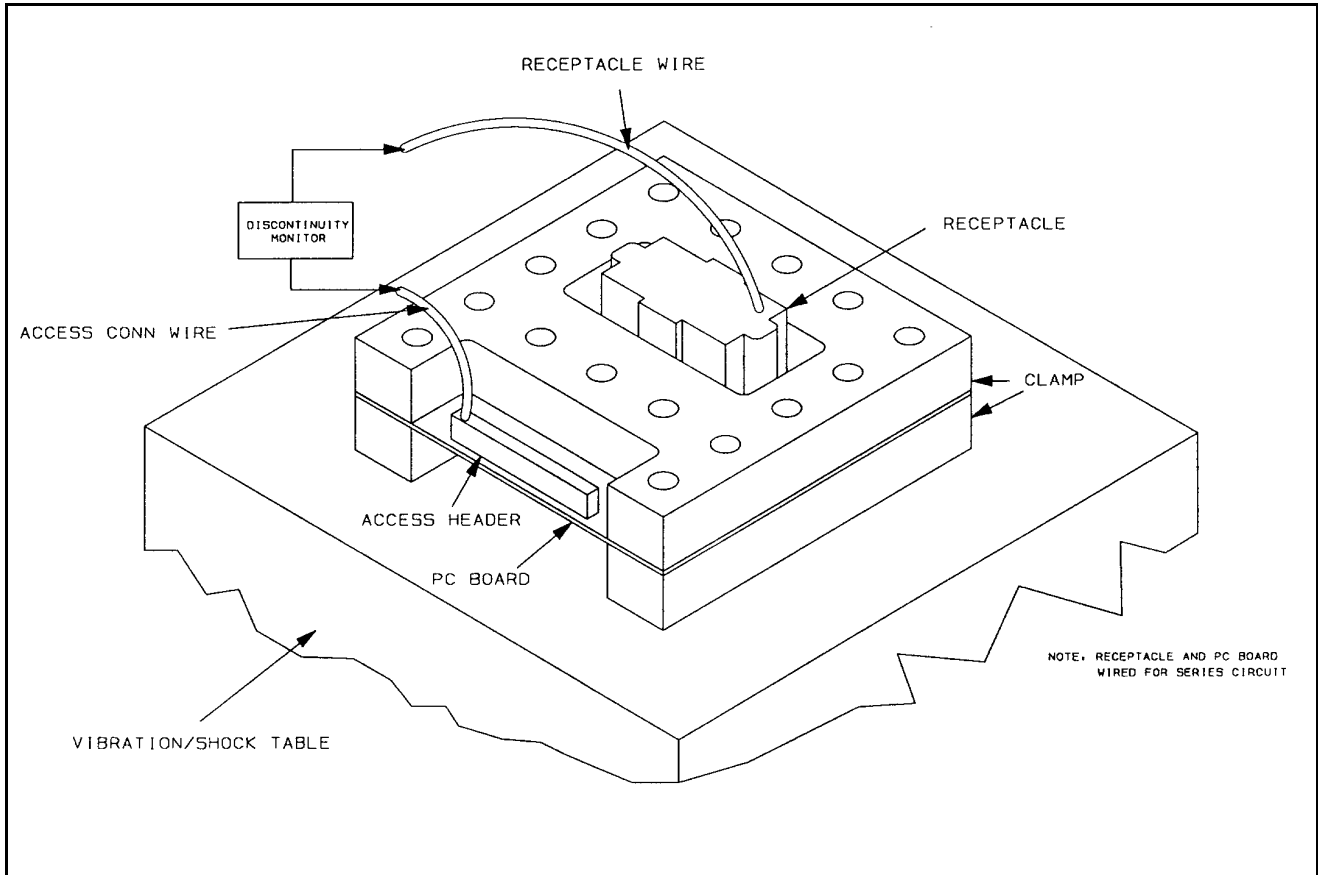

Figure 5A
Vibration Mounting Fixture
Wire To Board

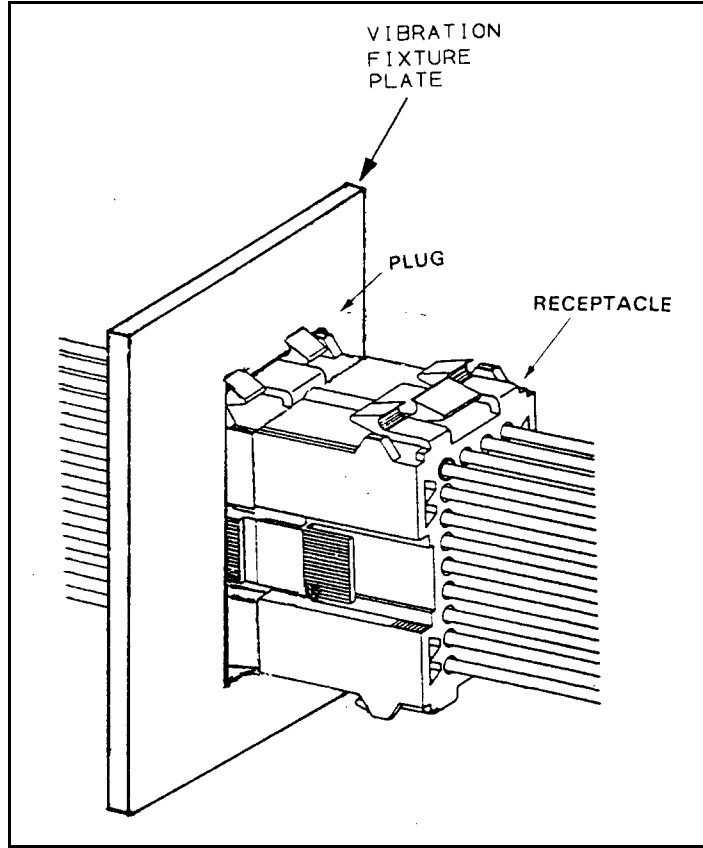

Figure 5B
Vibration Mounting Fixture
Wire To Wire