

PART NUMBER	REV	FIRST USED
466735-1	E	565435-5
466735-3	E	354500-1

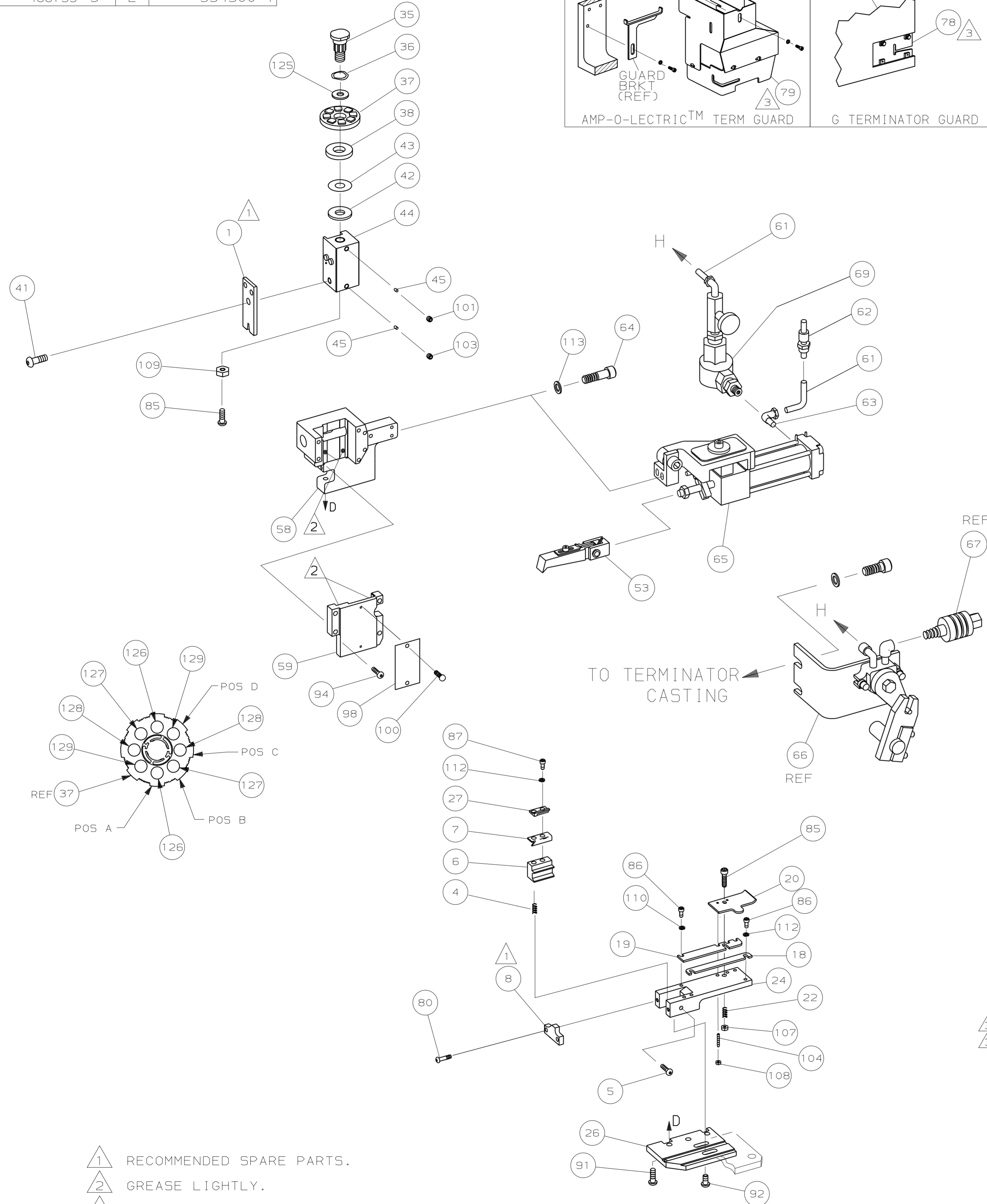
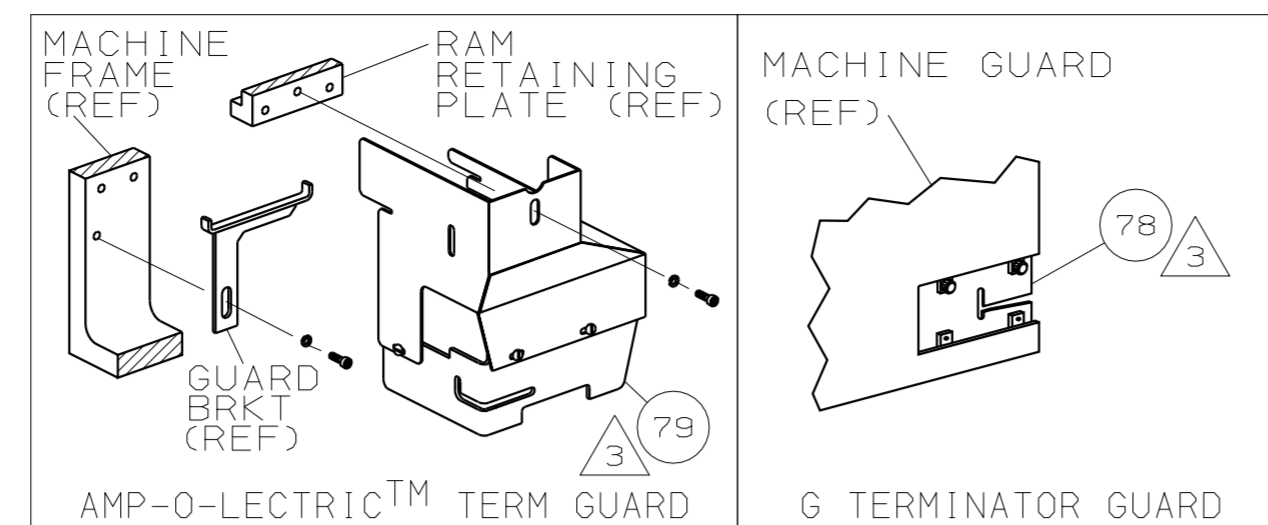

TERMINAL NAME: THRU SPLICE		CRIMPING DATA			
PAD LTR	CRIMP HEIGHT	WIRE SIZE			
A	.101 ±.002 [2.56 ±0.05mm]	8500-10000 CMA			
B	.096 ±.002 [2.44 ±0.05mm]	7000-8500 CMA			
C	.091 ±.002 [2.31 ±0.05mm]	5500-7000 CMA			
D	.085 ±.002 [2.16 ±0.05mm]	4000-5500 CMA			
CRIMP	SIZE	TYPE	RANGE		
WIRE	.180 [4.57mm]	F	4000-10000 CMA		
INSUL	-	-	-		
WIRE STRIP LENGTH	TERM APPL SPEC	FEED	APPL INSTRUCTION	SET UP GAGE	LAYOUT
-	-	.300	408-8039	-	948

QTY	REV	U/M	DWG SIZE	PART NO	DESCRIPTION	ITEM NO
2	2	-	C	1-354779-8	PIN, WIRE DISC (.3080)D	129
2	2	-	C	354779-8	PIN, WIRE DISC (.3030)C	128
2	2	-	C	9-354778-5	PIN, WIRE DISC (.2970)B	127
2	2	-	C	8-354778-5	PIN, WIRE DISC (.2920)A	126
1	1	-	A	986950-1	WASHER, FLAT PRECISION	125
						124
						123
						122
						121
						120
						119
						118
						117
						116
						115
						114
2	2	-	A	21024-5	WASHER, LOCK (NO 10) AIR FD ASSY	113
4	4	-	A	21024-3	WASHER, LOCK (NO 6) STR & SHR	112
						111
2	2	-	A	21899-2	WASHER, FLAT (NO 6) STR GDE	110
1	1	-	A	21019-1	NUT, HEX MACH(1/4-20) RAM	109
2	2	-	A	21018-6	NUT, HEX (8-32) DRAG ADJ SCR	108
1	1	-	A	21022-4	NUT, HEX SL(1/4-20) DRAG STUD	107
						106
						105
2	2	-	A	5-21061-5	SCR, SKT SET CP (8-32x.88) DRAG	104
1	1	-	A	5-21008-4	SCR, SKT SET (10-32x.50) RAM	103
						102
1	1	-	A	21009-2	SCR, SKT SET (1/4-20x.25) RAM	101
2	2	-	A	21017-2	SCR, DRIVE (#2x.19) ID PLATE	100
						99
						98
1	1	-	B	464249-1	PLATE, IDENTIFICATION	98
						97
						96
						95
4	4	-	A	2-21002-9	SCR, BHC (10-32x.75) CAP	94
1	1	-	A	22733-8	SCR, BHC (8-32x.38 LW) ANVIL	93
2	2	-	A	3-21002-3	SCR, BHC (1/4-20x.50) ST GD PL	92
3	3	-	A	2-22733-9	SCR, BHC (1/4-20x.75) H5G	91
						90
						89
						88
2	2	-	A	2-21000-0	SCR, SHC (6-32x.50) STRIP & SHEAR	87
4	4	-	A	1-21002-6	SCR, SHC (6-32x.25) ST GUIDES	86
2	2	-	A	21001-6	SCR, SHC (1/4-20x1.00) DRAG & RAM	85
						84
						83
						82
						81
2	2	-	A	2-21002-3	SCR, BHC (8-32x.63) ANVIL	80
-	1	-	A	460980-1	GUARD ASSY	79
REF	-	-	A	679532-1	INSERT, GUARD	78
						77
						76
						75
						74
						73
						72
						71
QTY	REV	U/M	DWG SIZE	PART NO	DESCRIPTION	ITEM NO

QTY	REV	U/M	DWG SIZE	PART NO	DESCRIPTION	ITEM NO
-1				AMP-0-ELECTRIC	AIRFEED	
-3				BENCH MODEL G	AIRFEED	
-	1	-	C	692655-5	AIR FEED VALVE ASSY	70
-	REF	-	A	24042-2	VALVE, SHUT OFF	67
-	REF	-	C	692655-6	AIR FEED VALVE ASSY	66
1	1	-	B	460277-1	AIR FEED ASSY	65
2	2	-	A	3-21000-9	SCR, SHC 10-32x1.00 AIR ASSY	64
1	-	-	A	22294-6	ELBOW, TUBING 1/8NPT - 1/4 T	63
1	-	-	A	23238-1	QUICK DISCONNECT	62
12.00	12.00	IN	A	27319-4	TUBING, POLY-FLO Ø.25	61
						60
1	1	-	C	458408-1	CAP, RAM	59
1	1	-	D	458414-1	HOUSING	58
						57
						56
						55
						54
1	1	-	B	460680-1	FEED FINGER ASSY	53
						52
						51
						50
						49
						48
						47
						46
2	2	-	A	690191-1	PLUG, NYLON	45
1	1	-	C	458413-1	RAM	44
1	1	-	A	690125-1	WASHER, LAMINATED	43
1	1	-	A	690124-4	WASHER, RAM	42
1	1	-	A	7-21002-9	BOLT, CRIMPER (5/16-24x1.00)	41
						40
						39
1	1	-	A	690223-2	SPACER, INSULATION DISC	38
1	1	-	D	354777-1	WIRE DISC, PLASTIC	37
1	1	-	A	22480-5	WASHER, SPRING	36
1	1	-	B	690212-1	POST, RAM	35
						34
						33
						32
						31
						30
						29
						28
1	1	-	A	458405-1	STRIPPER, REAR	27
1	1	-	D	458411-1	PLATE, BASE	26
						25
1	1	-	B	458412-1	PLATE, STRIP GUIDE	24
						23
1	1	-	A	3-22283-0	SPRING, DRAG	22
						21
1	1	-	A	458403-1	DRAG, STOCK	20
1	1	-	B	458406-1	GUIDE, STRIP (REAR)	19
1	1	-	C	458404-1	GUIDE, STRIP (FRONT)	18
						17
						16
						15
						14
						13
						12
						11
						10
						9
1	1	-	D	458407-9	ANVIL	8
1	1	-	B	458410-1	SHEAR	7
1	1	-	B	458409-1	HOLDER, SHEAR	6
1	1	-	A	690461-4	SCREW, SHEAR STOP	5
1	1	-	A	6-22282-8	SPRING, SHEAR RETURN	4
						3
						2
1	1	-	C	456412-4	CRIMPER, WIRE	1
QTY	REV	U/M	DWG SIZE	PART NO	DESCRIPTION	ITEM NO

- 1 RECOMMENDED SPARE PARTS.
- 2 GREASE LIGHTLY.
- 3 GUARD MUST BE IN PLACE WHEN OPERATING APPLICATOR IN A BENCH MACHINE.
- 4 SEE DRAWING FOR COMPONENTS

LOC A	AMP 3308 REV 3-92	02 JAN 1997	14:57:25	AMP07567	7	6	5	4	3	2	1
DIST 66	DIMENSIONS IN INCHES. DO NOT SCALE PRINT. TOLERANCES UNLESS OTHERWISE SPECIFIED: 2 PLC DEC ±.25 3 PLC DEC ±. 4 PLC DEC ±. ANGLES ± - SURF TEXTURE: ✓ REMOVE BURRS, BREAK SHARP EDGES R.015 MAX										
DR J.BAKER 3/7/95 CHK 3/16/95 C.ERISMAN NAME SCALE -		APP 3/16/95 A.BEDDICK REL 3/28/95 B.MORGAN MACHINE REF MINI APPL		AMP Incorporated Harrisburg, PA 17105-3608		SHEET 1 OF 1 REV E		TB 12-96 CE 5/95 CE -3-95 APP DATE		REVISION RECORD E 0150-7443-96 D 0150-6144-95 EC 0150-5948-95	