

PART NUMBER	REV	FIRST USED
466361-1	H	565435-5

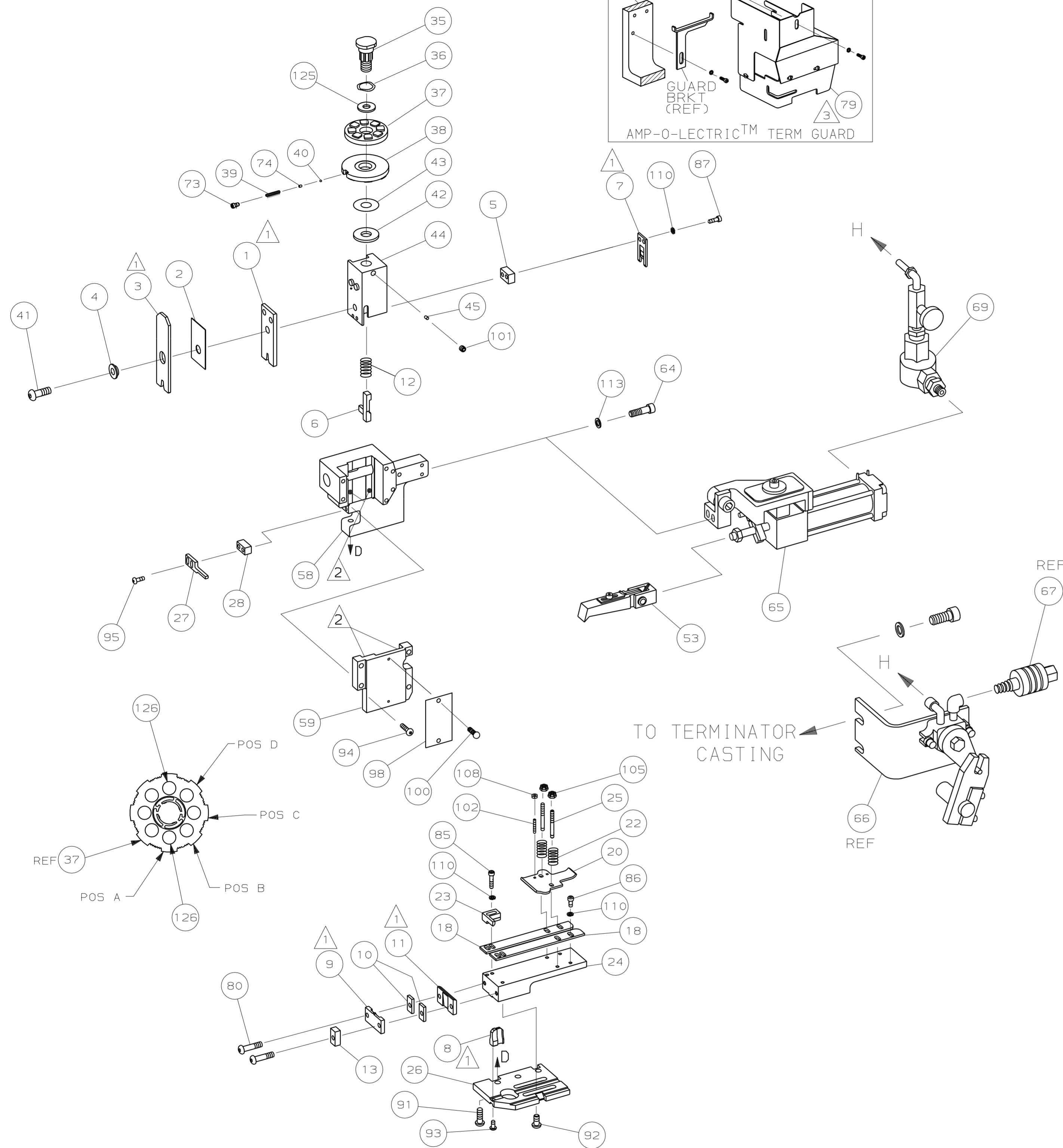
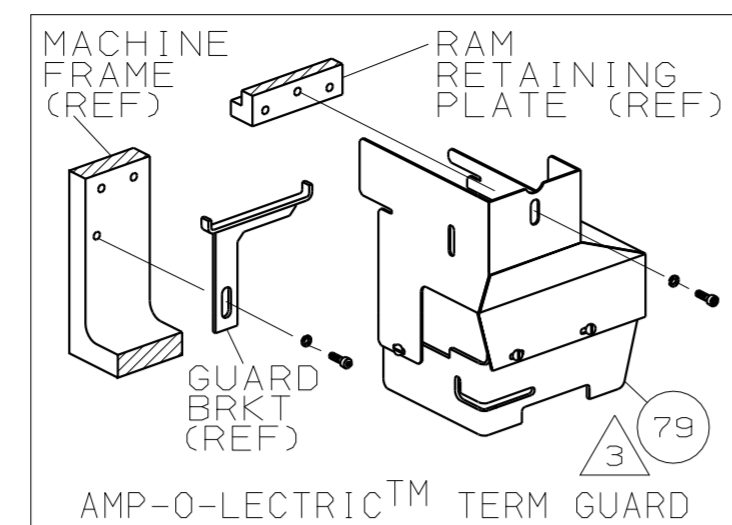

- ① RECOMMENDED SPARE PARTS.
- ② GREASE LIGHTLY.
- ③ GUARD MUST BE IN PLACE WHEN OPERATING APPLICATOR IN A BENCH MACHINE.
- ④ SEE DRAWING FOR COMPONENTS

TERMINAL NAME: .110 FASTON™ RECEPTACLE		CRIMPING DATA	
WIRE STRIP LENGTH	TERM APPL SPEC	FEED	APPL INSTRUCTION
-	114-35000	.665	408-8039
		SET UP GAGE	LAYOUT
		458638-1	808

QTY	REV	MODEL	DESCRIPTION	ITEM NO
1	-	C	7-354779-6 PIN, WIRE DISC (.3370)A	129
1	-	A	986950-1 WASHER, FLAT PRECISION	128
1	-	A	217238-1 GENERAL INSTRUCTION PACKAGE	127
1	-	-	4088039 EF APPL INST 408-8039	126
2	-	A	21024-5 WASHER, LOCK (#10) AIR ASSY	125
7	-	A	21024-4 WASHER, LOCK (NO.8) SHEAR BL	124
2	-	A	21018-4 NUT, HEX (4-40) DRAG	123
2	-	A	21022-2 NUT, HEX SL (8-32) DRAG STUD	122
2	-	A	2-21006-6 SCR, SKT SET (4-40x.62) DRAG	121
1	-	A	21009-2 SCR, SKT SET (1/4-20x.25)RAM	120
2	-	A	21017-2 SCR, DRIVE (#2x.19) ID PLATE	119
1	-	B	461264-1 PLATE, IDENTIFICATION	118
4	-	A	2-21002-2 SCR, BHC (8-32x.50) STRIPPER	117
1	-	A	2-21002-9 SCR, BHC (10-32x.75) CAP	116
1	-	A	22733-8 SCR, BHC (8-32x.38 LW) ANVIL	115
4	-	A	3-21002-3 SCR, BHC (1/4-20x.50) ST GD PL	114
3	-	A	2-22733-8 SCR, BHC (1/4-20x.62) H5G	113
2	-	A	2-21000-7 SCR, SHC (8-32x.50) SLUG BLADE	112
3	-	A	2-21000-5 SCR, SHC (8-32x.25) STRIP GUIDE	111
2	-	A	2-21000-8 SCR, SHC (8-32x.62) R STRIP GUIDE	110
2	-	A	3-21002-0 SCR, BHC (10-32x.88) SHEAR PL	109
1	-	A	457244-3 GUARD ASSY	108
1	-	A	690603-1 SPRING, ASSIST	107
1	-	A	23030-1 SCR, SKT CAP (6-32x.25) CP DSC	106
1	-	A	690191-1 PLUG, NYLON	105
1	-	C	455674-1 RAM	104
1	-	A	690125-1 WASHER, LAMINATED	103
1	-	A	690124-1 WASHER, RAM	102
1	-	A	7-21002-9 BOLT, CRIMPER (5/16-24x1.00)	101
1	-	A	23241-6 BALL, STEEL	99
1	-	A	690170-1 SPRING, COMPRESSION	98
1	-	C	690142-1 DISC, INSULATION	97
1	-	D	354777-1 WIRE DISC, PLASTIC	96
1	-	A	22480-5 WASHER, SPRING	95
1	-	B	690212-1 POST, RAM	94
1	-	B	3-690451-2 SPACER, STRIPPER	93
1	-	A	240639-1 STRIPPER	92
1	-	D	455676-1 PLATE, BASE	91
2	-	A	22354-8 DRAG, STUD	90
1	-	B	455678-2 PLATE, STRIP GUIDE	89
1	-	C	1-240825-2 PLATE, STRIP HOLD DOWN	88
2	-	A	4-22281-1 SPRING, DRAG	87
1	-	A	454177-1 DRAG, STOCK	86
2	-	C	461688-1 GUIDE, STRIP (FRONT)	85
1	-	C	690481-2 SPACER, HOLD DOWN	84
1	-	A	23846-1 SPRING, HOLD DOWN	83
1	-	B	240644-9 PLATE, REAR SHEAR	82
2	-	C	1-240645-6 SPACER, SHEAR PLATE	81
1	-	B	469723-2 PLATE, FRONT SHEAR	80
1	-	D	6-238005-0 ANVIL	79
1	-	B	240651-7 BLADE, SLUG	78
1	-	D	1-455892-9 HOLD DOWN, TERMINAL	77
1	-	C	2-240641-4 SPACER, SLUG BLADE	76
1	-	B	1-238009-7 SPACER, BLOCK CRIMPER	75
1	-	C	5-456134-2 CRIMPER, INSULATION	74
1	-	B	455888-1 SPACER, CRIMPER	73
1	-	C	456402-1 CRIMPER, WIRE	72
1	-	C	692655-5 AIR FEED VALVE ASSY	71

QTY REQD PER ASSY	U/M	DWG SIZE	PART NO	DESCRIPTION	ITEM NO
-1	U/M				

QTY REQD PER ASSY	U/M	DWG SIZE	PART NO	DESCRIPTION	ITEM NO
-1	U/M				
1	-	C	692655-5	AIR FEED VALVE ASSY	70
1	-	A	24042-2	VALVE, SHUT OFF	69
1	-	C	692655-6	AIR FEED VALVE ASSY	68
1	-	B	460277-1	AIR FEED ASSY (1 INCH)	67
2	-	A	3-21000-9	SCR, SHC (10-32x1.00) AIR ASSY	66
1	-	C	454220-1	CAP, RAM	65
1	-	D	453736-1	HOUSING	64
1	-	B	460680-5	FEED FINGER ASSY	63
1	-	A	690191-1	PLUG, NYLON	62
1	-	C	455674-1	RAM	61
1	-	A	690125-1	WASHER, LAMINATED	60
1	-	A	690124-1	WASHER, RAM	59
1	-	A	7-21002-9	BOLT, CRIMPER (5/16-24x1.00)	58
1	-	A	23241-6	BALL, STEEL	57
1	-	A	690170-1	SPRING, COMPRESSION	56
1	-	C	690142-1	DISC, INSULATION	55
1	-	D	354777-1	WIRE DISC, PLASTIC	54
1	-	A	22480-5	WASHER, SPRING	53
1	-	B	690212-1	POST, RAM	52
1	-	B	3-690451-2	SPACER, STRIPPER	51
1	-	A	240639-1	STRIPPER	50
1	-	D	455676-1	PLATE, BASE	49
2	-	A	22354-8	DRAG, STUD	48
1	-	B	455678-2	PLATE, STRIP GUIDE	47
1	-	C	1-240825-2	PLATE, STRIP HOLD DOWN	46
2	-	A	4-22281-1	SPRING, DRAG	45
1	-	A	454177-1	DRAG, STOCK	44
2	-	C	461688-1	GUIDE, STRIP (FRONT)	43
1	-	C	690481-2	SPACER, HOLD DOWN	42
1	-	A	23846-1	SPRING, HOLD DOWN	41
1	-	B	240644-9	PLATE, REAR SHEAR	40
2	-	C	1-240645-6	SPACER, SHEAR PLATE	39
1	-	B	469723-2	PLATE, FRONT SHEAR	38
1	-	D	6-238005-0	ANVIL	37
1	-	B	240651-7	BLADE, SLUG	36
1	-	D	1-455892-9	HOLD DOWN, TERMINAL	35
1	-	C	2-240641-4	SPACER, SLUG BLADE	34
1	-	B	1-238009-7	SPACER, BLOCK CRIMPER	33
1	-	C	5-456134-2	CRIMPER, INSULATION	32
1	-	B	455888-1	SPACER, CRIMPER	31
1	-	C	456402-1	CRIMPER, WIRE	30

QTY REQD PER ASSY	U/M	DWG SIZE	PART NO	DESCRIPTION	ITEM NO
-1	U/M				

LOC A
DIST 66

THIS DRAWING IS A CONTROLLED DOCUMENT FOR AMP INCORPORATED. IT IS SUBJECT TO CHANGE AND THE CONTROLLING ENGINEERING ORGANIZATION SHOULD BE CONTACTED FOR THE LATEST REVISION.

THIS INFORMATION IS CONFIDENTIAL AND IS DISCLOSED TO YOU ON CONDITION THAT NO FURTHER DISCLOSURE IS MADE BY YOU TO OTHER THAN AMP PERSONNEL WITHOUT WRITTEN AUTHORIZATION FROM AMP INCORPORATED, HARRISBURG, PA.

466361

D

C

B

A