

ATLANTIC VERSION TERMINATOR INTERFACE ADAPTER	PART NUMBER	REVISION	DESCRIPTION	FEED TYPE	APPLICATOR STYLE CONVERSION CHART						
					CONVERT TO	PART NUMBERS REQUIRED					
	2837397-2	A	FINE CRIMP HEIGHT ADJUST	PNEUMATIC	-	-	-	-	-	-	
					SERVO LATCH PLATE SMART APPLICATOR	2119951-1	-	8-2837397-5	1901094-3	2168400-6 (QUANTITY 2)	
	2837397-5	A	FINE CRIMP HEIGHT ADJUST	SERVO LATCH PLATE ⁴	-	-	-	-	-	-	
					PNEUMATIC FEED	2119950-1	1338683-8	5-18022-5	2119641-1	2119799-1	2063440-2
	2837397-6	A	NON-CRIMP HEIGHT ADJUST	SERVO LATCH PLATE ⁴	-	-	-	-	-	-	
	2837397-7	A	FINE CRIMP HEIGHT ADJUST	NONE	-	-	-	-	-	-	
	7-2837397-7	A	CRIMP TOOLING KIT	-	-	-	-	-	-	-	

APPLICATOR DATA		
CRIMP	SIZE	TYPE
WIRE	2.79 mm [.110]	F
INSUL	3.30 mm [.130]	F

APPLICATOR INSTRUCTIONS 408-10389

TERMINAL DATA: ZHENG YAO TERMINAL TE CRIMP SPECIFICATION			
TERMINAL NAME: TERMINAL			
WIRE STRIP LENGTH	TERMINAL INSULATION DIAMETER RANGE		
5.79-6.55 mm [.228-.258 IN]	Ø1.91-2.54 mm [.075-.100 IN]		
TERMINAL APPLICATION SPECIFICATION	NONE		
TERMINALS APPLIED			
TE TERMINAL	ZHENG YAO TERMINAL	TE TERMINAL	ZHENG YAO TERMINAL
3311301-1	DJ626-6.3B/PS2		

WIRE SIZE	CRIMP HEIGHT mm [INCH]	CRIMP HEIGHT REFERENCE SETTING
1.25±0.30	1.81±/-0.05 [.071±/-0.002]	5.6
0.85±0.50	1.75±/-0.05 [.069±/-0.002]	6.3
1.25mm2	1.72±/-0.05 [.068±/-0.002]	6.7

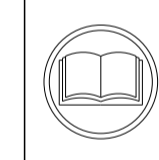

- RECOMMENDED SPARE PARTS
- GREASE BEARING SURFACES LIGHTLY
- LUBRICATE DAILY PER THE APPLICATOR INSTRUCTION SHEET SUPPLIED WITH THE APPLICATOR.
- APPLICATOR SPECIFIC DATA TO BE ENTERED INTO BLANK MEMORY CHIP AT ASSEMBLY. SEE BELOW FOR PART NUMBER:
 PNEUMATIC FEED WITH "SMART APPLICATOR" CONVERSION: 8-2837397-4
 SERVO FEED WITH "FINE CRIMP HEIGHT ADJUST": 8-2837397-5
 SERVO FEED WITH "NON-CRIMP HEIGHT ADJUST": 8-2837397-6
- ADJUSTMENT OF THE STRIPPER MAY BE REQUIRED WHEN MOVING THE APPLICATOR BETWEEN BENCH AND LEADMAKER APPLICATIONS.
- APPLY PART NUMBER 1-23419-5 LOCTITE TO THREADS OF ITEMS 62. APPLY PART NUMBER 2-23419-6 LOCTITE TO THREADS OF ITEM 242. FOR -6 ONLY APPLY PART NUMBER 1-23419-5 LOCTITE TO THREADS OF ITEMS 37.
- GREASE THREADS, GROOVE AND O-RING ON ITEMS 35 & 252.
- MAGNET, ITEM 166 MUST BE ORIENTED CORRECTLY IN ORDER TO PROPERLY ACTUATE THE COUNTER.
- CRIMP HEIGHT REFERENCE SETTING WAS THE SETTING USED WHEN THE APPLICATOR WAS QUALIFIED AT THE FACTORY. ADJUSTMENT MAY BE NECESSARY WHEN RUNNING APPLICATOR IN THE FIELD.
- TERMINAL PITCH NOT COMPATIBLE WITH MECHANICAL FEED.
- TO CONVERT THE APPLICATOR TO A NON-CARRIER CUTTING STYLE, REMOVE ITEM 13 AND ATTACH TO THE LOCATION ON THE BACK SIDE OF THE HOUSING. REFER TO INSTRUCTION SHEET FOR ADDITIONAL INFORMATION.
- WHEN ASSEMBLING A NON CRIMP HEIGHT ADJUST APPLICATOR (-6) USE SHIMS FROM ITEM 260 TO ACHIEVE A NOMINAL SHIM HEIGHT OF 3.99.

13. UNLESS SPECIFIED OTHERWISE TORQUE VALUES SHALL BE USED PER DOCUMENT 101-35000.

***WARNING**
 ON INSTALLATION, SET WIRE DISC, ITEM 40 TO LARGEST WIRE SIZE SETTING. USE OF SETTINGS BELOW MINIMUM REQUIRED CRIMP HEIGHT SETTING WILL CAUSE DAMAGE TO CRIMP TOOLING.

ATLANTIC VERSION
 Shown on sheets 1 of 4 & 2 of 4
 (Pacific version shown on sheets 3 of 4 & 4 of 4)

SET UP GAUGE		LOC	DIST	REVISIONS			
2119599-1		A	66	REV	DATE	BY	CHK
				1	DEVELOPMENT	14AUG2018	MZ
				A	RELEASED	13SEP2018	TB

-	-	1	-	-	2119957-2	APPLICATOR SHIM PACK	260
-	1	1	1	1	1803078-3	SPACER, PRECISION	259
-	1	-	1	1	8-21084-0	O-RING, .676 ID, .070 DIA. MAT.	252
-	-	-	-	1	2119640-1	PUSH ROD, AIR FEED	250
-	-	-	-	1	1803259-1	BUSHING, FLANGED	249
-	-	-	-	1	2119641-1	FEED CAM, AIR FEED	248
-	1	-	1	1	2119798-1	DETENT PIN	247
-	1	-	1	1	1-22279-3	SPRING, COMPRESSION	246
-	-	1	-	-	2161314-1	RAM, STEPPED, ATLANTIC, SF, NON-ADJ	245
-	1	1	1	1	2119082-3	CAM, SNAIL, INSULATION ADJUSTMENT	244
-	1	1	1	1	2079764-1	WASHER, WAVE SPRING, CREST-TO-CREST	243
-	1	1	1	1	2119083-1	RETAINER, INSULATION DIAL	242
-	1	1	1	1	7-18023-7	SCR, SKT HD CAP M3 X 4.0	241
-	-	2	2	-	2168400-6	SHCS, LOW HEAD, RoHS, M5 X 16	240
-	-	-	-	1	2063440-2	AIR FEED MODULE	238
-	-	1	1	-	2119740-2	TAG IDENTIFICATION	213
-	-	1	1	-	1901094-3	SPACER, FEEDER	198
-	-	-	-	2	21045-3	RING, RETAIN, EXTERN, 3/16 CRESCENT	172
-	1	1	1	1	994969-1	MAGNET, RARE EARTH HIGH ENERGY	166
-	REF	REF	REF	REF	994970-2	COUNTER, MAGNETIC	164
-	-	-	-	1	240638-1	SPRING, FEED FINGER	163
-	-	-	-	1	3-23627-7	PIN, RETAIN, GRVD, 3/16 X .854	137
-	-	-	-	1	2119799-1	HOLDER, FEED FINGER, AF	136
-	-	REF	REF	-	SEE NOTE 4	MEMORY CHIP, PROGRAMMED	135
-	-	1	1	-	1633743-1	SERVO FEED LATCH ASM	133
-	-	REF	REF	-	2119944-1	FEED FINGER ASSEMBLY, SF	117
-	1	1	1	1	455888-9	SPACER, CRIMPER	82
-	1	1	1	1	2119956-1	DOCUMENTATION PACKAGE	71
-	1	1	1	1	2119791-5	DEPRESSOR, WIRE	70
-	1	-	-	1	2119740-1	TAG IDENTIFICATION	67
-	2	2	2	2	2168078-1	SCREW, DRIVE, RH, RoHS, 2 x .188	66
-	1	-	1	1	2119793-1	LIMITER, ADJUSTMENT BOLT	63
-	3	-	3	3	992763-5	SCR, SET, SOC, CONE PNT, M3 X 4.0	62
-	1	1	1	1	2079383-4	SCR, BHSC, RoHS (M4 X 8)	60
-	-	-	-	1	5-18022-5	SCR, HEX HD CAP, M4 X 6.0	59
-	-	-	-	1	1338683-8	FEED PAWL	56
-	4	4	4	4	2168400-1	SHCS, LOW HEAD, RoHS, M4 X 12	54
-	2	2	2	2	1-2168083-0	SCR, SKT HD CAP, RoHS, M4 X 10	53
-	1	1	1	1	1803382-2	HOLD DOWN, SPRING LOADED	50
-	-	-	-	1	18023-9	SCR, SKT HD CAP M4 X 6.0	49
-	1	1	1	1	2119656-9	APPLICATOR BASIC ASSEMBLY, SF	46
-	1	-	1	1	2161311-1	RAM, STEPPED, AMP STYLE, SIDE FEED	44
-	1	1	1	1	1-2079383-5	SCR, BHSC, RoHS (M8 X 40)	41
-	1	-	1	1	2119645-1	DISC, NUMBERED FA WIRE ADJUSTMENT	40
-	1	-	1	1	2119957-1	APPLICATOR SHIM PACK	39
-	1	1	1	1	1-2119644-2	RAM WASHER, PRECISION	38
-	1	1	1	1	2119085-1	FA HEAD, ATLANTIC STYLE	37
-	1	-	1	1	2119092-1	BOLT, ADJUSTMENT	35
-	1	1	1	1	3-1752356-3	SUPPORT, TERMINAL	34
-	2	2	2	2	2079383-5	SCR, BHSC, RoHS (M4 X 20)	33
-	1	1	1	1	2161328-1	HEX HEAD, FLANGED, M5 X 8mm LONG	32
-	1	1	1	1	1-1320908-2	SPACER, STRIP GUIDE	30
-	1	1	1	1	2119959-1	ASSEMBLY, STRIP GUIDE	29
-	1	1	1	1	1320928-2	STRIP GUIDE	24
-	1	1	1	1	2168083-2	SCR, SKT HD CAP, RoHS, M4 X 8.0	21
-	2	2	2	2	1-18028-2	WASHER, FLAT, REG M4	20
-	1	1	1	1	2119533-1	STRIPPER, SIDE FEED	19
-	1	1	1	1	2119806-1	INSERT, SHEAR	13
-	1	1	1	1	3-22280-3	SPRING, COMPRESSION	12
-	1	1	1	1	1-356885-4	STOP, SHEAR	11
-	1	1	1	1	2119805-1	SHEAR HOLDER, FRONT	10
-	1	1	1	1	1803095-3	FLOATING SHEAR, FRONT	9
-	1	1	1	1	4-1633923-8	ANVIL, COMBINATION	8
-	-	-	-	-	-	-	7
-	-	-	-	-	-	-	6
-	1	1	1	1	2119757-8	DEPRESSOR, SHEAR	5
-	1	1	1	1	2-238011-1	BLOCK, CRIMPER SPACER	4
-	1	1	1	1	1-1803017-6	CRIMPER, INSULATION F	3
-	1	1	1	1	1-455888-1	SPACER, CRIMPER	2
-	1	1	1	1	4-1633730-7	CRIMPER, WIRE	1

DIMENSIONS:		TOLERANCES UNLESS OTHERWISE SPECIFIED:		DRAWING NO		RESTRICTED TO	
mm	0 PLC	±		0779	2837397		
	1 PLC	±					
	2 PLC	±					
	3 PLC	±					
	4 PLC	±					
	ANGLES	±					
MATERIAL	FINISH			WT			

LOC	DIST	REV	DATE	BY	APPV
A	66				

REVISIONS			
REV	DATE	BY	APPV
-	SEE SHEET 1	-	-

FEED TYPE

PNEUMATIC

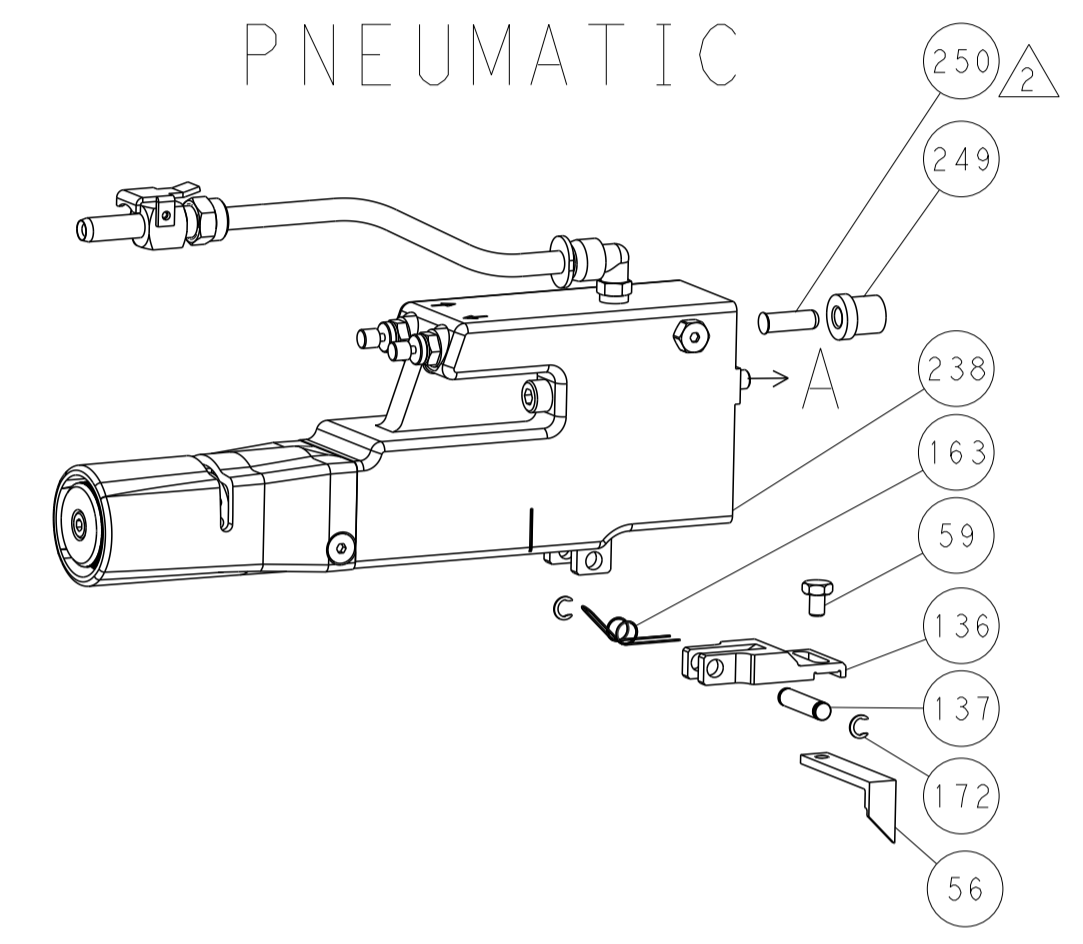

SERVO LATCH PLATE

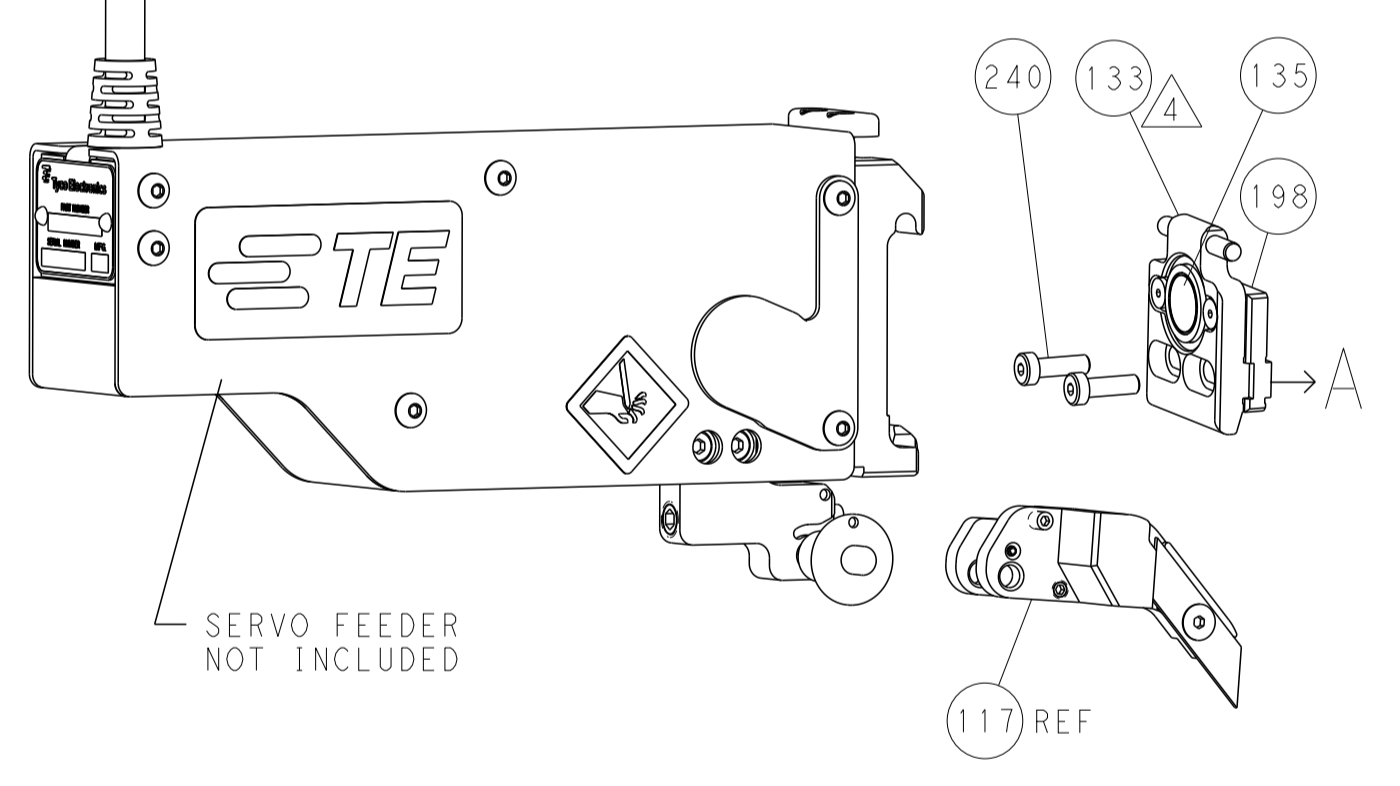

CAM POSITION

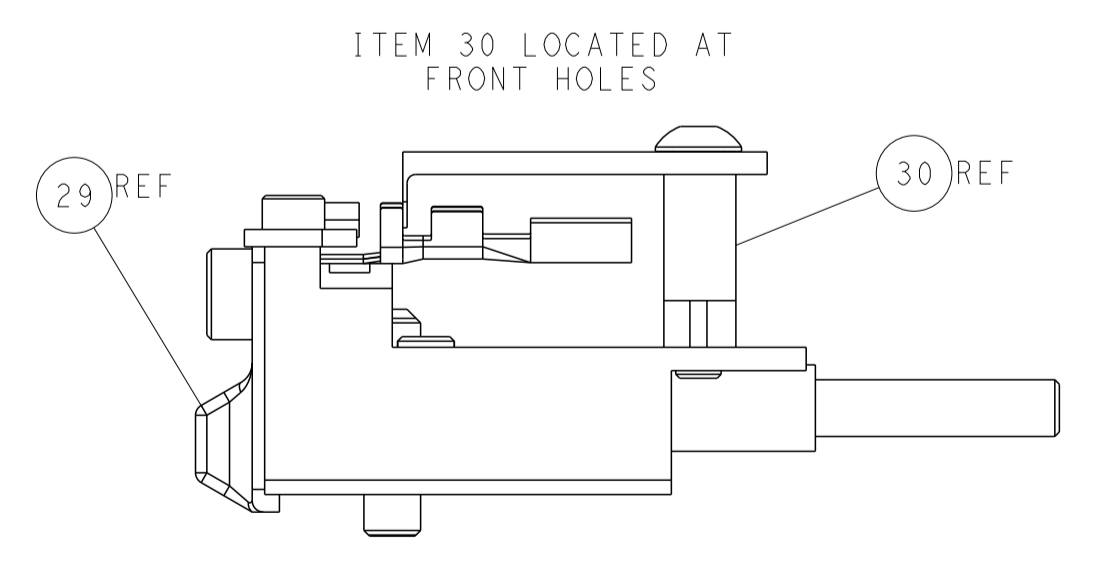
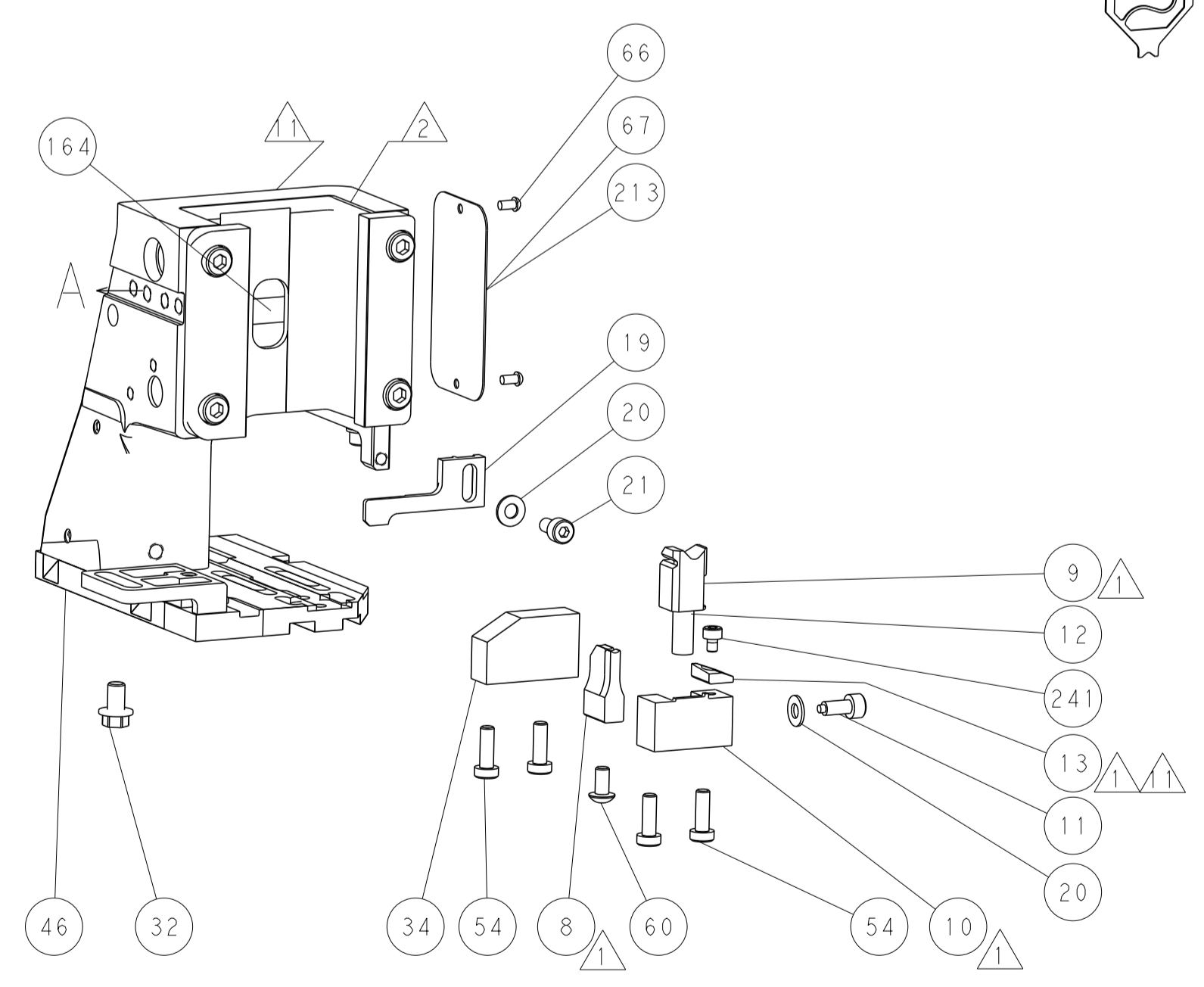
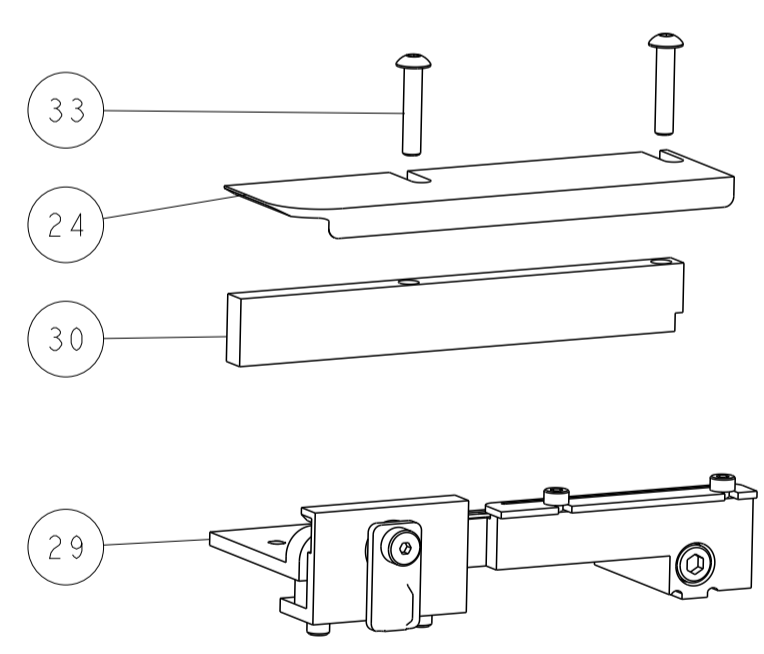
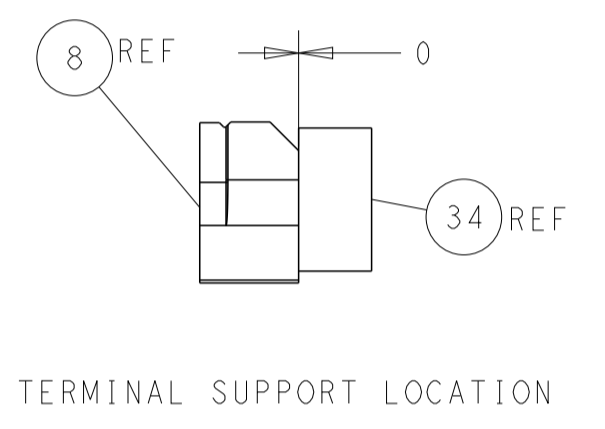
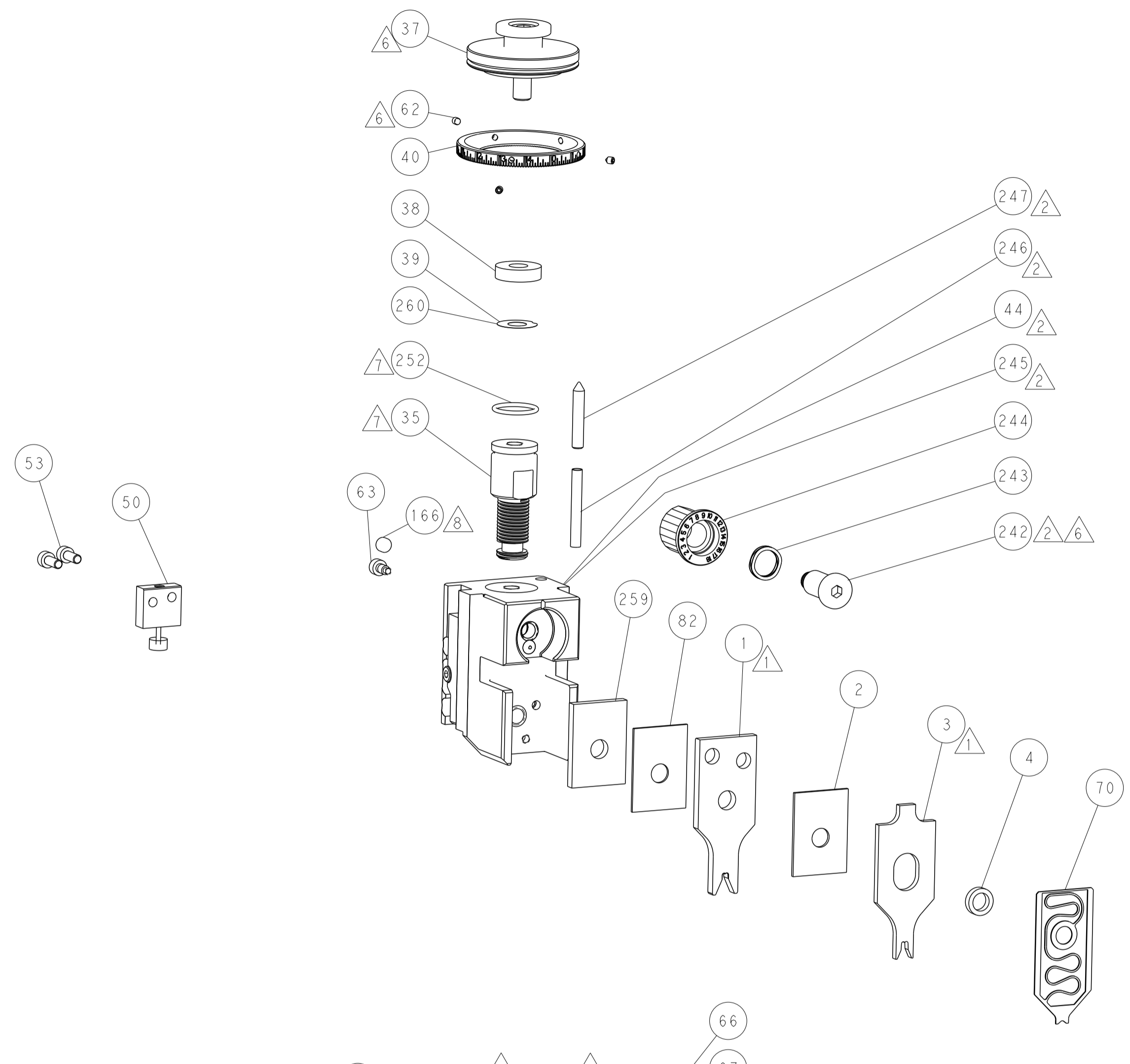
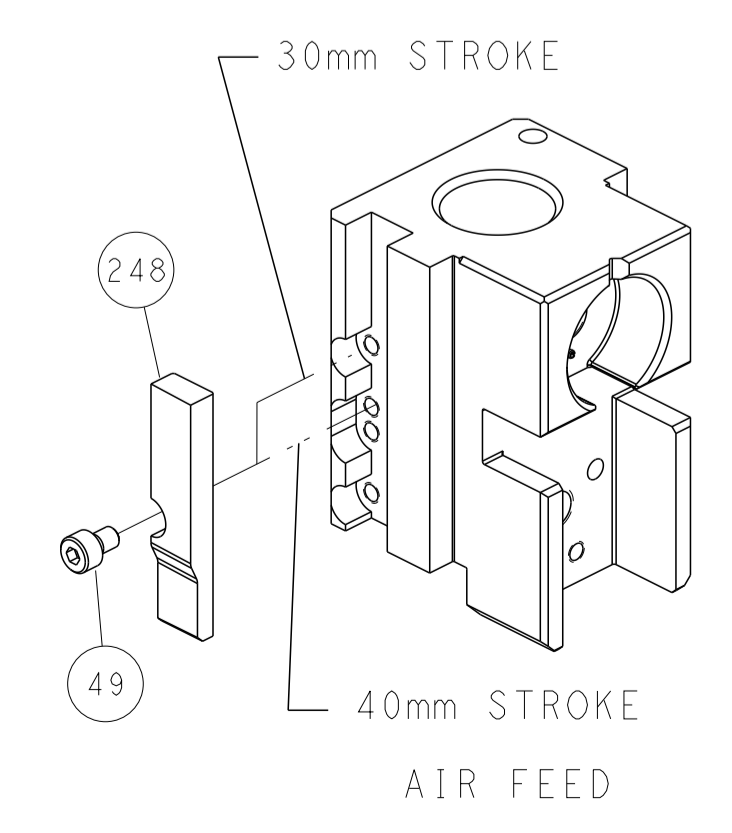

FEED TRACK POSITION GUIDE BY INSULATION BARREL

ATLANTIC VERSION
 Shown on sheets 1 of 4 & 2 of 4
 (Pacific version shown on sheets 3 of 4 & 4 of 4)

DIMENSIONS:		TOLERANCES UNLESS OTHERWISE SPECIFIED:		DWG: M. ZHAO 14AUG2018		TE Connectivity	
mm	0 PLC ±	1 PLC ±	2 PLC ±	3 PLC ±	4 PLC ±	Harrisburg, PA 17105-3608	
MATERIAL:		FINISH:		CHK: K. ZHANG 14AUG2018		NAME: Ocean Side Feed Applicator	
				APVD: K. ZHANG 14AUG2018		SIZE: A1	
				PRODUCT SPEC:		CAGE CODE: 00779	
				APPLICATION SPEC:		DRAWING NO: 2837397	
				WEIGHT:		SCALE: 1:2	
				Customer Accessible Production Drawing		SHEET 2 OF 4	
						REV A	

PACIFIC VERSION TERMINATOR INTERFACE ADAPTER	PART NUMBER	REVISION	DESCRIPTION	FEED TYPE	CONVERT TO	PART NUMBERS REQUIRED					
	2-2837397-2	A	FINE CRIMP HEIGHT ADJUST	PNEUMATIC	SERVO LATCH PLATE	2119951-1	-	8-2837397-5	1901094-3	-	2168400-6 (QUANTITY 2)
	2-2837397-5	A	FINE CRIMP HEIGHT ADJUST	SERVO LATCH PLATE ⁴	SMART APPLICATOR	2161326-1	-	8-2837397-4	-	-	-
	2-2837397-7	A	FINE CRIMP HEIGHT ADJUST	NONE	PNEUMATIC FEED	2119950-1	1338683-8	5-18022-5	2119641-2	2119799-1	2063440-2
	7-2837397-7	A	CRIMP TOOLING KIT	-	-	-	-	-	-	-	-

APPLICATOR DATA		
CRIMP	SIZE	TYPE
WIRE	2.79 mm [.110]	F
INSUL	3.30 mm [.130]	F
APPLICATOR INSTRUCTIONS 408-10389		

TERMINAL DATA: ZHENG YAO TERMINAL TE CRIMP SPECIFICATION			
TERMINAL NAME: TERMINAL			
WIRE STRIP LENGTH		TERMINAL INSULATION DIAMETER RANGE	
5.79-6.55 mm [.228-.258 IN]		Ø1.91-2.54 mm [.075-.100 IN]	
TERMINAL APPLICATION SPECIFICATION	NONE		
TERMINALS APPLIED ¹⁰			
TE TERMINAL	ZHENG YAO TERMINAL	TE TERMINAL	ZHENG YAO TERMINAL
3311301-1	DJ626-6.3B/PS2		

WIRE SIZE	CRIMP HEIGHT mm [INCH]	CRIMP HEIGHT REFERENCE SETTING ⁹
1.25±0.30	1.81±0.05 [.071±.002]	5.6
0.85±0.50	1.75±0.05 [.069±.002]	6.3
1.25mm ²	1.72±0.05 [.068±.002]	6.7

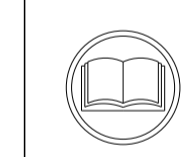

- ¹ RECOMMENDED SPARE PARTS
- ² GREASE BEARING SURFACES LIGHTLY
3. LUBRICATE DAILY PER THE APPLICATOR INSTRUCTION SHEET SUPPLIED WITH THE APPLICATOR.
- ⁴ APPLICATOR SPECIFIC DATA TO BE ENTERED INTO BLANK MEMORY CHIP AT ASSEMBLY. SEE BELOW FOR PART NUMBER:
PNEUMATIC FEED WITH "SMART APPLICATOR" CONVERSION: 8-2837397-4
SERVO FEED WITH "FINE CRIMP HEIGHT ADJUST": 8-2837397-5
5. ADJUSTMENT OF THE STRIPPER MAY BE REQUIRED WHEN MOVING THE APPLICATOR BETWEEN BENCH AND LEADMAKER APPLICATIONS.
- ⁶ APPLY PART NUMBER 1-23419-5 LOCTITE TO THREADS OF ITEMS 62.
APPLY PART NUMBER 2-23419-6 LOCTITE TO THREADS OF ITEM 242.
- ⁷ GREASE THREADS, GROOVE AND O-RING ON ITEMS 139 & 152.
- ⁸ MAGNET MUST BE ORIENTED CORRECTLY IN ORDER TO PROPERLY ACTUATE THE COUNTER.
- ⁹ CRIMP HEIGHT REFERENCE SETTING WAS THE SETTING USED WHEN THE APPLICATOR WAS QUALIFIED AT THE FACTORY. ADJUSTMENT MAY BE NECESSARY WHEN RUNNING APPLICATOR IN THE FIELD.
- ¹⁰ TERMINAL PITCH NOT COMPATIBLE WITH MECHANICAL FEED.
- ¹¹ TO CONVERT THE APPLICATOR TO A NON-CARRIER CUTTING STYLE, REMOVE ITEM 13 AND ATTACH TO THE LOCATION ON BACK SIDE OF THE HOUSING. REFER TO INSTRUCTION SHEET FOR ADDITIONAL INFORMATION.
12. UNLESS SPECIFIED OTHERWISE TORQUE VALUES SHALL BE USED PER DOCUMENT 101-35000.

***WARNING**
ON INSTALLATION, SET WIRE DISC, ITEM 40 TO LARGEST WIRE SIZE SETTING. USE OF SETTINGS BELOW MINIMUM REQUIRED CRIMP HEIGHT SETTING WILL CAUSE DAMAGE TO CRIMP TOOLING.

PACIFIC VERSION
Shown on sheets 3 of 4 & 4 of 4
(Atlantic version shown on sheets 1 of 4 & 2 of 4)

SET UP GAUGE	LOC	DIST	REVISIONS			
2119599-1	A	66	REV	DATE	BY	APPD
			-	SEE SHEET 1	-	-

-	1	1	1	1803078-3	SPACER, PRECISION	259
-	1	1	1	2119782-1	FINE ADJUST HEAD ASM, PACIFIC STYLE	251
-	-	-	1	2119640-1	PUSH ROD, AIR FEED	250
-	-	-	1	1803259-1	BUSHING, FLANGED	249
-	1	1	1	1-22279-3	SPRING, COMPRESSION	246
-	1	1	1	2119082-3	CAM, SNAIL, INSULATION ADJUSTMENT	244
-	1	1	1	2079764-1	WASHER, WAVE SPRING, CREST-TO-CREST	243
-	1	1	1	2119083-1	RETAINER, INSULATION DIAL	242
-	1	1	1	7-18023-7	SCR, SKT HD CAP M3 X 4.0	241
-	-	2	-	2168400-6	SHCS, LOW HEAD, RoHS, M5 X 16	240
-	-	-	1	2063440-2	AIR FEED MODULE	238
-	-	1	-	2119740-2	TAG IDENTIFICATION	213
-	-	1	-	1901094-3	SPACER, FEEDER	198
-	-	-	2	21045-3	RING, RETAIN, EXTERN, 3/16 CRESCENT	172
-	1	1	1	994969-1	MAGNET, RARE EARTH HIGH ENERGY	166
-	REF	REF	REF	994970-2	COUNTER, MAGNETIC	164
-	-	-	1	240638-1	SPRING, FEED FINGER	163
-	1	1	1	8-21084-1	O-RING, .801 ID, .070 DIA. MAT.	152
-	-	-	1	2119641-2	FEED CAM, AIR FEED	151
-	1	1	1	2119798-2	DETENT PIN	145
-	1	1	1	2079383-8	SCR, BHSC, RoHS (M4 X 16)	144
-	4	4	4	2168400-5	SHCS, LOW HEAD, RoHS, M4 X 20	143
-	1	1	1	1-2119656-0	APPLICATOR BASIC ASSEMBLY, SF	141
-	1	1	1	2161312-1	RAM, STEPPED, ASIAN STYLE, SIDE FEED	140
-	1	1	1	2119092-2	BOLT, ADJUSTMENT	139
-	-	-	1	3-23627-7	PIN, RETAIN, GRVD, 3/16 X .854	137
-	-	-	1	2119799-1	HOLDER, FEED FINGER, AF	136
-	-	REF	-	SEE NOTE 4	MEMORY CHIP, PROGRAMMED	135
-	-	1	-	1633743-1	SERVO FEED LATCH ASM	133
-	-	REF	-	2119944-1	FEED FINGER ASSEMBLY, SF	117
-	1	1	1	455888-9	SPACER, CRIMPER	82
-	1	1	1	2119956-1	DOCUMENTATION PACKAGE	71
-	1	1	1	2119791-5	DEPRESSOR, WIRE	70
-	1	-	1	2119740-1	TAG IDENTIFICATION	67
-	2	2	2	2168078-1	SCREW, DRIVE, RH, RoHS, 2 x .188	66
-	1	1	1	2119793-1	LIMITER, ADJUSTMENT BOLT	63
-	3	3	3	992763-5	SCR, SET, SOC, CONE PNT, M3 X 4.0	62
-	-	-	1	5-18022-5	SCR, HEX HD CAP, M4 X 6.0	59
-	-	-	1	1338683-8	FEED PAWL	56
-	2	2	2	1-2168083-0	SCR, SKT HD CAP, RoHS, M4 X 10	53
-	1	1	1	1803382-2	HOLD DOWN, SPRING LOADED	50
-	-	-	1	18023-9	SCR, SKT HD CAP M4 X 6.0	49
-	1	1	1	1-2079383-5	SCR, BHSC, RoHS (M8 X 40)	41
-	1	1	1	2119645-1	DISC, NUMBERED FA WIRE ADJUSTMENT	40
-	1	1	1	2119957-1	APPLICATOR SHIM PACK	39
-	1	1	1	1-2119644-2	RAM WASHER, PRECISION	38
-	1	1	1	3-1752356-3	SUPPORT, TERMINAL	34
-	2	2	2	2079383-5	SCR, BHSC, RoHS (M4 X 20)	33
-	1	1	1	2161328-1	HEX HEAD, FLANGED, M5 X 8mm LONG	32
-	1	1	1	1-1320908-2	SPACER, STRIP GUIDE	30
-	1	1	1	2119959-1	ASSEMBLY, STRIP GUIDE	29
-	1	1	1	1320928-2	STRIP GUIDE	24
-	1	1	1	2168083-2	SCR, SKT HD CAP, RoHS, M4 X 8.0	21
-	2	2	2	1-18028-2	WASHER, FLAT, REG M4	20
-	1	1	1	2119533-1	STRIPPER, SIDE FEED	19
-	1	1	1	2119806-1	INSERT, SHEAR	13
-	1	1	1	3-22280-3	SPRING, COMPRESSION	12
-	1	1	1	1-356885-4	STOP, SHEAR	11
-	1	1	1	2119805-1	SHEAR HOLDER, FRONT	10
-	1	1	1	1803095-3	FLOATING SHEAR, FRONT	9
-	1	1	1	4-1633923-8	ANVIL, COMBINATION	8
-	-	-	-	-	-	7
-	-	-	-	-	-	6
-	1	1	1	2119757-8	DEPRESSOR, SHEAR	5
-	1	1	1	2-238011-1	BLOCK, CRIMPER SPACER	4
-	1	1	1	1-1803017-6	CRIMPER, INSULATION F	3
-	1	1	1	1-455888-1	SPACER, CRIMPER	2
-	1	1	1	4-1633730-7	CRIMPER, WIRE	1

DIMENSIONS:		TOLERANCES UNLESS OTHERWISE SPECIFIED:		DRAWING NO		RESTRICTED TO	
mm	0 PLC ±.1	1 PLC ±.15	2 PLC ±.2	3 PLC ±.25	4 PLC ±.3	ANGLES ±.1	FINISH
MATERIAL				WEIGHT	SCALE	SHEET	REV
-				-	A1 00779	3	A

STE TE Connectivity
Harrisburg, PA 17105-3608

NAME: Ocean Side Feed Applicator

Customer Accessible Production Drawing

LOC		DIST		REVISIONS			
A	66	P	LTM	DESCRIPTION	DATE	OWN	APVD
		-		SEE SHEET 1			

FEED TYPE PNEUMATIC

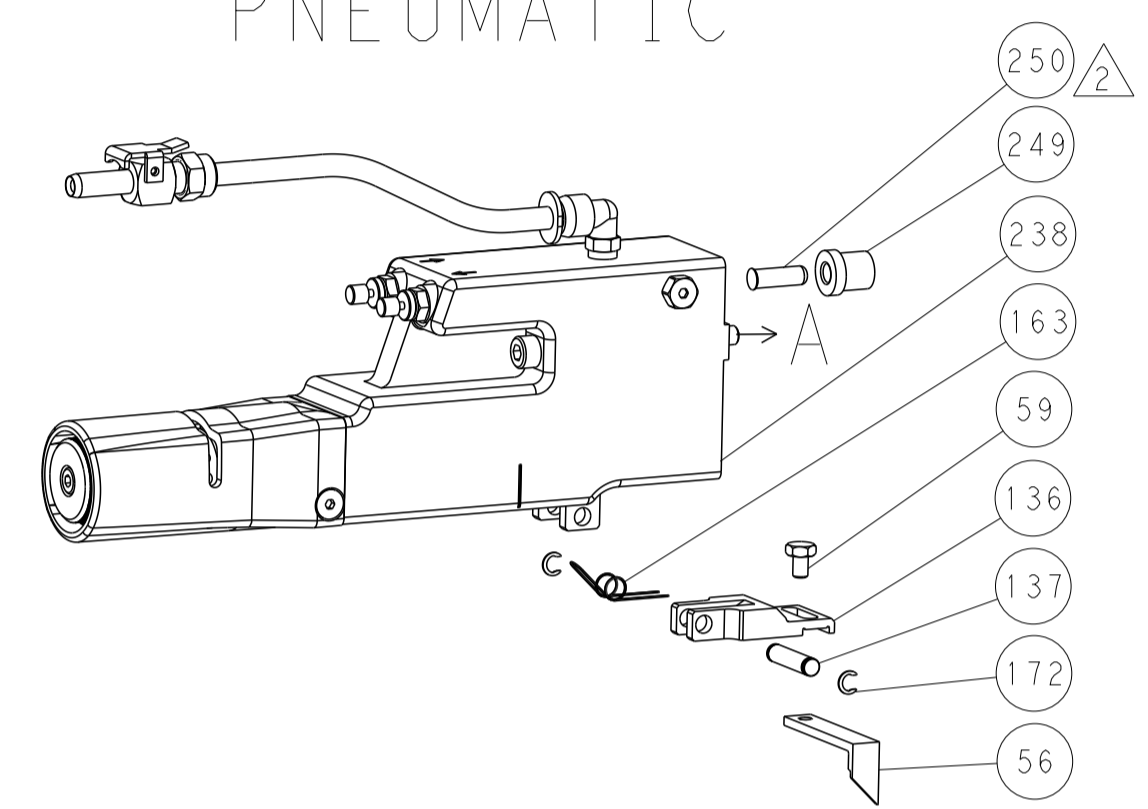

SERVO LATCH PLATE

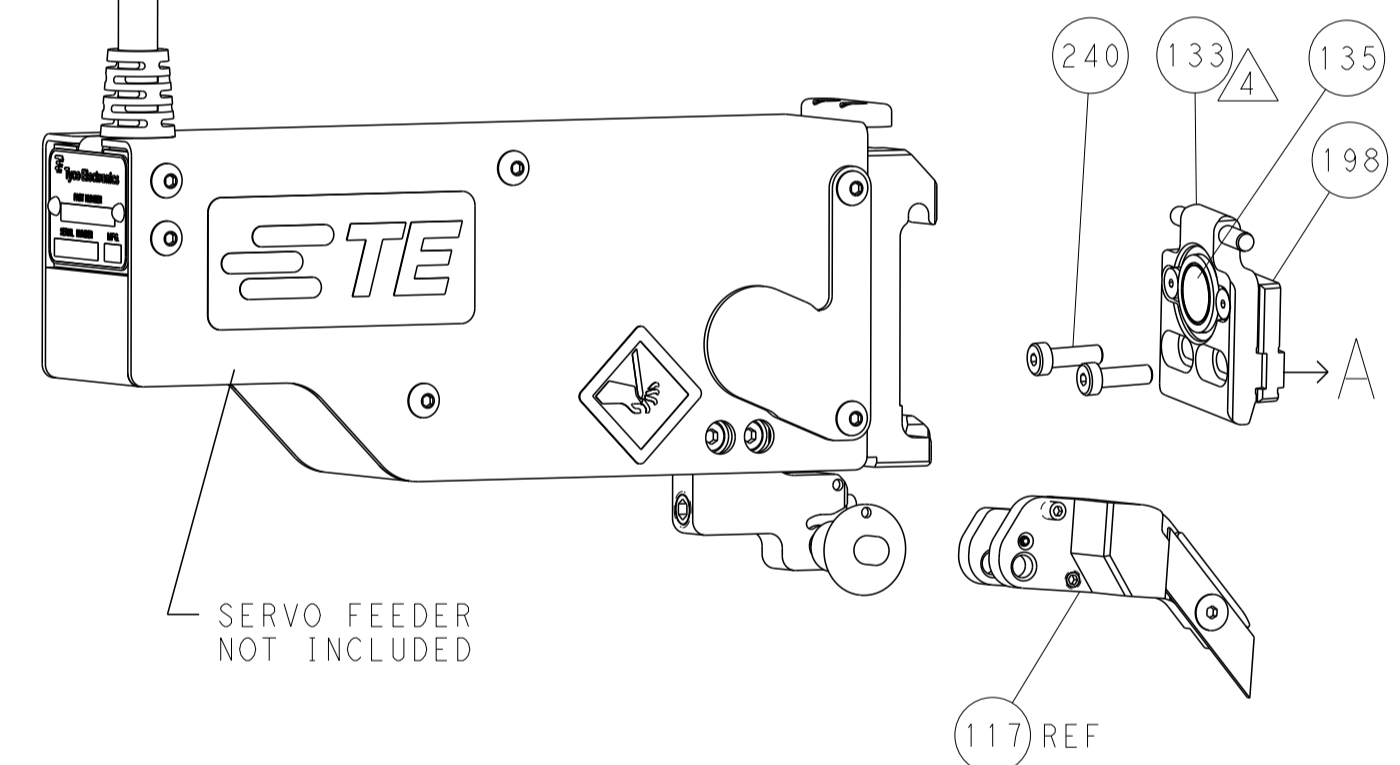

CAM POSITION

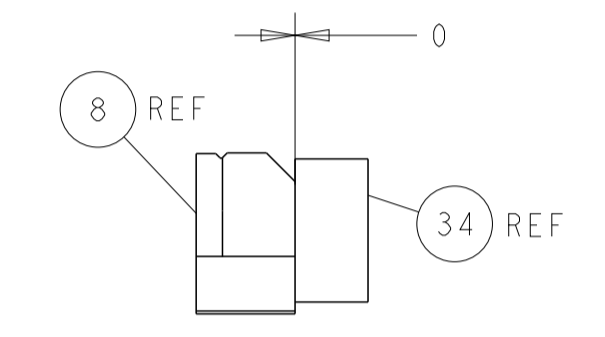
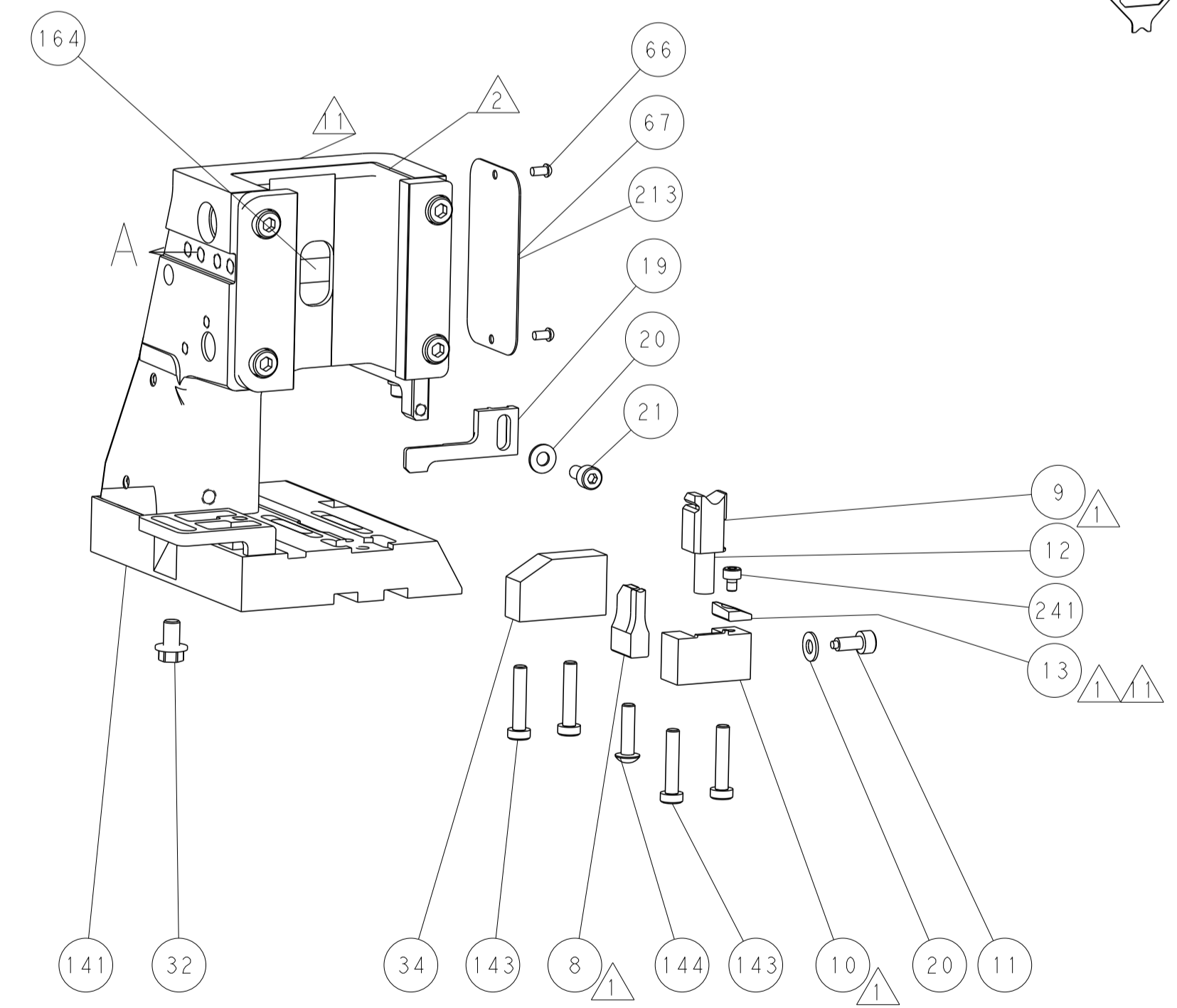
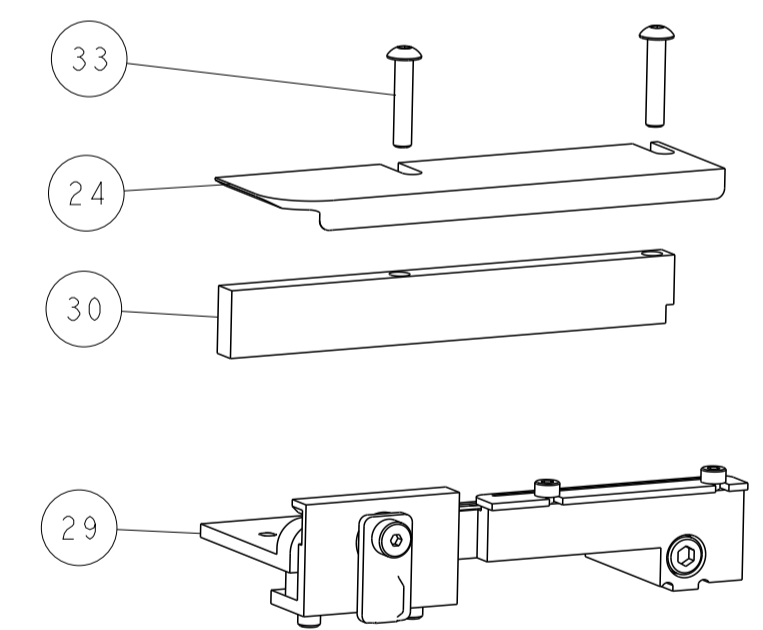
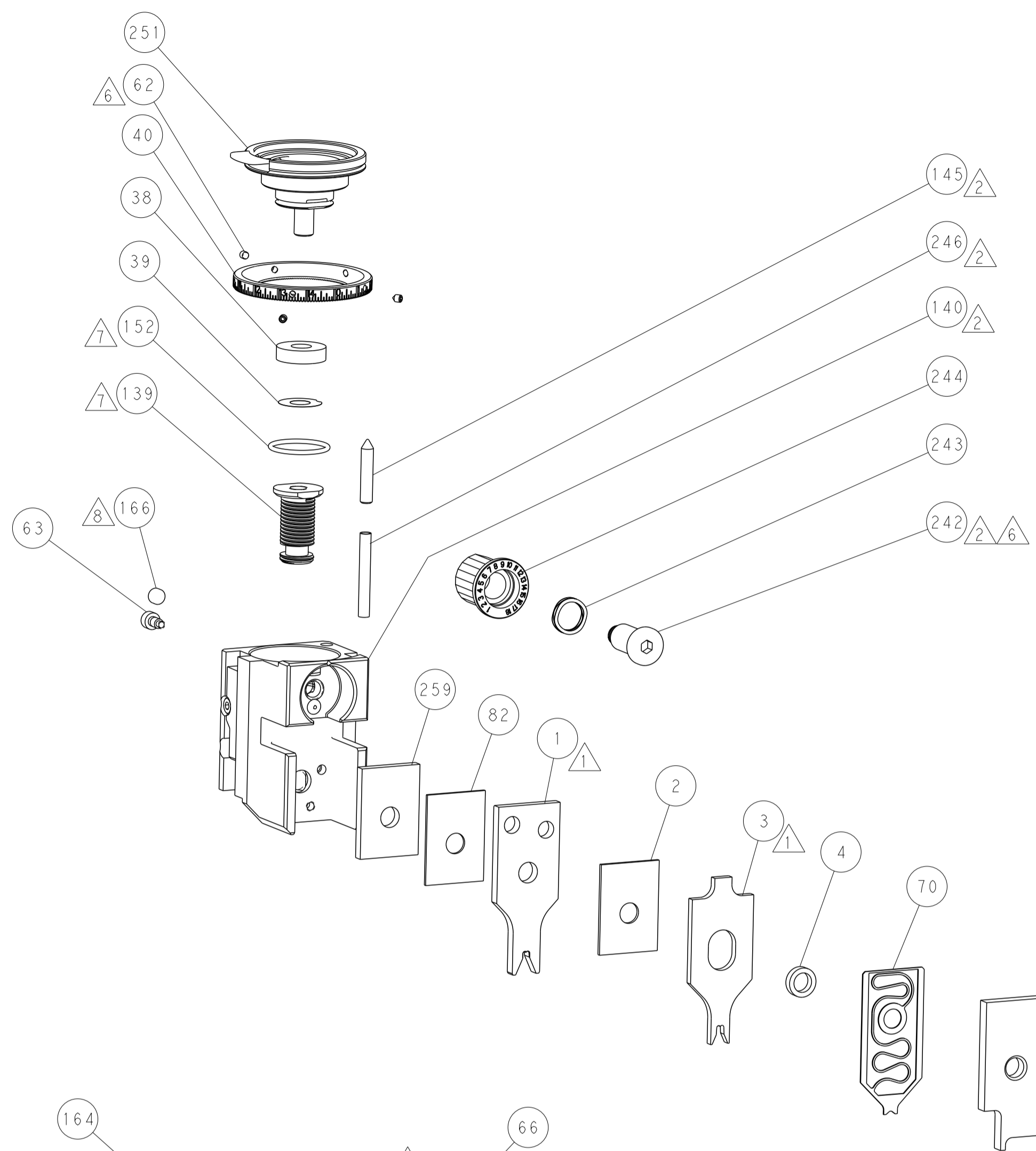
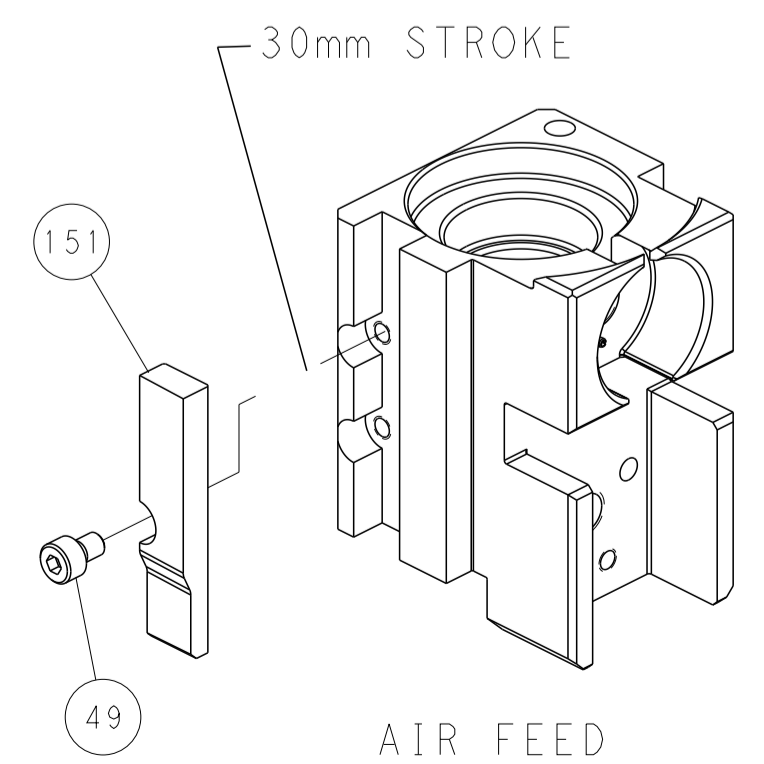

TERMINAL SUPPORT LOCATION

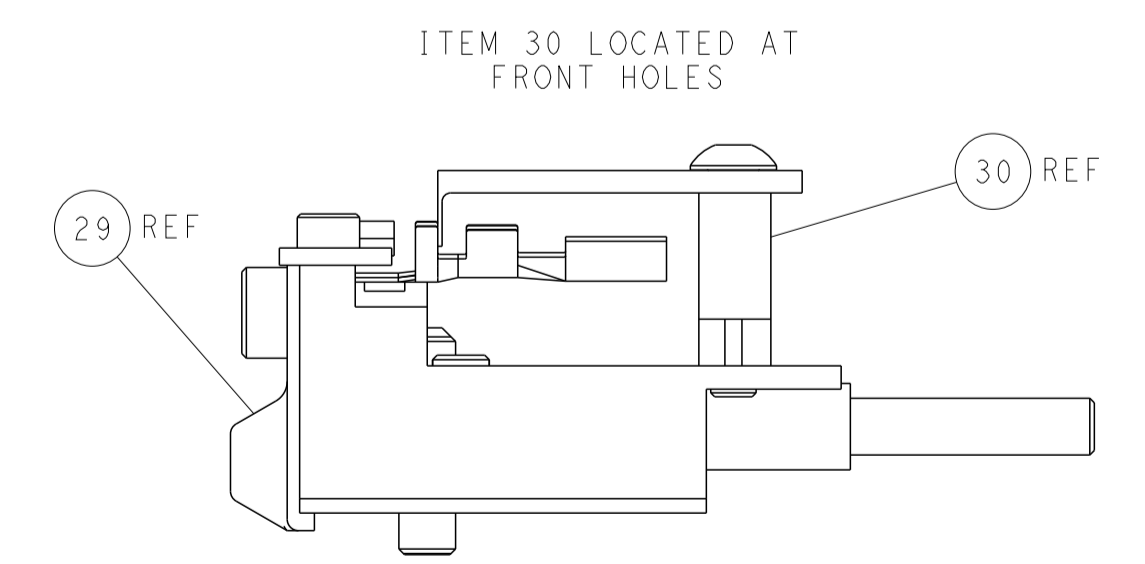

FEED TRACK POSITION
GUIDE BY INSULATION BARREL

PACIFIC VERSION
 Shown on sheets 3 of 4 & 4 of 4
 (Atlantic version shown on sheets 1 of 4 & 2 of 4)

<small>THIS DRAWING IS UNPUBLISHED. RELEASED FOR PUBLICATION. IT IS THE PROPERTY OF TYCO ELECTRONICS CORPORATION. IT IS TO BE USED ONLY FOR THE PURPOSES AND IN THE QUANTITIES SPECIFIED IN THE ORDER. IT IS TO BE RETURNED TO TYCO ELECTRONICS CORPORATION UPON COMPLETION OF THE PROJECT.</small>		DWN: M. ZHAO 14AUG2018 CHK: K. ZHANG 14AUG2018 APVD: K. ZHANG 14AUG2018	NAME: TE Connectivity Harrisburg, PA 17105-3608
DIMENSIONS: mm TOLERANCES UNLESS OTHERWISE SPECIFIED: 0 PLC ± 1 PLC ± 2 PLC ± 3 PLC ± 4 PLC ± ANGLES ± MATERIAL: - FINISH: -		PRODUCT SPEC: APPLICATION SPEC: WEIGHT: - SCALE: 1:2	Ocean Side Feed Applicator SIZE: A1 CAGE CODE: 00779 DRAWING NO: 2837397 SHEET 4 OF 4 REV A