

| ATLANTIC VERSION TERMINATOR INTERFACE ADAPTER | PART NUMBER | REVISION | DESCRIPTION | FEED TYPE | |
|---|-------------|----------|--------------------------|-------------------|---------------------------|
| | 2836638-1 | A | FINE CRIMP HEIGHT ADJUST | MECHANICAL | SUPERSEDED BY 5-2151470-1 |
| | 2836638-2 | A | FINE CRIMP HEIGHT ADJUST | PNEUMATIC | SUPERSEDED BY 5-2151470-2 |
| | 2836638-5 | A | FINE CRIMP HEIGHT ADJUST | SERVO LATCH PLATE | OBSOLETE |
| | 2836638-6 | A | NON CRIMP HEIGHT ADJUST | SERVO LATCH PLATE | OBSOLETE |
| | 2836638-7 | A | FINE CRIMP HEIGHT ADJUST | NONE | OBSOLETE |
| | 7-2836638-7 | A | CRIMP TOOLING KIT | - | |

| APPLICATOR DATA | | |
|-----------------|----------------|------|
| CRIMP | SIZE | TYPE |
| WIRE | 1.27 mm [.050] | F |
| INSUL | 1.78 mm [.070] | O |

APPLICATOR INSTRUCTIONS
408-10389

| TERMINAL DATA: TE TERMINAL | | TE CRIMP SPECIFICATION | |
|--|-------------|------------------------------|-------------|
| TERMINAL NAME: 1.2MM CONTACT ASSEMBLY (CLEAN BODY) | | | |
| WIRE STRIP LENGTH | | INSULATION DIAMETER RANGE | |
| 2.60-3.20 mm [.102-.126 IN] | | Ø1.10-1.75 mm [.043-.069 IN] | |
| TERMINAL APPLICATION SPECIFICATION | 114-18464 | | |
| TERMINALS APPLIED | | | |
| TE TERMINAL | TE TERMINAL | TE TERMINAL | TE TERMINAL |
| 1534594-1 | 1534594-2 | 1534594-3 | |

| WIRE SIZE | CRIMP HEIGHT mm [INCH] | CRIMP HEIGHT REFERENCE SETTING |
|-----------|----------------------------|--------------------------------|
| 0.35mm2 | 0.87+/-0.03 [.034+/-0.001] | 7.9 |
| 22 AWG | 0.86+/-0.03 [.034+/-0.001] | 8.0 |
| 24 AWG | 0.80+/-0.03 [.031+/-0.001] | 8.6 |

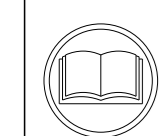

- 1. RECOMMENDED SPARE PARTS
- 2. GREASE BEARING SURFACES LIGHTLY
- 3. LUBRICATE DAILY PER THE APPLICATOR INSTRUCTION SHEET SUPPLIED WITH THE APPLICATOR.
- 4. APPLICATOR SPECIFIC DATA TO BE ENTERED INTO BLANK MEMORY CHIP AT ASSEMBLY. SEE BELOW FOR PART NUMBER:
MECHANICAL FEED WITH "SMART APPLICATOR" CONVERSION: 8-2836638-4
PNEUMATIC FEED WITH "SMART APPLICATOR" CONVERSION: 8-2836638-4
SERVO FEED WITH "FINE CRIMP HEIGHT ADJUST": 8-2836638-5
SERVO FEED WITH "NON-CRIMP HEIGHT ADJUST": 8-2836638-6
- 5. ADJUSTMENT OF THE STRIPPER MAY BE REQUIRED WHEN MOVING THE APPLICATOR BETWEEN BENCH AND LEADMAKER APPLICATIONS.
- 6. APPLY PART NUMBER 1-23419-5 LOCTITE TO THREADS OF ITEMS 62 & 180. APPLY PART NUMBER 2-23419-6 LOCTITE TO THREADS OF ITEMS 242. FOR -6 ONLY APPLY PART NUMBER 1-23419-5 LOCTITE TO THREADS OF ITEMS 37 & 180.
- 7. GREASE THREADS, GROOVE AND O-RING ON ITEMS 35 & 252.
- 8. MAGNET, ITEM 166 MUST BE ORIENTED CORRECTLY IN ORDER TO PROPERLY ACTUATE THE COUNTER.
- 9. CRIMP HEIGHT REFERENCE SETTING WAS THE SETTING USED WHEN THE APPLICATOR WAS QUALIFIED AT THE FACTORY. ADJUSTMENT MAY BE NECESSARY WHEN RUNNING APPLICATOR IN THE FIELD.
- 10. SPARE FEED CAM STORAGE LOCATION REFER TO INSTRUCTION SHEET FOR ADDITIONAL INFORMATION.
- 11. TO CONVERT THE APPLICATOR TO A NON-CARRIER CUTTING STYLE, REMOVE ITEM 13 AND ATTACH TO THE LOCATION ON THE BACK SIDE OF THE HOUSING. REFER TO INSTRUCTION SHEET FOR ADDITIONAL INFORMATION.
- 12. WHEN ASSEMBLING -6 NON-CRIMP HEIGHT ADJUST APPLICATOR USE SHIM PACK 2119957-2 TO ALIGN APPLICATOR'S MAXIMUM WIRE CRIMP HEIGHT AT NORMAL TERMINATOR SHUT HEIGHT.
- 13. THIS APPLICATOR IS SPECIFIC FOR USE IN A STRIPPER SEAL TERMINATING UNIT.
- 14. TERMINAL LUBRICANT IS RECOMMENDED.

***WARNING**
ON INSTALLATION, SET WIRE DISC, ITEM 40 TO LARGEST WIRE SIZE SETTING. USE OF SETTINGS BELOW MINIMUM REQUIRED CRIMP HEIGHT SETTING WILL CAUSE DAMAGE TO CRIMP TOOLING.

| | | | | | | | | |
|-----|----|----|----|----|----|-----------|---------------------------------|---------|
| - | - | 1 | - | - | - | 2119957-2 | APPLICATOR SHIM PACK | 260 |
| - | 1 | - | 1 | 1 | 1 | 8-21084-0 | O-RING, .676 ID, .070 DIA. MAT. | 252 |
| - | - | - | - | 1 | - | 2119640-1 | PUSH ROD, AIR FEED | 250 |
| - | - | - | - | 1 | - | 1803259-1 | BUSHING, FLANGED | 249 |
| - | - | - | - | 1 | - | 2119641-1 | FEED CAM, AIR FEED | 248 |
| -77 | -7 | -6 | -5 | -2 | -1 | PART NO | DESCRIPTION | ITEM NO |

ATLANTIC VERSION
Shown on sheets 1 of 4 & 2 of 4
(Pacific version shown on sheets 3 of 4 & 4 of 4)

| SET UP GAUGE | LOC | DIST | REVISIONS | | | |
|--------------|-----|------|-----------|---------------|-----------|---------|
| 2119599-1 | A | 66 | # | DATE | BY | APPV |
| | | | A | RELEASED | 09MAR2017 | TB TE |
| | | | A1 | ECR-18-005129 | 20APR2018 | JAH JGG |

| | | | | | | | | |
|-----|-----|-----|-----|-----|-----|-------------|-------------------------------------|---------|
| - | 1 | - | 1 | 1 | 1 | 2119798-1 | DETENT PIN | 247 |
| - | 1 | - | 1 | 1 | 1 | 1-22279-3 | SPRING, COMPRESSION | 246 |
| - | - | 1 | - | - | - | 2119758-1 | RAM, AMP STYLE, SIDE FEED, NON-ADJ. | 245 |
| - | 1 | 1 | 1 | 1 | 1 | 2119082-5 | CAM, SNAIL, INSULATION ADJUSTMENT | 244 |
| - | 1 | 1 | 1 | 1 | 1 | 2079764-1 | WASHER, WAVE SPRING, CREST-TO-CREST | 243 |
| 6 | - | 1 | 1 | 1 | 1 | 2119083-1 | RETAINER, INSULATION DIAL | 242 |
| - | 1 | 1 | 1 | 1 | 1 | 7-18023-7 | SCR, SKT HD CAP M3 X 4.0 | 241 |
| - | - | 2 | 2 | - | - | 2168400-6 | SHCS, LOW HEAD, RoHS, M5 X 16 | 240 |
| - | - | - | - | - | 1 | 2119580-1 | MECHANICAL FEED ASSEMBLY | 239 |
| - | - | - | - | 1 | - | 2063440-1 | AIR FEED MODULE | 238 |
| - | - | 1 | 1 | - | - | 2119740-2 | TAG, IDENTIFICATION | 213 |
| - | - | 1 | 1 | - | - | 1901094-3 | SPACER, FEEDER | 198 |
| - | 1 | 1 | 1 | 1 | 1 | 4-1722335-3 | STRIPPER, SIDE FEED | 182 |
| 6 | - | 1 | 1 | 1 | 1 | 1-5018030-0 | NUT, HEX, REG, RoHS, M3.5 | 181 |
| - | 1 | 1 | 1 | 1 | 1 | 1-1752354-7 | STANDOFF, HOLD-DOWN | 180 |
| - | 1 | 1 | 1 | 1 | 1 | 993111-1 | PIN, SLOTTED SPRING 3.0 X 20.0 | 177 |
| - | 1 | 1 | 1 | 1 | 1 | 5-22280-0 | SPRING, COMPRESSION | 176 |
| - | 1 | 1 | 1 | 1 | 1 | 1752353-3 | GUIDE PIN, HOLDDOWN | 175 |
| - | 1 | 1 | 1 | 1 | 1 | 1901680-2 | GUIDE PIN, HOLDDOWN | 174 |
| - | - | - | - | 2 | - | 21045-3 | RING, RETAIN, EXTERN, 3/16 CRESCENT | 172 |
| 8 | - | 1 | 1 | 1 | 1 | 994969-1 | MAGNET, RARE EARTH HIGH ENERGY | 166 |
| - | REF | REF | REF | REF | REF | 994970-2 | COUNTER, MAGNETIC | 164 |
| - | - | - | - | 1 | - | 240638-1 | SPRING, FEED FINGER | 163 |
| - | - | - | - | 1 | - | 3-23627-7 | PIN, RETAIN, GRVD, 3/16 X .854 | 137 |
| - | - | - | - | 1 | - | 2119799-1 | HOLDER, FEED FINGER, AF | 136 |
| 4 | - | REF | REF | - | - | SEE NOTE 4 | MEMORY CHIP, PROGRAMMED | 135 |
| - | - | 1 | 1 | - | - | 1633743-1 | SERVO FEED LATCH ASM | 133 |
| - | 1 | 1 | 1 | 1 | 1 | 1-18028-2 | WASHER, FLAT, REG M4 | 119 |
| - | - | REF | REF | - | - | 2119944-1 | FEED FINGER ASSEMBLY, SF | 117 |
| 14 | - | 1 | 1 | 1 | 1 | 2119955-1 | ASSY, LUBRICATOR, SIDE FEED | 113 |
| - | 1 | 1 | 1 | 1 | 1 | 455888-5 | SPACER, CRIMPER | 82 |
| - | 1 | 1 | 1 | 1 | 1 | 2119956-1 | DOCUMENTATION PACKAGE | 71 |
| - | 1 | 1 | 1 | 1 | 1 | 2119791-5 | DEPRESSOR, WIRE | 70 |
| - | 1 | - | - | 1 | 1 | 2119740-1 | TAG, IDENTIFICATION | 67 |
| - | 2 | 2 | 2 | 2 | 2 | 2168078-1 | SCREW, DRIVE, RH, RoHS, 2 x .188 | 66 |
| - | 1 | - | 1 | 1 | 1 | 2119793-1 | LIMITER, ADJUSTMENT BOLT | 63 |
| 6 | - | 3 | - | 3 | 3 | 992763-5 | SCR, SET, SOC, CONE PNT, M3 X 4.0 | 62 |
| - | 1 | 1 | 1 | 1 | 1 | 2079383-4 | SCR, BHSC, RoHS (M4 X 8) | 60 |
| - | - | - | - | 1 | 1 | 5-18022-5 | SCR, HEX HD CAP, M4 X 6.0 | 59 |
| - | - | - | - | 1 | 1 | 1338685-1 | PAWL, FEED | 56 |
| - | 4 | 4 | 4 | 4 | 4 | 2168400-1 | SHCS, LOW HEAD, RoHS, M4 X 12 | 54 |
| - | 2 | 2 | 2 | 2 | 2 | 2-2168083-5 | SCR, SKT HD CAP, RoHS, M4 X 14 | 53 |
| - | 1 | 1 | 1 | 1 | 1 | 5018030-1 | NUT, HEX, REG, RoHS, M3 | 52 |
| - | 1 | 1 | 1 | 1 | 1 | 811242-5 | BUMPER, HOLD DOWN | 51 |
| - | 1 | 1 | 1 | 1 | 1 | 690753-2 | SPACER, TONKER | 50 |
| - | - | - | - | 1 | 2 | 18023-9 | SCR, SKT HD CAP M4 X 6.0 | 49 |
| - | - | - | - | - | 1 | 2119652-1 | FEED CAM, PRE FEED | 48 |
| - | - | - | - | - | 1 | 2119653-1 | FEED CAM, POST FEED | 47 |
| - | 1 | 1 | 1 | 1 | 1 | 2-2119656-1 | APPLICATOR BASIC ASSEMBLY, SF | 46 |
| - | 1 | - | 1 | 1 | 1 | 2119370-1 | RAM, AMP STYLE, SIDE FEED | 44 |
| - | 1 | 1 | 1 | 1 | 1 | 2079383-7 | SCR, BHSC, RoHS (M8 X 25) | 41 |
| - | 1 | - | 1 | 1 | 1 | 2119645-1 | DISC, NUMBERED FA WIRE ADJUSTMENT | 40 |
| - | 1 | - | 1 | 1 | 1 | 2119957-1 | APPLICATOR SHIM PACK | 39 |
| - | 1 | 1 | 1 | 1 | 1 | 2119644-1 | RAM WASHER, PRECISION | 38 |
| 6 | - | 1 | 1 | 1 | 1 | 2119085-1 | FA HEAD, ATLANTIC STYLE | 37 |
| 7 | - | 1 | - | 1 | 1 | 2119092-1 | BOLT, ADJUSTMENT | 35 |
| - | 1 | 1 | 1 | 1 | 1 | 1752356-6 | SUPPORT, TERMINAL | 34 |
| - | 2 | 2 | 2 | 2 | 2 | 2079383-5 | SCR, BHSC, RoHS (M4 X 20) | 33 |
| - | 1 | 1 | 1 | 1 | 1 | 2161328-1 | HEX HEAD, FLANGED, M5 X 8mm LONG | 32 |
| - | 1 | 1 | 1 | 1 | 1 | 1320908-3 | SPACER, STRIP GUIDE | 30 |
| - | 1 | 1 | 1 | 1 | 1 | 2119959-2 | ASSEMBLY, STRIP GUIDE | 29 |
| - | 1 | 1 | 1 | 1 | 1 | 1320928-2 | STRIP GUIDE | 24 |
| 1 | - | 1 | 1 | 1 | 1 | 2119806-1 | INSERT, SHEAR | 13 |
| - | 1 | 1 | 1 | 1 | 1 | 3-22280-3 | SPRING, COMPRESSION | 12 |
| - | 1 | 1 | 1 | 1 | 1 | 1-356885-4 | STOP, SHEAR | 11 |
| 1 | - | 1 | 1 | 1 | 1 | 2119805-1 | SHEAR HOLDER, FRONT | 10 |
| 1 | - | 1 | 1 | 1 | 1 | 1803095-3 | FLOATING SHEAR, FRONT | 9 |
| 1 | 1 | 1 | 1 | 1 | 1 | 2-1333225-0 | ANVIL, COMBINATION | 8 |
| - | 1 | 1 | 1 | 1 | 1 | 240641-5 | SPACER | 7 |
| - | 1 | 1 | 1 | 1 | 1 | 2119757-8 | DEPRESSOR, SHEAR | 5 |
| - | 1 | 1 | 1 | 1 | 1 | 238011-4 | BLOCK, CRIMPER SPACER | 4 |
| 1 | 1 | 1 | 1 | 1 | 1 | 1633965-8 | CRIMPER, INSULATION O PREMIUM | 3 |
| - | 1 | 1 | 1 | 1 | 1 | 455888-3 | SPACER, CRIMPER | 2 |
| 1 | 1 | 1 | 1 | 1 | 1 | 1-1673600-0 | CRIMPER, WIRE | 1 |
| -77 | -7 | -6 | -5 | -2 | -1 | PART NO | DESCRIPTION | ITEM NO |

| DIMENSIONS: | | TOLERANCES UNLESS OTHERWISE SPECIFIED: | | OWN | CHK | DATE | NAME | |
|-------------|---------|--|---------|--------------|----------|-----------|--|--|
| mm | 0 PLC ± | 1 PLC ± | 2 PLC ± | M. ZHAO | K. ZHANG | 27FEB2017 | Ocean Side Feed Applicator | |
| | 3 PLC ± | 4 PLC ± | 5 PLC ± | | | | Customer Accessible Production Drawing | |
| MATERIAL | FINISH | WEIGHT | SCALE | SHEET 1 OF 4 | | REV A1 | | |

| LOC | DIST | REVISIONS | | | |
|-----|------|-------------|------|-----|------|
| A | 66 | REV | DATE | OWN | APVD |
| - | - | SEE SHEET 1 | - | - | - |

FEED TYPE MECHANICAL

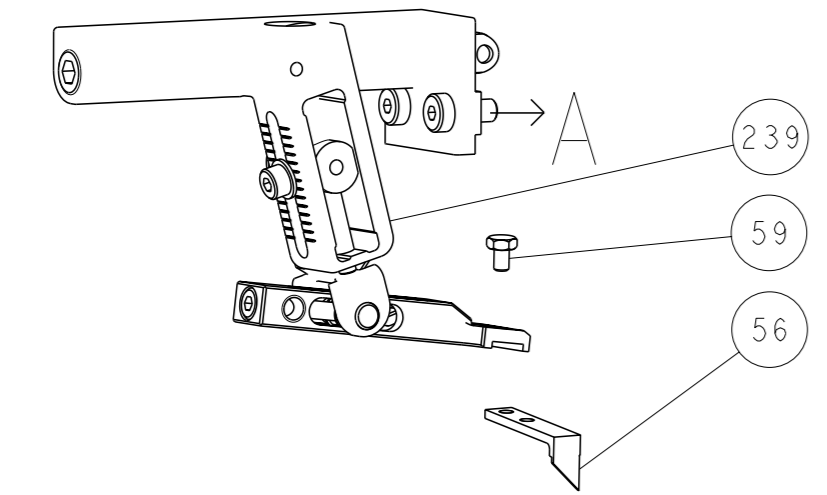

PNEUMATIC

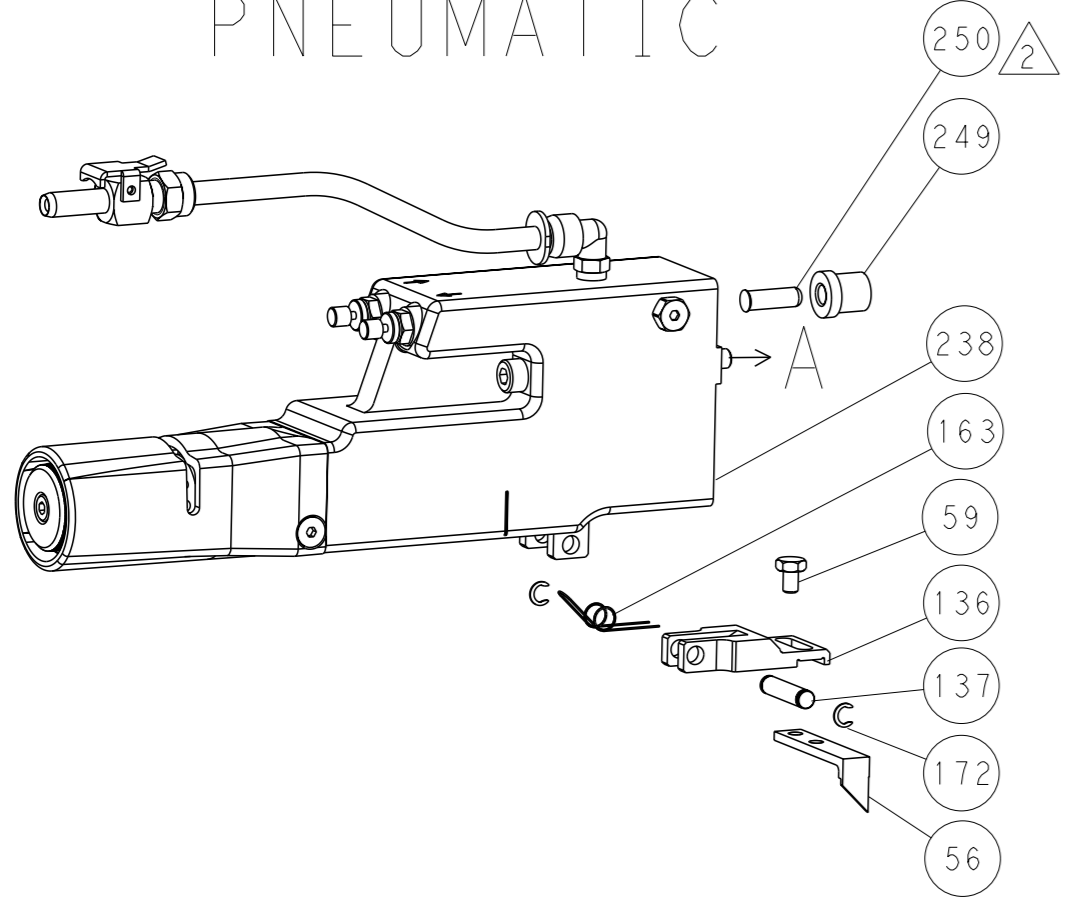

SERVO LATCH PLATE

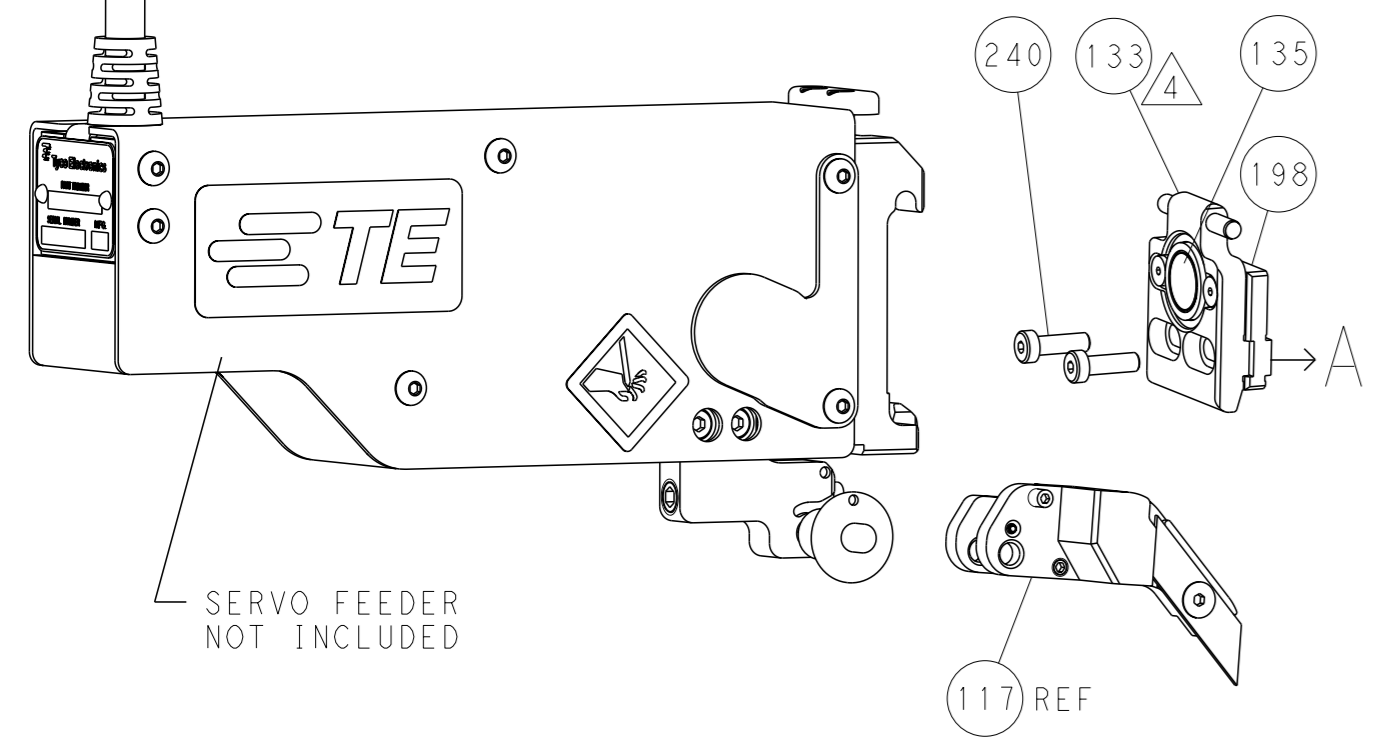

CAM POSITIONS

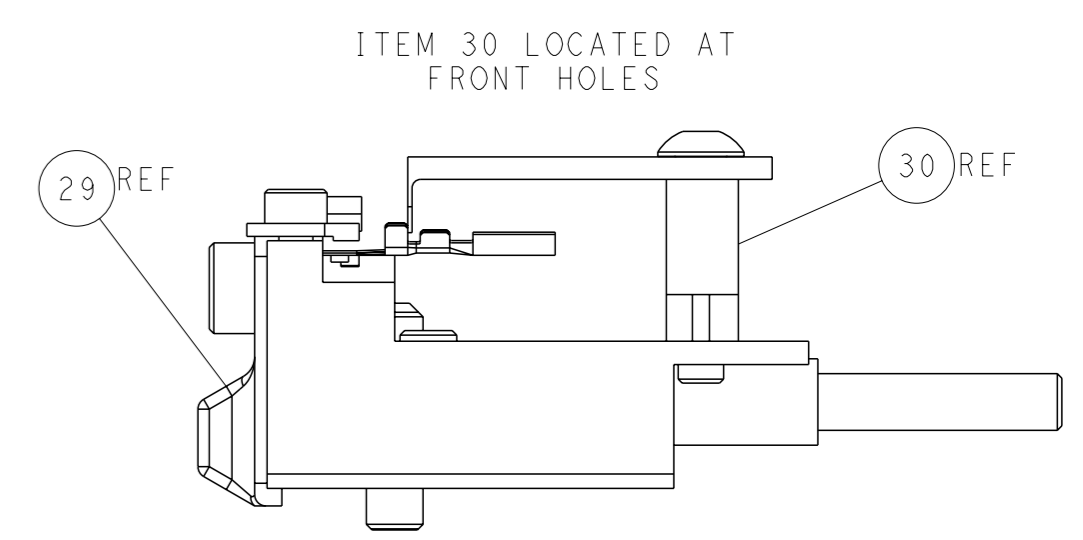
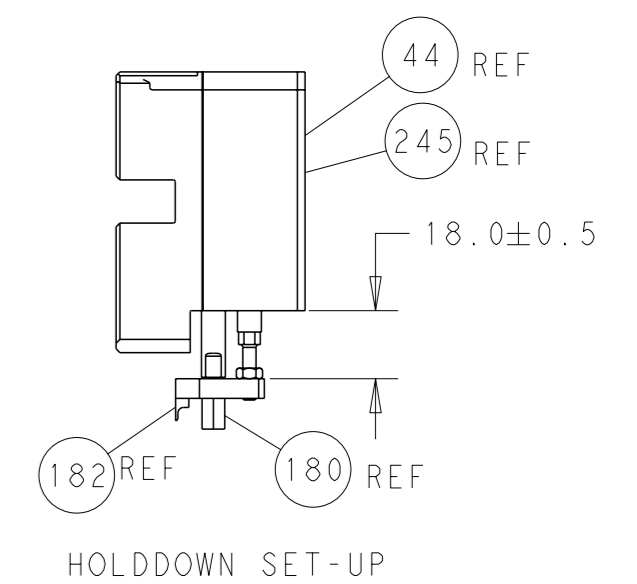
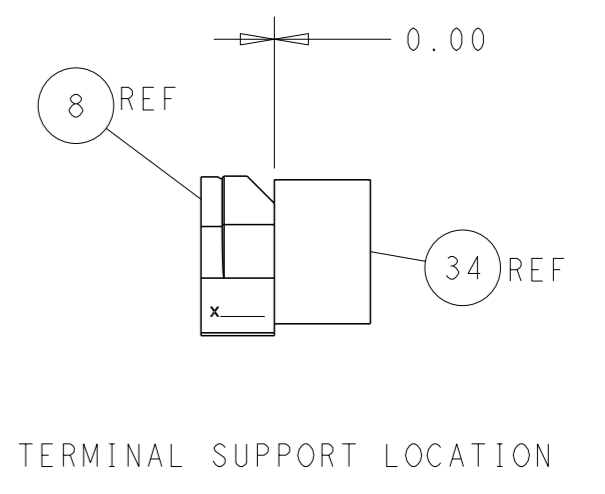
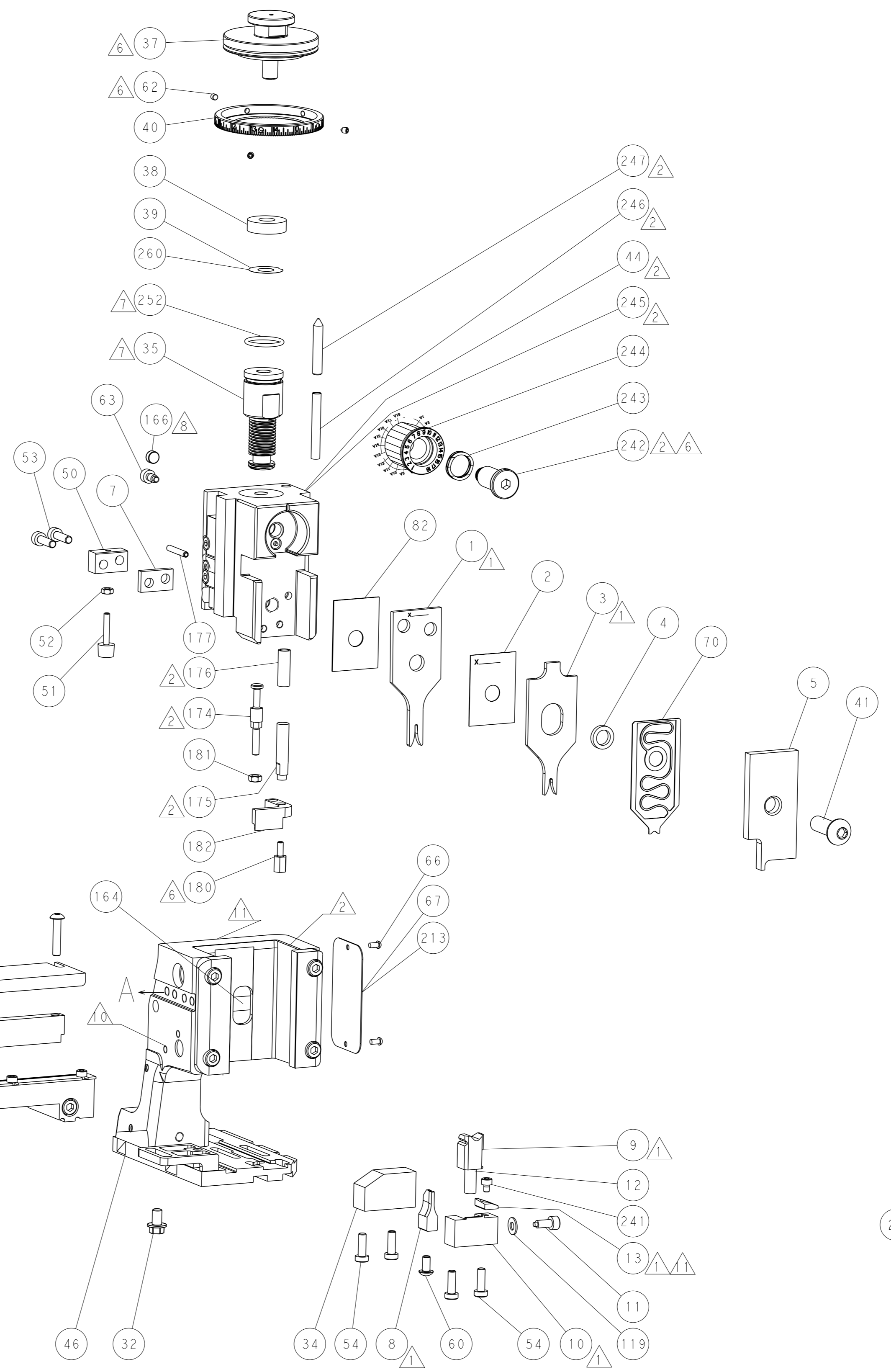
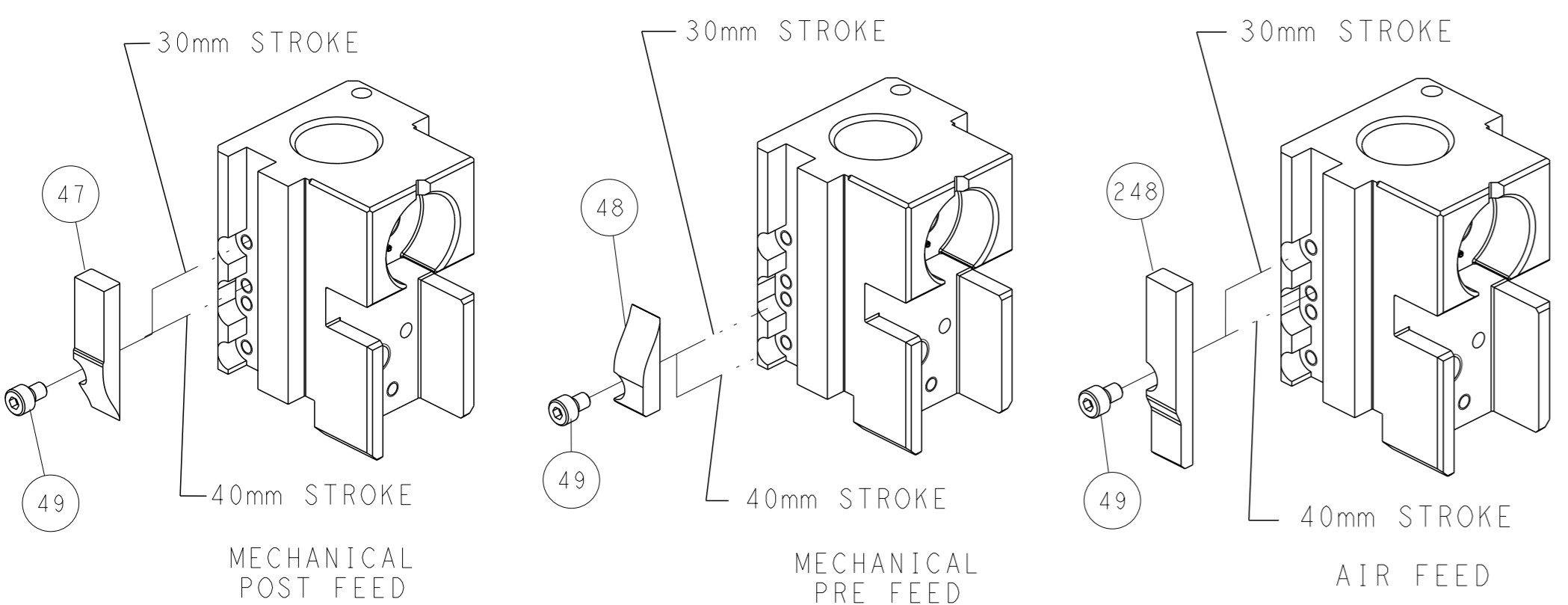

ATLANTIC VERSION
 Shown on sheets 1 of 4 & 2 of 4
 (Pacific version shown on sheets 3 of 4 & 4 of 4)

| | | | |
|---|-----------|---|---|
| <small>THIS DRAWING IS A CONTROLLED DOCUMENT FOR TYCO ELECTRONICS CORPORATION. IT IS SUBJECT TO CHANGE AND THE CONTROL AND REVISIONS DISPOSITION SHOULD BE CONTACTED FOR THE LATEST REVISION.</small> | | OWN: M. ZHAO 27FEB2017 CHK: K. ZHANG 27FEB2017 APVD: K. ZHANG 27FEB2017 | NAME: Ocean Side Feed Applicator SIZE: A1 CAGE CODE: 00779 DRAWING NO: 2836638 SCALE: 1:2 SHEET: 2 of 4 REV: A1 |
| DIMENSIONS: mm TOLERANCES UNLESS OTHERWISE SPECIFIED: 0 PLC ± 1 PLC ± 2 PLC ± 3 PLC ± 4 PLC ± ANGLES ° ± | MATERIAL: | WEIGHT: | RESTRICTED TO: |

| PACIFIC VERSION TERMINATOR INTERFACE ADAPTER | PART NUMBER | REVISION | DESCRIPTION | FEED TYPE | |
|--|-------------|----------|--------------------------|-------------------|----------|
| | 2-2836638-1 | A | FINE CRIMP HEIGHT ADJUST | MECHANICAL | OBSOLETE |
| | 2-2836638-2 | A | FINE CRIMP HEIGHT ADJUST | PNEUMATIC | OBSOLETE |
| | 2-2836638-5 | A | FINE CRIMP HEIGHT ADJUST | SERVO LATCH PLATE | OBSOLETE |
| | 2-2836638-7 | A | FINE CRIMP HEIGHT ADJUST | NONE | OBSOLETE |
| | 7-2836638-7 | A | CRIMP TOOLING KIT | - | |

| APPLICATOR DATA | | |
|-----------------------------------|----------------|------|
| CRIMP | SIZE | TYPE |
| WIRE | 1.27 mm (.050) | F |
| INSUL | 1.78 mm (.070) | O |
| APPLICATOR INSTRUCTIONS 408-10389 | | |

| TERMINAL DATA: TE TERMINAL | | TE CRIMP SPECIFICATION | |
|--|-------------|------------------------------|-------------|
| TERMINAL NAME: 1.2MM CONTACT ASSEMBLY (CLEAN BODY) | | | |
| WIRE STRIP LENGTH | | INSULATION DIAMETER RANGE | |
| 2.60-3.20 mm (.102-.126 IN) | | Ø1.10-1.75 mm (.043-.069 IN) | |
| TERMINAL APPLICATION SPECIFICATION | 114-18464 | | |
| TERMINALS APPLIED | | | |
| TE TERMINAL | TE TERMINAL | TE TERMINAL | TE TERMINAL |
| 1534594-1 | 1534594-2 | 1534594-3 | |

| WIRE SIZE | CRIMP HEIGHT mm [INCH] | CRIMP HEIGHT REFERENCE SETTING |
|-----------|----------------------------|--------------------------------|
| 0.35mm2 | 0.87+/-0.03 [.034+/-0.001] | 7.9 |
| 22 AWG | 0.86+/-0.03 [.034+/-0.001] | 8.0 |
| 24 AWG | 0.80+/-0.03 [.031+/-0.001] | 8.6 |

- 1 RECOMMENDED SPARE PARTS
- 2 GREASE BEARING SURFACES LIGHTLY
- 3 LUBRICATE DAILY PER THE APPLICATOR INSTRUCTION SHEET SUPPLIED WITH THE APPLICATOR.
- 4 APPLICATOR SPECIFIC DATA TO BE ENTERED INTO BLANK MEMORY CHIP AT ASSEMBLY. SEE BELOW FOR PART NUMBER:
 MECHANICAL FEED WITH "SMART APPLICATOR" CONVERSION: 8-2836638-4
 PNEUMATIC FEED WITH "SMART APPLICATOR" CONVERSION: 8-2836638-4
 SERVO FEED WITH "FINE CRIMP HEIGHT ADJUST": 8-2836638-5
- 5 ADJUSTMENT OF THE STRIPPER MAY BE REQUIRED WHEN MOVING THE APPLICATOR BETWEEN BENCH AND LEADMAKER APPLICATIONS.
- 6 APPLY PART NUMBER 1-23419-5 LOCTITE TO THREADS OF ITEMS 62 & 180. APPLY PART NUMBER 2-23419-6 LOCTITE TO THREADS OF ITEMS 242.
- 7 GREASE THREADS, GROOVE AND O-RING ON ITEMS 139 & 152.
- 8 MAGNET MUST BE ORIENTED CORRECTLY IN ORDER TO PROPERLY ACTUATE THE COUNTER.
- 9 CRIMP HEIGHT REFERENCE SETTING WAS THE SETTING USED WHEN THE APPLICATOR WAS QUALIFIED AT THE FACTORY. ADJUSTMENT MAY BE NECESSARY WHEN RUNNING APPLICATOR IN THE FIELD.
- 10 SPARE FEED CAM STORAGE LOCATION REFER TO INSTRUCTION SHEET FOR ADDITIONAL INFORMATION.
- 11 TO CONVERT THE APPLICATOR TO A NON-CARRIER CUTTING STYLE, REMOVE ITEM 13 AND ATTACH TO THE LOCATION ON BACK SIDE OF THE HOUSING. REFER TO INSTRUCTION SHEET FOR ADDITIONAL INFORMATION.
- 12 THIS APPLICATOR IS SPECIFIC FOR USE IN A STRIPPER SEAL TERMINATING UNIT.
- 13 TERMINAL LUBRICANT IS RECOMMENDED.

***WARNING**
 ON INSTALLATION, SET WIRE DISC, ITEM 40 TO LARGEST WIRE SIZE SETTING. USE OF SETTINGS BELOW MINIMUM REQUIRED CRIMP HEIGHT SETTING WILL CAUSE DAMAGE TO CRIMP TOOLING.

| | | | | | | | |
|-----|-----|-----|-----|-----|-----------|-------------------------------------|---------|
| - | 1 | 1 | 1 | 1 | 2119782-1 | FINE ADJUST HEAD ASM, PACIFIC STYLE | 251 |
| - | - | - | 1 | - | 2119640-1 | PUSH ROD, AIR FEED | 250 |
| - | - | - | 1 | - | 1803259-1 | BUSHING, FLANGED | 249 |
| - | 1 | 1 | 1 | 1 | 1-22279-3 | SPRING, COMPRESSION | 246 |
| -77 | -27 | -25 | -22 | -21 | PART NO | DESCRIPTION | ITEM NO |

PACIFIC VERSION
 Shown on sheets 3 of 4 & 4 of 4
 (Atlantic version shown on sheets 1 of 4 & 2 of 4)

| SET UP GAUGE | LOC | DIST | REVISIONS | | | |
|--------------|-----|------|-----------|-------------|----|------|
| 2119599-1 | A | 66 | # | DATE | BY | APPV |
| | | | - | SEE SHEET 1 | - | - |

| | | | | | | | |
|-----|-----|-----|-----|-----|-------------|-------------------------------------|---------|
| - | 1 | 1 | 1 | 1 | 2119082-5 | CAM, SNAIL, INSULATION ADJUSTMENT | 244 |
| - | 1 | 1 | 1 | 1 | 2079764-1 | WASHER, WAVE SPRING, CREST-TO-CREST | 243 |
| 6 | - | 1 | 1 | 1 | 2119083-1 | RETAINER, INSULATION DIAL | 242 |
| - | 1 | 1 | 1 | 1 | 7-18023-7 | SCR, SKT HD CAP M3 X 4.0 | 241 |
| - | - | 2 | - | - | 2168400-6 | SHCS, LOW HEAD, RoHS, M5 X 16 | 240 |
| - | - | - | - | 1 | 2119580-1 | MECHANICAL FEED ASSEMBLY | 239 |
| - | - | - | 1 | - | 2063440-1 | AIR FEED MODULE | 238 |
| - | - | 1 | - | - | 2119740-2 | TAG, IDENTIFICATION | 213 |
| - | - | 1 | - | - | 1901094-3 | SPACER, FEEDER | 198 |
| - | 1 | 1 | 1 | 1 | 4-1722335-3 | STRIPPER, SIDE FEED | 182 |
| - | 1 | 1 | 1 | 1 | 1-5018030-0 | NUT, HEX, REG, RoHS, M3.5 | 181 |
| 6 | - | 1 | 1 | 1 | 1-1752354-7 | STANDOFF, HOLD-DOWN | 180 |
| - | 1 | 1 | 1 | 1 | 993111-1 | PIN, SLOTTED SPRING 3.0 X 20.0 | 177 |
| - | 1 | 1 | 1 | 1 | 5-22280-0 | SPRING, COMPRESSION | 176 |
| - | 1 | 1 | 1 | 1 | 1752353-3 | GUIDE PIN, HOLDDOWN | 175 |
| - | 1 | 1 | 1 | 1 | 1901680-2 | GUIDE PIN, HOLDDOWN | 174 |
| - | - | - | 2 | - | 21045-3 | RING, RETAIN, EXTERN, 3/16 CRESCENT | 172 |
| 8 | - | 1 | 1 | 1 | 994969-1 | MAGNET, RARE EARTH HIGH ENERGY | 166 |
| - | REF | REF | REF | REF | 994970-2 | COUNTER, MAGNETIC | 164 |
| - | - | - | 1 | - | 240638-1 | SPRING, FEED FINGER | 163 |
| 7 | - | 1 | 1 | 1 | 8-21084-1 | O-RING, .801 ID, .070 DIA. MAT. | 152 |
| - | - | - | 1 | - | 2119641-2 | FEED CAM, AIR FEED | 151 |
| - | 1 | 1 | 1 | 1 | 2119798-2 | DETENT PIN | 145 |
| - | 1 | 1 | 1 | 1 | 2079383-8 | SCR, BHSC, RoHS (M4 X 16) | 144 |
| - | 4 | 4 | 4 | 4 | 2168400-5 | SHCS, LOW HEAD, RoHS, M4 X 20 | 143 |
| - | - | - | - | 1 | 2119653-2 | FEED CAM, POST FEED | 142 |
| - | 1 | 1 | 1 | 1 | 2-2119656-2 | APPLICATOR BASIC ASSEMBLY, SF | 141 |
| - | 1 | 1 | 1 | 1 | 2119650-1 | RAM, ASIAN STYLE, SIDE FEED | 140 |
| 7 | - | 1 | 1 | 1 | 2119092-2 | BOLT, ADJUSTMENT | 139 |
| - | - | - | 1 | - | 3-23627-7 | PIN, RETAIN, GRVD, 3/16 X .854 | 137 |
| - | - | - | 1 | - | 2119799-1 | HOLDER, FEED FINGER, AF | 136 |
| 4 | - | REF | - | - | SEE NOTE 4 | MEMORY CHIP, PROGRAMMED | 135 |
| - | - | 1 | - | - | 1633743-1 | SERVO FEED LATCH ASM | 133 |
| - | 1 | 1 | 1 | 1 | 1-18028-2 | WASHER, FLAT, REG M4 | 119 |
| - | - | REF | - | - | 2119944-1 | FEED FINGER ASSEMBLY, SF | 117 |
| 3 | - | 1 | 1 | 1 | 2119955-1 | ASSY, LUBRICATOR, SIDE FEED | 113 |
| - | 1 | 1 | 1 | 1 | 455888-5 | SPACER, CRIMPER | 82 |
| - | 1 | 1 | 1 | 1 | 2119956-1 | DOCUMENTATION PACKAGE | 71 |
| - | 1 | 1 | 1 | 1 | 2119791-5 | DEPRESSOR, WIRE | 70 |
| - | 1 | - | 1 | 1 | 2119740-1 | TAG, IDENTIFICATION | 67 |
| - | 2 | 2 | 2 | 2 | 2168078-1 | SCREW, DRIVE, RH, RoHS, 2 x .188 | 66 |
| - | 1 | 1 | 1 | 1 | 2119793-1 | LIMITER, ADJUSTMENT BOLT | 63 |
| 6 | - | 3 | 3 | 3 | 992763-5 | SCR, SET, SOC, CONE PNT, M3 X 4.0 | 62 |
| - | - | - | 1 | 1 | 5-18022-5 | SCR, HEX HD CAP, M4 X 6.0 | 59 |
| - | - | - | 1 | 1 | 1338685-1 | PAWL, FEED | 56 |
| - | 2 | 2 | 2 | 2 | 2-2168083-5 | SCR, SKT HD CAP, RoHS, M4 X 14 | 53 |
| - | 1 | 1 | 1 | 1 | 5018030-1 | NUT, HEX, REG, RoHS, M3 | 52 |
| - | 1 | 1 | 1 | 1 | 811242-5 | BUMPER, HOLD DOWN | 51 |
| - | 1 | 1 | 1 | 1 | 690753-2 | SPACER, TONKER | 50 |
| - | - | - | 1 | 2 | 18023-9 | SCR, SKT HD CAP M4 X 6.0 | 49 |
| - | - | - | - | 1 | 2119652-1 | FEED CAM, PRE FEED | 48 |
| - | 1 | 1 | 1 | 1 | 2079383-7 | SCR, BHSC, RoHS (M8 X 25) | 41 |
| - | 1 | 1 | 1 | 1 | 2119645-1 | DISC, NUMBERED FA WIRE ADJUSTMENT | 40 |
| - | 1 | 1 | 1 | 1 | 2119957-1 | APPLICATOR SHIM PACK | 39 |
| - | 1 | 1 | 1 | 1 | 2119644-1 | RAM WASHER, PRECISION | 38 |
| - | 1 | 1 | 1 | 1 | 1752356-6 | SUPPORT, TERMINAL | 34 |
| - | 2 | 2 | 2 | 2 | 2079383-5 | SCR, BHSC, RoHS (M4 X 20) | 33 |
| - | 1 | 1 | 1 | 1 | 2161328-1 | HEX HEAD, FLANGED, M5 X 8mm LONG | 32 |
| - | 1 | 1 | 1 | 1 | 1320908-3 | SPACER, STRIP GUIDE | 30 |
| - | 1 | 1 | 1 | 1 | 2119959-2 | ASSEMBLY, STRIP GUIDE | 29 |
| - | 1 | 1 | 1 | 1 | 1320928-2 | STRIP GUIDE | 24 |
| 11 | - | 1 | 1 | 1 | 2119806-1 | INSERT, SHEAR | 13 |
| - | 1 | 1 | 1 | 1 | 3-22280-3 | SPRING, COMPRESSION | 12 |
| - | 1 | 1 | 1 | 1 | 1-356885-4 | STOP, SHEAR | 11 |
| 1 | - | 1 | 1 | 1 | 2119805-1 | SHEAR HOLDER, FRONT | 10 |
| 1 | - | 1 | 1 | 1 | 1803095-3 | FLOATING SHEAR, FRONT | 9 |
| 1 | 1 | 1 | 1 | 1 | 2-1333225-0 | ANVIL, COMBINATION | 8 |
| - | 1 | 1 | 1 | 1 | 240641-5 | SPACER | 7 |
| - | 1 | 1 | 1 | 1 | 2119757-8 | DEPRESSOR, SHEAR | 5 |
| - | 1 | 1 | 1 | 1 | 238011-4 | BLOCK, CRIMPER SPACER | 4 |
| 1 | 1 | 1 | 1 | 1 | 1633965-8 | CRIMPER, INSULATION O PREMIUM | 3 |
| - | 1 | 1 | 1 | 1 | 455888-3 | SPACER, CRIMPER | 2 |
| 1 | 1 | 1 | 1 | 1 | 1-1673600-0 | CRIMPER, WIRE | 1 |
| -77 | -27 | -25 | -22 | -21 | PART NO | DESCRIPTION | ITEM NO |

| DIMENSIONS: | | TOLERANCES UNLESS OTHERWISE SPECIFIED: | | OWN | CHK | APPV | DATE | NAME | |
|-------------|----------|--|-----------------|-----------------|----------|----------|-----------|----------------------------|------------|
| mm | 0 PLC ± | 1 PLC ± | 2 PLC ± | M. ZHAO | K. ZHANG | K. ZHANG | 27FEB2017 | Ocean Side Feed Applicator | |
| | 3 PLC ± | 4 PLC ± | ANGLES FINISH * | APPLICATOR SPEC | | SIZE | | CAGE CODE | DRAWING NO |
| MATERIAL | WEIGHT | | RESTRICTED TO | | SCALE | | SHEET | | REV |
| | A1 00779 | | C=2836638 | | 1:2 | | 3 of 4 | | A1 |

