

PART NUMBER	REVISION	DESCRIPTION	FEED TYPE
2836535-1	C	FINE CRIMP HEIGHT ADJUST	MECHANICAL
2836535-2	C	FINE CRIMP HEIGHT ADJUST	PNEUMATIC
7-2836535-1	C	MECHANICAL AND CRIMP TOOLING KIT	MECHANICAL
7-2836535-2	C	PNEUMATIC AND CRIMP TOOLING KIT	PNEUMATIC
7-2836535-7	A	CRIMP TOOLING KIT	-

ATLANTIC VERSION TERMINATOR INTERFACE ADAPTER

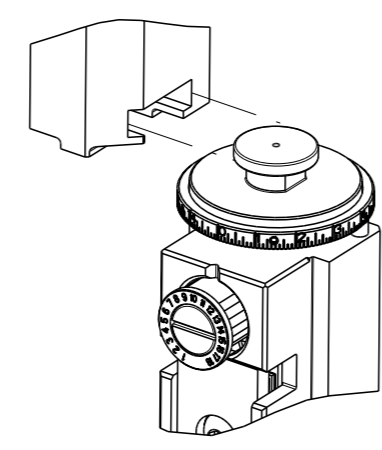

APPLICATOR DATA		
CRIMP	SIZE	TYPE
WIRE	1.40 mm [.055]	F
INSUL	1.70 mm [.067]	O

APPLICATOR INSTRUCTIONS
408-35042

TERMINAL DATA: MOLEX TERMINAL MOLEX CRIMP SPECIFICATION			
TERMINAL NAME: SL CRIMP TERMINAL, MALE 22-24AWG			
WIRE STRIP LENGTH	INSULATION DIAMETER RANGE		
3.17-3.56 mm [.125-.140 IN]	∅ 5		
TERMINAL APPLICATION SPECIFICATION	ATS-639027800 Rev A	-	-
TERMINALS APPLIED			
TE TERMINAL	MOLEX TERMINAL	TE TERMINAL	MOLEX TERMINAL
1572062-1	16-02-0081	1572062-6	70021-0019
1572062-2	16-02-0107	1572062-7	70021-0021
1572062-3	16-02-0116	1572062-8	70021-0023
1572062-4	16-02-0093	1572062-9	70021-0081
1572062-5	40-08-0874		

TERMINAL DATA: MOLEX TERMINAL MOLEX CRIMP SPECIFICATION			
TERMINAL NAME: SL CRIMP TERMINAL, MALE 22-24AWG			
WIRE STRIP LENGTH	INSULATION DIAMETER RANGE		
3.00-3.50 mm [.118-.138 IN]	∅ 5		
TERMINAL APPLICATION SPECIFICATION	ATS-639027800 Rev A	-	-
TERMINALS APPLIED			
TE TERMINAL	MOLEX TERMINAL	TE TERMINAL	MOLEX TERMINAL
1-1572062-0	50088-8000	1-1572062-3	50088-8060
1-1572062-1	50088-8014	1-1572062-4	50088-8099
1-1572062-2	50088-8028		

WIRE SIZE	CRIMP HEIGHT mm [INCH]	CRIMP HEIGHT REFERENCE SETTING
22 AWG	0.87+/-0.025 [.034+/- .001]	6.8
24 AWG	0.78+/-0.035 [.031+/- .001]	7.7

WIRE SIZE	CRIMP HEIGHT mm [INCH]	CRIMP HEIGHT REFERENCE SETTING
22 AWG	0.87+/-0.025 [.034+/- .001]	6.8
24 AWG	0.78+/-0.025 [.031+/- .001]	7.7

- 1 RECOMMENDED SPARE PARTS
- 2 REFER TO SUPPLIED INSTRUCTION SHEET FOR CLEANING, LUBRICATION AND STORAGE OF APPLICATOR.
- 3 APPLY PART NUMBER 2-23419-6 LOCTITE TO THREADS OF ITEM 242.
- 4 CRIMP HEIGHT REFERENCE SETTING WAS THE SETTING USED WHEN THE APPLICATOR WAS QUALIFIED AT THE FACTORY. ADJUSTMENT MAY BE NECESSARY WHEN RUNNING APPLICATOR IN THE FIELD.
- 5 TO ACHIEVE OPTIMUM IPC-A620 CLASS 2 INSULATION CRIMP, USE DIAMETER RANGE 1.25-1.45mm. THE OVERALL INSULATION DIAMETER FOR TERINAL SERIES 70021 IS 1.40-1.63mm & 1.0-1.60mm FOR TERMINAL SERIES 50088.
- 6. UNLESS SPECIFIED OTHERWISE TORQUE VALUES SHALL BE USED PER DOCUMENT, 101-35000.

***WARNING**
ON INSTALLATION, SET WIRE DISC TO CRIMP HEIGHT REFERENCE SETTING FOR LARGEST WIRE SIZE. CRIMP HEIGHT REFERENCE SETTINGS GREATER THAN THE VALUE SHOWN MAY CAUSE DAMAGE TO THE CRIMP TOOLING. REFER TO THE INSTRUCTION SHEET FOR PROPER SETUP AND ADJUSTMENTS.

LOC	DIST	REVISIONS					
		#	LY#	DESCRIPTION	DATE	OWN	APVD
A	66	1		DEVELOPMENT	26APR2010	YY	KZ
		A		RELEASED	12DEC2016	YY	CT
		B		ECR-19-011292	17JUL2019	TB	TE
		C		ECR-20-017405	08DEC2020	JWC	GB

-	1	1	1	1	2280441-1	INSERT, SHEAR	282	
-	1	-	1	-	2119641-1	FEED CAM, AIR FEED	248	
-	1	1	1	1	2119082-5	CAM, SNAIL, INSULATION ADJUSTMENT	244	
-	1	1	1	1	2079764-1	WASHER, WAVE SPRING, CREST-TO-CREST	243	
3	-	1	1	1	2119083-1	RETAINER, INSULATION DIAL	242	
-	2	2	2	2	7-18023-7	SCR, SKT HD CAP M3 X 4.0	241	
-	-	1	-	1	2119580-1	MECHANICAL FEED ASSEMBLY	239	
-	1	-	1	-	2844940-1	AIR FEED MODULE	238	
-	1	1	1	1	356885-4	STOP, SHEAR	237	
-	REF	REF	REF	REF	994970-2	COUNTER, MAGNETIC	164	
-	1	1	1	1	2844908-1	SCREW, LOCKING	99	
-	1	1	1	1	2844907-1	POST, LOCKING	98	
-	1	1	1	1	455888-6	SPACER, CRIMPER	82	
-	1	1	1	1	1803607-3	DOCUMENTATION PACKAGE	71	
-	1	1	1	1	2119740-1	TAG, IDENTIFICATION	67	
-	2	2	2	2	2168078-1	SCREW, DRIVE, RH, RoHS, 2 x .188	66	
-	1	1	1	1	2168083-2	SCR, SKT HD CAP, RoHS, M4 X 8.0	60	
-	1	1	1	1	5-18022-5	SCR, HEX HD CAP, M4 X 6.0	59	
-	1	1	1	1	1338685-1	PAWL, FEED	56	
-	4	4	4	4	2168083-3	SCR, SKT HD CAP, RoHS, M4 X 12.0	54	
-	2	2	2	2	1-2168083-2	SCR, SKT HD CAP, RoHS, M4 X 25	53	
-	1	2	1	2	18023-9	SCR, SKT HD CAP M4 X 6.0	49	
-	-	1	-	1	2119652-1	FEED CAM, PRE FEED	48	
-	-	1	-	1	2119653-1	FEED CAM, POST FEED	47	
-	1	1	1	1	1803583-9	APPLICATOR BASIC ASSEMBLY, SF	46	
-	1	1	1	1	1803515-1	RAM ASSEMBLY, SF ATLANTIC	44	
-	1	1	1	1	1803602-1	SCR, BHSC, RoHS (M8 X 25)	41	
-	2	2	2	2	2079383-5	SCR, BHSC, RoHS (M4 X 20)	33	
-	2	2	2	2	2-2844962-3	SPACER, CYLINDRICAL, STRIP GUIDE	30	
-	1	1	1	1	2844992-1	ASSEMBLY, STRIP GUIDE	29	
-	1	1	1	1	455888-3	SPACER, CRIMPER	28	
-	1	1	1	1	1320928-2	STRIP GUIDE	24	
-	1	1	1	1	2168083-2	SCR, SKT HD CAP, RoHS, M4 X 8.0	21	
-	2	2	2	2	1-18028-2	WASHER, FLAT, REG M4	20	
-	1	1	1	1	2119533-1	STRIPPER, SIDE FEED	19	
-	1	1	1	1	2-690518-4	HOLD DOWN, TERMINAL	18	
-	1	1	1	1	690463-1	FLOATING SHEAR, REAR	17	
-	2	2	2	2	1-2168083-1	SCR, SKT HD CAP, RoHS, M3 X 6	16	
-	1	1	1	1	690464-1	SHEAR PLATE, REAR	15	
-	1	1	1	1	2119862-1	SHEAR HOLDER, REAR	14	
1	-	1	1	1	2119806-1	INSERT, SHEAR	13	
-	2	2	2	2	3-22280-3	SPRING, COMPRESSION	12	
-	1	1	1	1	1-356885-4	STOP, SHEAR	11	
1	-	1	1	1	2119805-1	SHEAR HOLDER, FRONT	10	
1	-	1	1	1	1803095-1	FLOATING SHEAR, FRONT	9	
1	1	2	2	1	1	8-1803057-9	ANVIL, COMBINATION	8
-	1	1	1	1	7-240641-8	SPACER	7	
-	1	1	1	1	690468-1	DEPRESSOR SHEAR, REAR	6	
-	1	1	1	1	2119757-8	DEPRESSOR, SHEAR	5	
-	1	1	1	1	5-238011-6	BLOCK, CRIMPER SPACER	4	
1	1	2	2	1	1	2-1803019-0	CRIMPER, INSULATION O	3
-	1	1	1	1	455888-5	SPACER, CRIMPER	2	
1	1	2	2	1	1	1-456402-0	CRIMPER, WIRE PREMIUM	1

ATLANTIC VERSION
Shown on sheets 1 of 4 & 2 of 4
(Pacific version shown on sheets 3 of 4 & 4 of 4)

DIMENSIONS:		TOLERANCES UNLESS OTHERWISE SPECIFIED:		MATERIAL:	
mm	0 PLC ±	1 PLC ±	2 PLC ±	3 PLC ±	4 PLC ±
	ANGLES	FINISH			

OWN	Y. YIN	07NOV2016		TE Connectivity	Harrisburg, PA 17105-3608
CHK	G. BAILEY	07NOV2016		NAME	Ocean Side Feed Applicator
APVD	K. ZANG	07NOV2016	PRODUCT SPEC	SIZE	CAGE CODE
			APPLICATION SPEC	00779	2836535
			WEIGHT	SCALE	1:2
				SHEET	1 of 4
				REV	C

LOC	DIST	REVISIONS			
A	66	REV	DATE	OWN	APVD
		-	SEE SHEET 1	-	-

FEED TYPE MECHANICAL

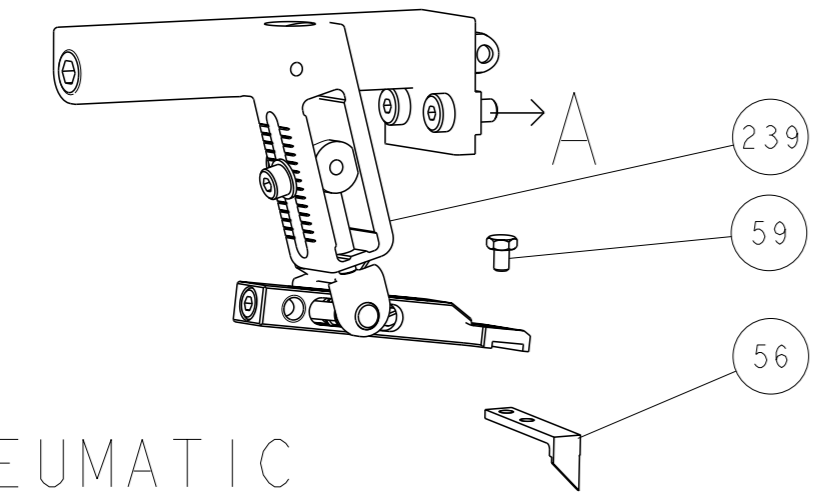

PNEUMATIC

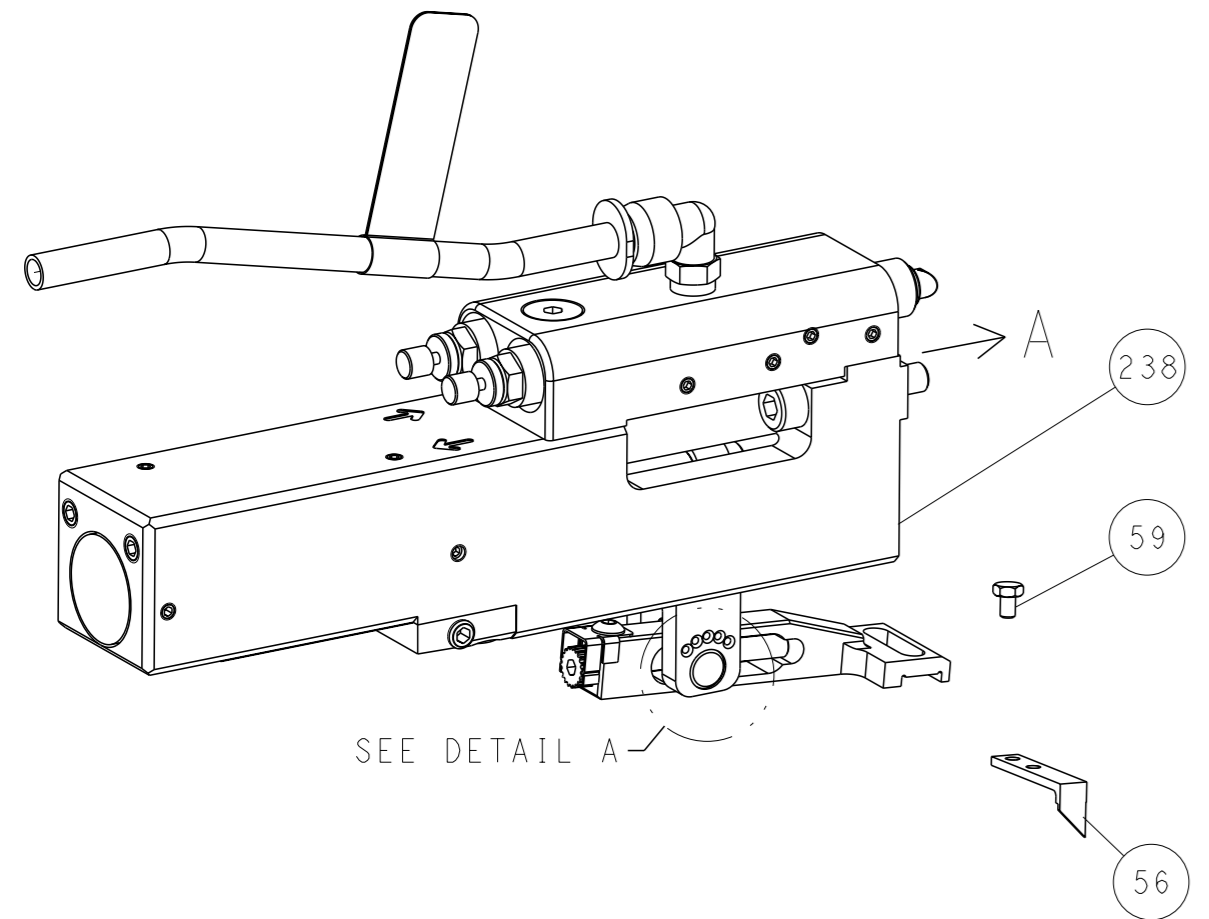

FEED SPRING SETTING POSITION (SHOWN FROM REAR SIDE)

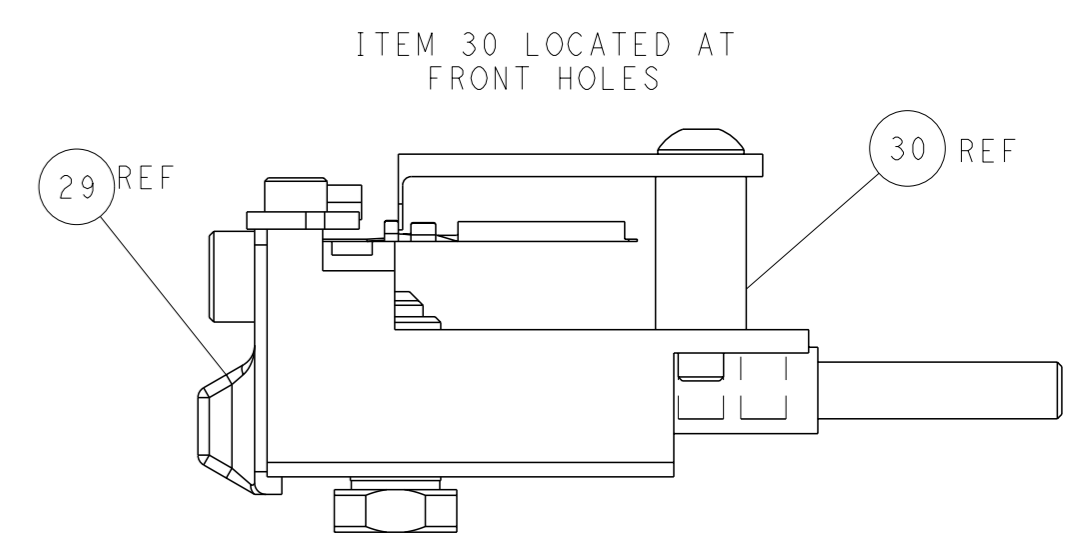
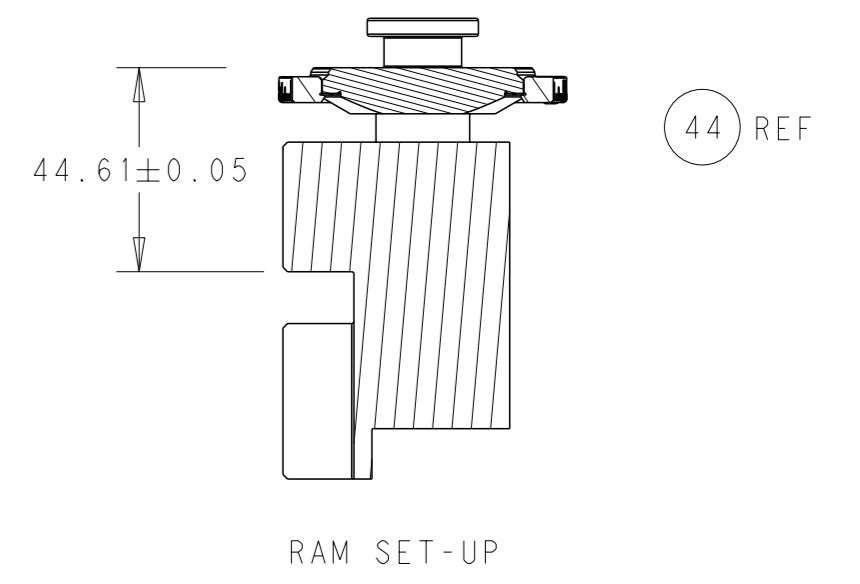
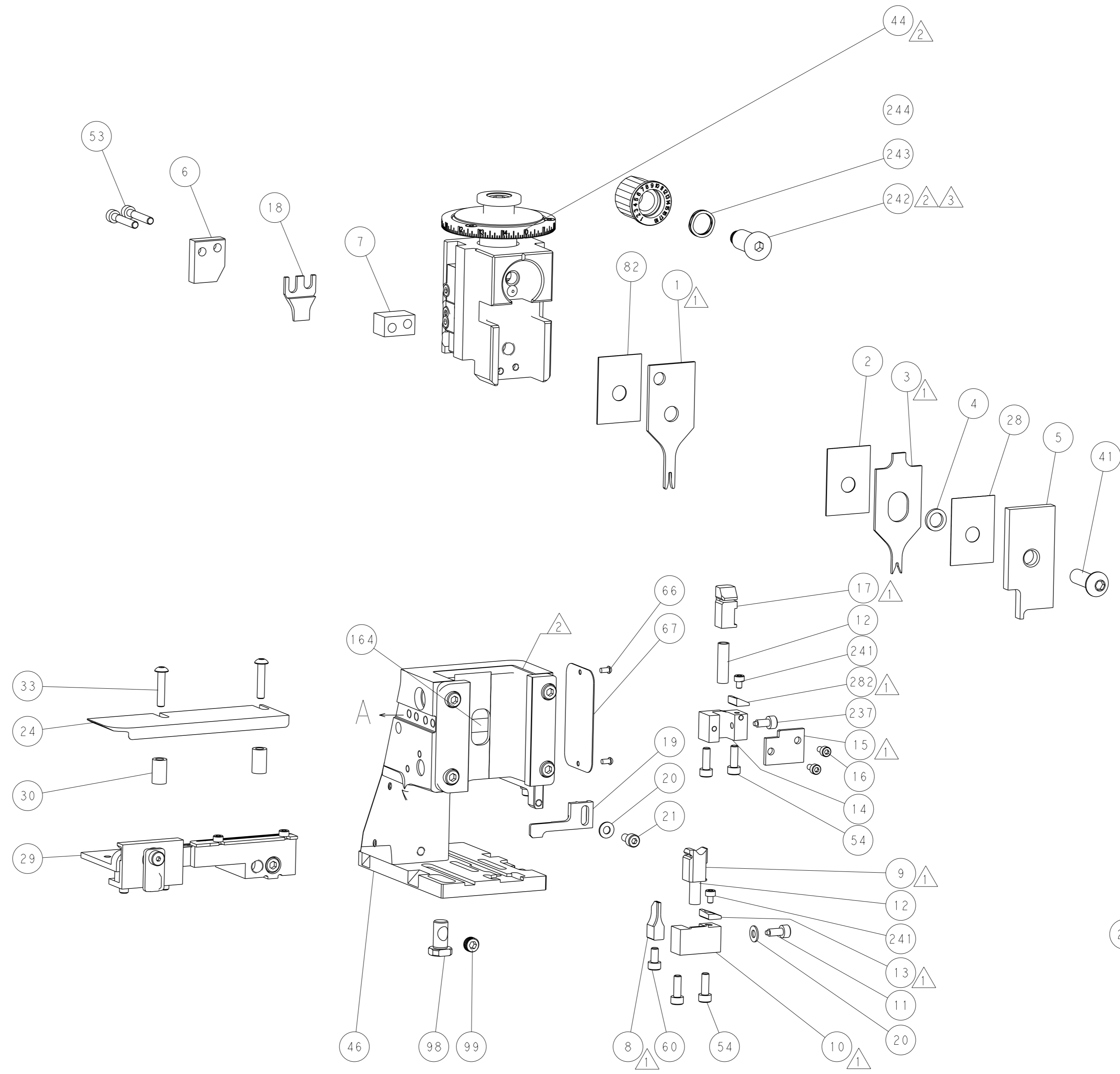

CAM POSITIONS

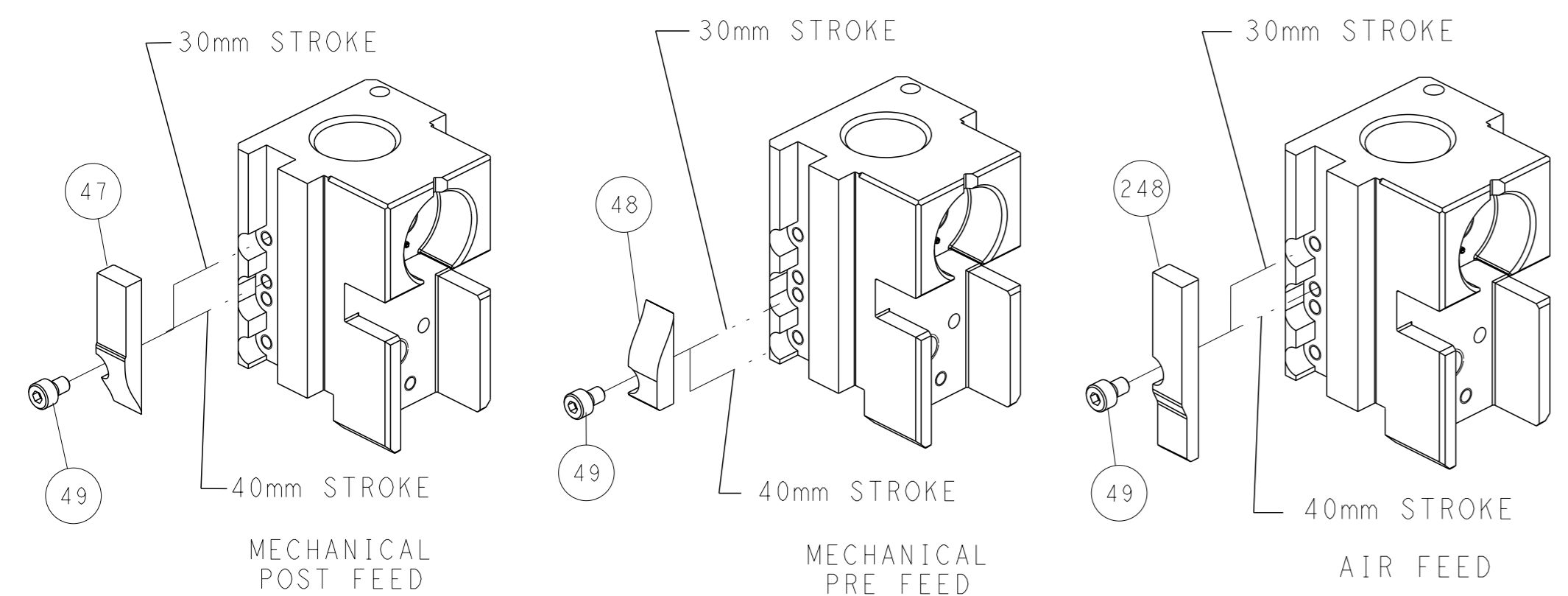

ATLANTIC VERSION
 Shown on sheets 1 of 4 & 2 of 4
 (Pacific version shown on sheets 3 of 4 & 4 of 4)

DIMENSIONS: mm 		TOLERANCES UNLESS OTHERWISE SPECIFIED: 0 PLC ± 1 PLC ± 2 PLC ± 3 PLC ± 4 PLC ± ANGLES ±		OWN: Y. YIN 07NOV2016 CHK: G. BAILEY 07NOV2016 APVD: K. ZANG 07NOV2016 PRODUCT SPEC APPLICATION SPEC WEIGHT: - MATERIAL: -		NAME: Ocean Side Feed Applicator SIZE: A1 CAGE CODE: 00779 DRAWING NO: 2836535 SCALE: 1:2 SHEET: 2 of 4 REV: C	
--------------------	--	-----------------------------------------------------------------------------------------------------------	--	----------------------------------------------------------------------------------------------------------------------------------------------	--	----------------------------------------------------------------------------------------------------------------------------------	--

PART NUMBER	REVISION	DESCRIPTION	FEED TYPE
2-2836535-1	C	FINE CRIMP HEIGHT ADJUST	MECHANICAL
2-2836535-2	C	FINE CRIMP HEIGHT ADJUST	PNEUMATIC
7-2836535-7	A	CRIMP TOOLING KIT	-

PACIFIC VERSION TERMINATOR INTERFACE ADAPTER

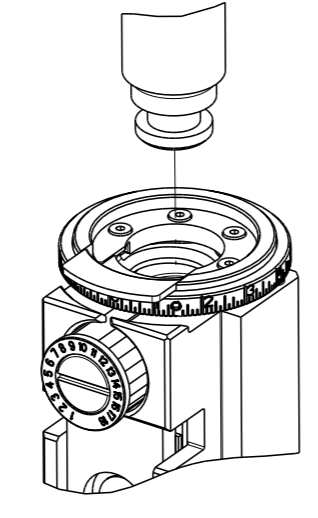

APPLICATOR DATA		
CRIMP	SIZE	TYPE
WIRE	1.40 mm (.055)	F
INSUL	1.70 mm (.067)	O
APPLICATOR INSTRUCTIONS 408-35042		

TERMINAL DATA: MOLEX TERMINAL MOLEX CRIMP SPECIFICATION			
TERMINAL NAME: SL CRIMP TERMINAL, MALE 22-24AWG			
WIRE STRIP LENGTH	INSULATION DIAMETER RANGE		
3.17-3.56 mm (.125-.140 IN)	∅ 5		
TERMINAL APPLICATION SPECIFICATION ATS-639027800 Rev A			
TERMINALS APPLIED			
TE TERMINAL	MOLEX TERMINAL	TE TERMINAL	MOLEX TERMINAL
1572062-1	16-02-0081	1572062-6	70021-0019
1572062-2	16-02-0107	1572062-7	70021-0021
1572062-3	16-02-0116	1572062-8	70021-0023
1572062-4	16-02-0093	1572062-9	70021-0081
1572062-5	40-08-0874		

TERMINAL DATA: MOLEX TERMINAL MOLEX CRIMP SPECIFICATION			
TERMINAL NAME: SL CRIMP TERMINAL, MALE 22-24AWG			
WIRE STRIP LENGTH	INSULATION DIAMETER RANGE		
3.00-3.50 mm (.118-.138 IN)	∅ 5		
TERMINAL APPLICATION SPECIFICATION ATS-639027800 Rev A			
TERMINALS APPLIED			
TE TERMINAL	MOLEX TERMINAL	TE TERMINAL	MOLEX TERMINAL
1-1572062-0	50088-8000	1-1572062-3	50088-8060
1-1572062-1	50088-8014	1-1572062-4	50088-8099
1-1572062-2	50088-8028		

WIRE SIZE	CRIMP HEIGHT mm [INCH]	CRIMP HEIGHT REFERENCE SETTING
22 AWG	0.87+/-0.025 [.034+/-0.001]	6.8
24 AWG	0.78+/-0.035 [.031+/-0.001]	7.7

WIRE SIZE	CRIMP HEIGHT mm [INCH]	CRIMP HEIGHT REFERENCE SETTING
22 AWG	0.87+/-0.025 [.034+/-0.001]	6.8
24 AWG	0.78+/-0.025 [.031+/-0.001]	7.7

- RECOMMENDED SPARE PARTS
- REFER TO SUPPLIED INSTRUCTION SHEET FOR CLEANING, LUBRICATION AND STORAGE OF APPLICATOR.
- APPLY PART NUMBER 2-23419-6 LOCTITE TO THREADS OF ITEM 242.
- CRIMP HEIGHT REFERENCE SETTING WAS THE SETTING USED WHEN THE APPLICATOR WAS QUALIFIED AT THE FACTORY. ADJUSTMENT MAY BE NECESSARY WHEN RUNNING APPLICATOR IN THE FIELD.
- TO ACHIEVE OPTIMUM IPC-A620 CLASS 2 INSULATION CRIMP, USE DIAMETER RANGE 1.25-1.45mm. THE OVERALL INSULATION DIAMETER FOR TERINAL SERIES 70021 IS 1.40-1.63mm & 1.0-1.60mm FOR TERMINAL SERIES 50088.
- UNLESS SPECIFIED OTHERWISE TORQUE VALUES SHALL BE USED PER DOCUMENT, 101-35000.

***WARNING**
ON INSTALLATION, SET WIRE DISC TO CRIMP HEIGHT REFERENCE SETTING FOR LARGEST WIRE SIZE. CRIMP HEIGHT REFERENCE SETTINGS GREATER THAN THE VALUE SHOWN MAY CAUSE DAMAGE TO THE CRIMP TOOLING. REFER TO THE INSTRUCTION SHEET FOR PROPER SETUP AND ADJUSTMENTS.

PACIFIC VERSION
Shown on sheets 3 of 4 & 4 of 4
(Atlantic version shown on sheets 1 of 4 & 2 of 4)

LOC	DIST	REV	DATE	BY	APPV
A	66				

REV	QTY	DESCRIPTION	DATE	OWN	APPV
-	1	1	2280441-1	INSERT, SHEAR	282
-	1	1	2119082-5	CAM, SNAIL, INSULATION ADJUSTMENT	244
-	1	1	2079764-1	WASHER, WAVE SPRING, CREST-TO-CREST	243
-	1	1	2119083-1	RETAINER, INSULATION DIAL	242
-	2	2	7-18023-7	SCR, SKT HD CAP M3 X 4.0	241
-	-	1	2119580-1	MECHANICAL FEED ASSEMBLY	239
-	1	-	2844940-1	AIR FEED MODULE	238
-	1	1	356885-4	STOP, SHEAR	237
-	REF	REF	994970-2	COUNTER, MAGNETIC	164
-	1	-	2119641-2	FEED CAM, AIR FEED	151
-	1	1	2168083-8	SCR, SKT HD CAP, RoHS, M4 X 16	144
-	4	4	2168083-9	SCR, SKT HD CAP, RoHS, M4 X 20	143
-	-	1	2119653-2	FEED CAM, POST FEED	142
-	1	1	1-1803583-0	APPLICATOR BASIC ASSEMBLY, SF	141
-	1	1	1803516-1	RAM ASSEMBLY, SF PACIFIC	140
-	1	1	2844908-1	SCREW, LOCKING	99
-	1	1	2844907-1	POST, LOCKING	98
-	1	1	455888-6	SPACER, CRIMPER	82
-	1	1	1803607-3	DOCUMENTATION PACKAGE	71
-	1	1	2119740-1	TAG, IDENTIFICATION	67
-	2	2	2168078-1	SCREW, DRIVE, RH, RoHS, 2 x .188	66
-	1	1	5-18022-5	SCR, HEX HD CAP, M4 X 6.0	59
-	1	1	1338685-1	PAWL, FEED	56
-	2	2	1-2168083-2	SCR, SKT HD CAP, RoHS, M4 X 25	53
-	1	2	18023-9	SCR, SKT HD CAP M4 X 6.0	49
-	-	1	2119652-1	FEED CAM, PRE FEED	48
-	1	1	1803602-1	SCR, BHSC, RoHS (M8 X 25)	41
-	2	2	2079383-5	SCR, BHSC, RoHS (M4 X 20)	33
-	2	2	2-2844962-3	SPACER, CYLINDRICAL, STRIP GUIDE	30
-	1	1	2844992-1	ASSEMBLY, STRIP GUIDE	29
-	1	1	455888-3	SPACER, CRIMPER	28
-	1	1	1320928-2	STRIP GUIDE	24
-	1	1	2168083-2	SCR, SKT HD CAP, RoHS, M4 X 8.0	21
-	2	2	1-18028-2	WASHER, FLAT, REG M4	20
-	1	1	2119533-1	STRIPPER, SIDE FEED	19
-	1	1	2-690518-4	HOLD DOWN, TERMINAL	18
-	1	1	690463-1	FLOATING SHEAR, REAR	17
-	2	2	1-2168083-1	SCR, SKT HD CAP, RoHS, M3 X 6	16
-	1	1	690464-1	SHEAR PLATE, REAR	15
-	1	1	2119862-1	SHEAR HOLDER, REAR	14
-	1	1	2119806-1	INSERT, SHEAR	13
-	2	2	3-22280-3	SPRING, COMPRESSION	12
-	1	1	1-356885-4	STOP, SHEAR	11
-	1	1	2119805-1	SHEAR HOLDER, FRONT	10
-	1	1	1803095-1	FLOATING SHEAR, FRONT	9
1	1	1	8-1803057-9	ANVIL, COMBINATION	8
-	1	1	7-240641-8	SPACER	7
-	1	1	690468-1	DEPRESSOR SHEAR, REAR	6
-	1	1	2119757-8	DEPRESSOR, SHEAR	5
-	1	1	5-238011-6	BLOCK, CRIMPER SPACER	4
1	1	1	2-1803019-0	CRIMPER, INSULATION O	3
-	1	1	455888-5	SPACER, CRIMPER	2
1	1	1	1-456402-0	CRIMPER, WIRE PREMIUM	1

DIMENSIONS:		TOLERANCES UNLESS OTHERWISE SPECIFIED:		MATERIAL:	
mm	0 PLC ±	1 PLC ±	2 PLC ±	3 PLC ±	4 PLC ±
	ANGLES	FINISH			

OWN	Y. YIN	07NOV2016
CHK	G. BAILEY	07NOV2016
APPV	K. ZANG	07NOV2016
NAME	Ocean Side Feed Applicator	
SIZE	CAGE CODE	DRAWING NO
A1	00779	2836535
Customer Accessible Production Drawing		
SCALE	1:2	SHEET 3 of 4

LOC		DIST		REVISIONS			
A	66	P	LYR	DESCRIPTION	DATE	OWN	APVD
		-		SEE SHEET 1			

FEED TYPE MECHANICAL

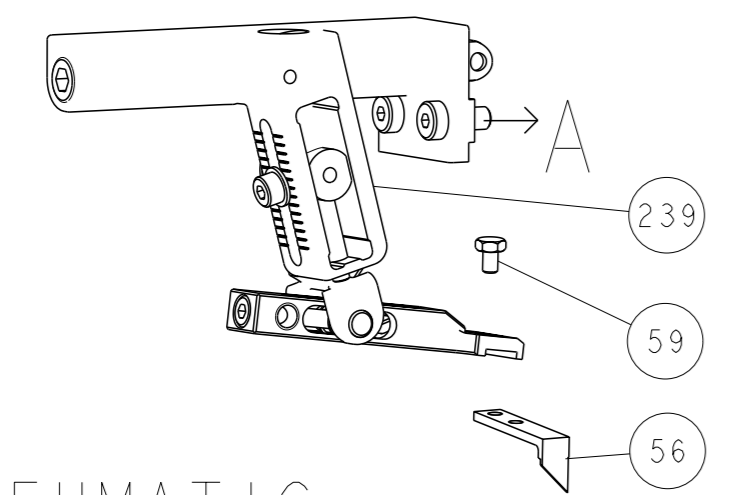

PNEUMATIC

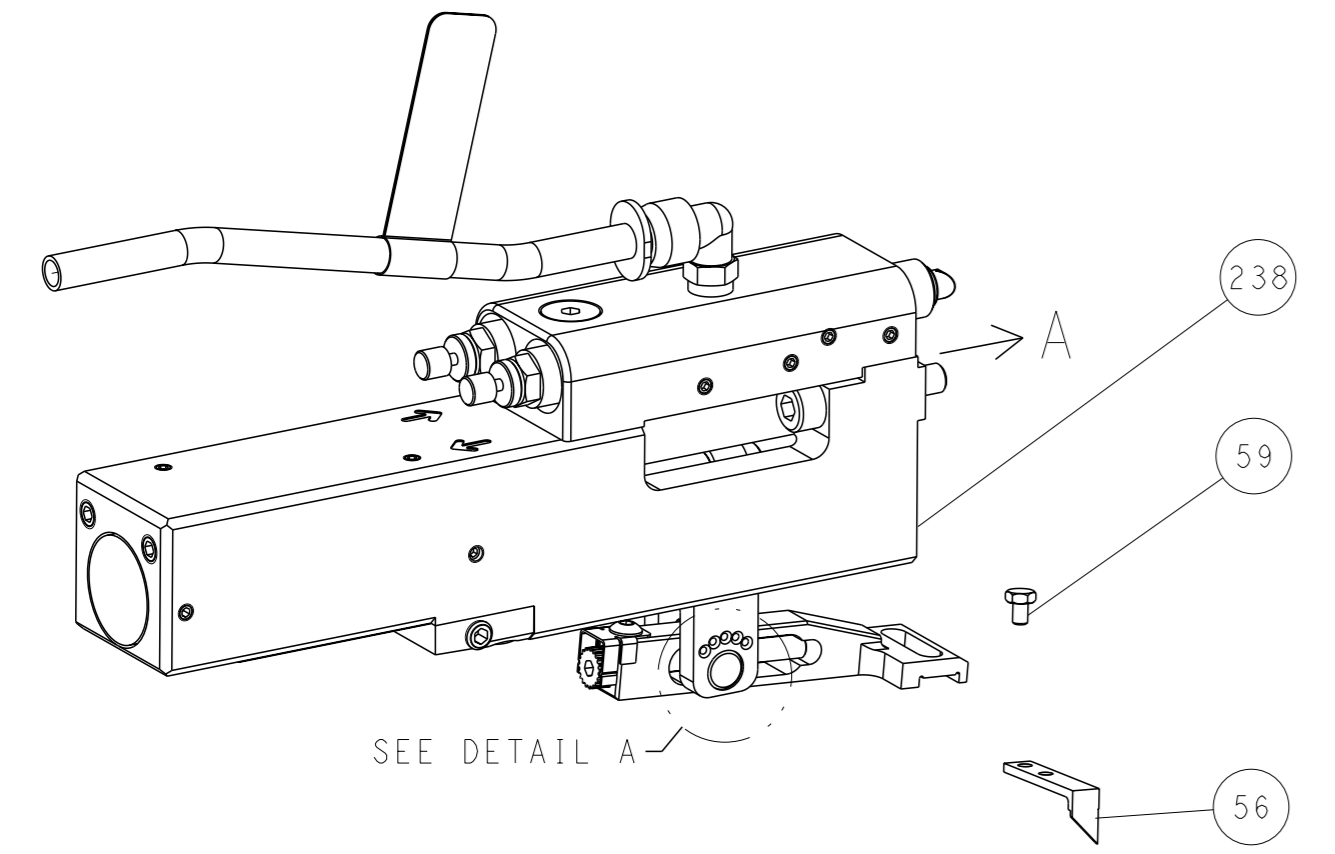

FEED SPRING SETTING POSITION
(SHOWN FROM REAR SIDE)

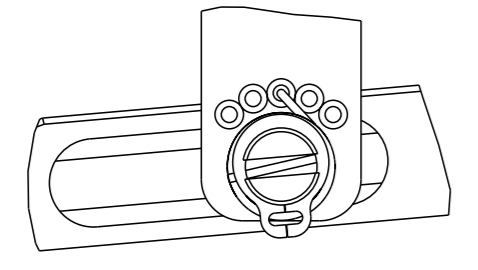

DETAIL A

CAM POSITIONS

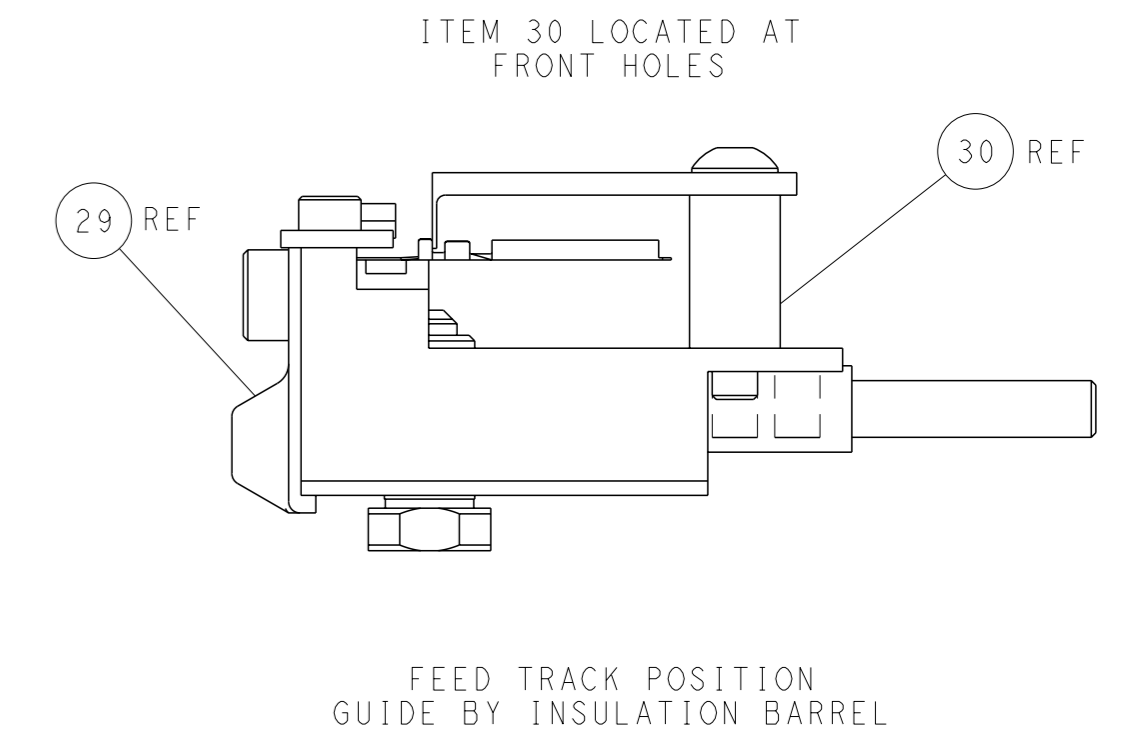
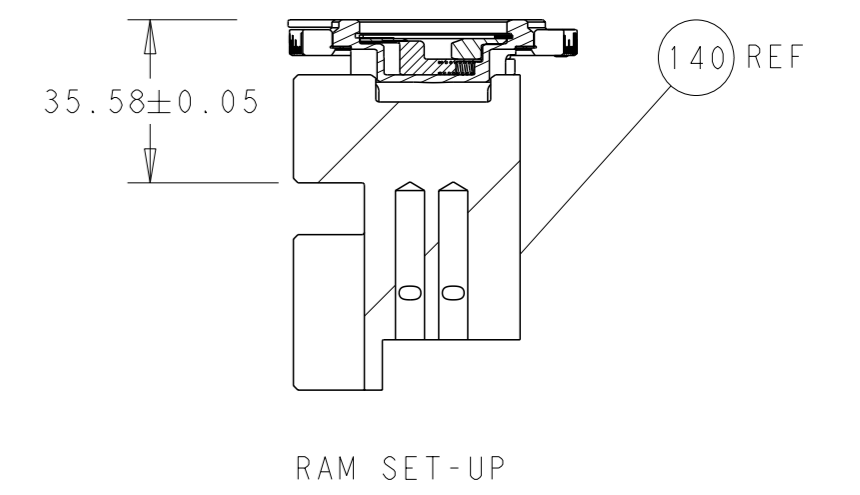
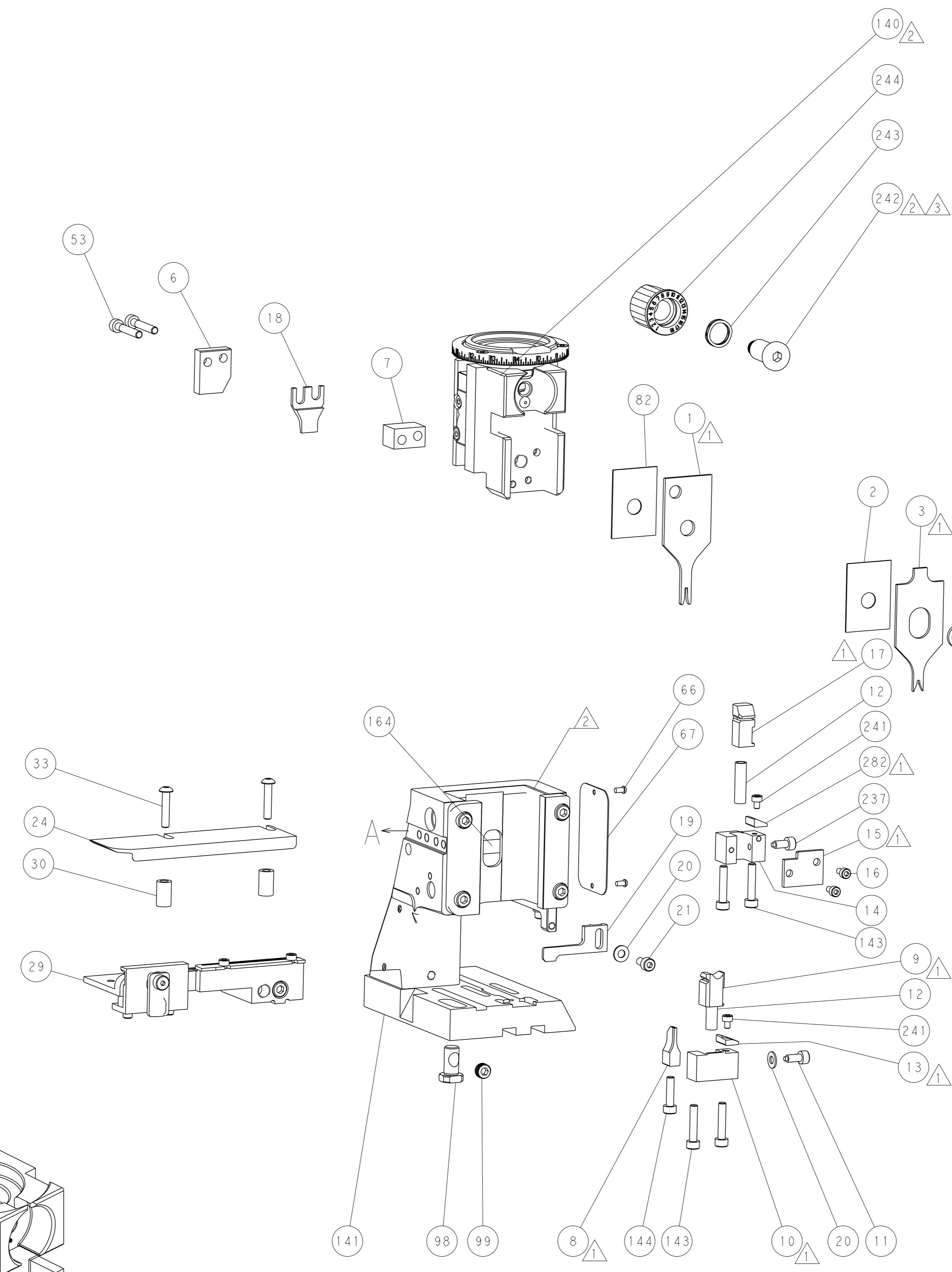
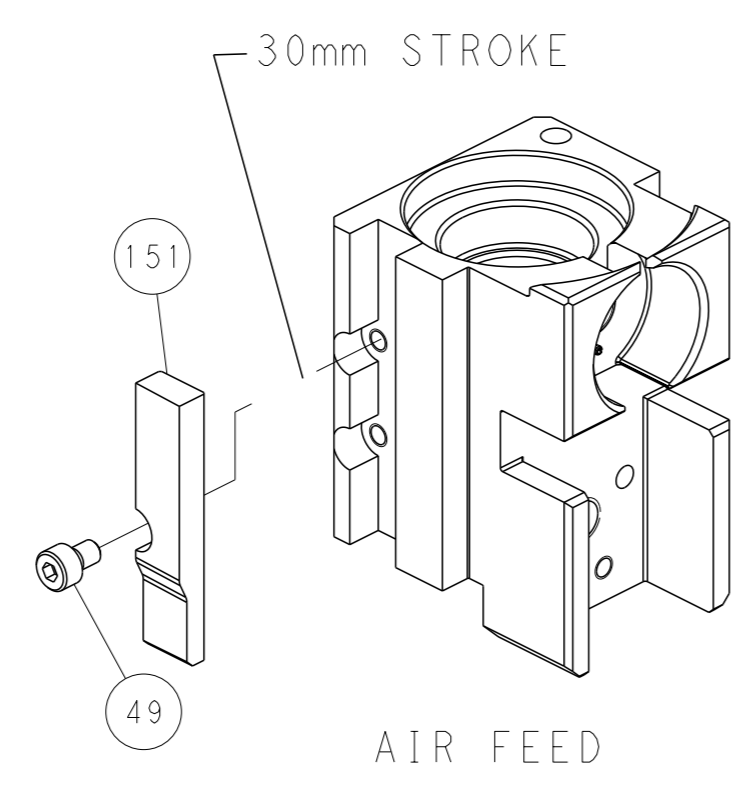
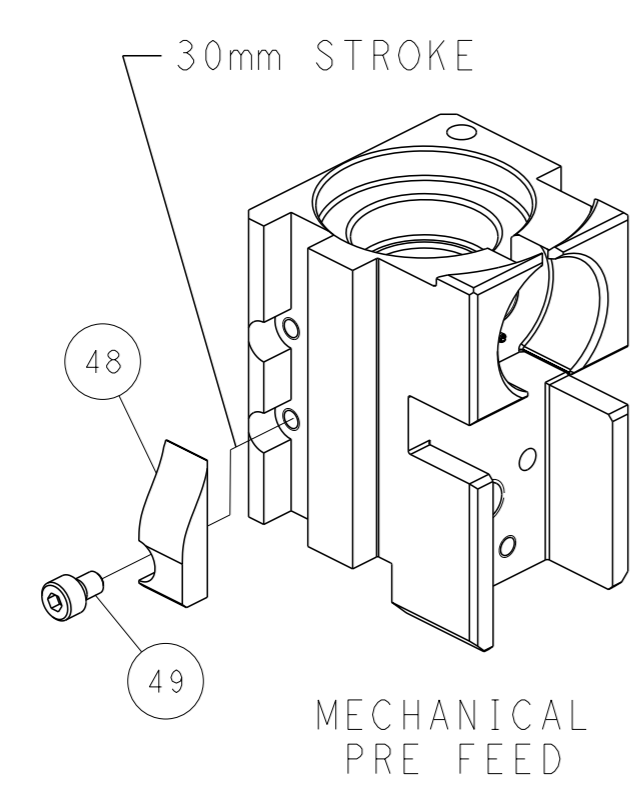
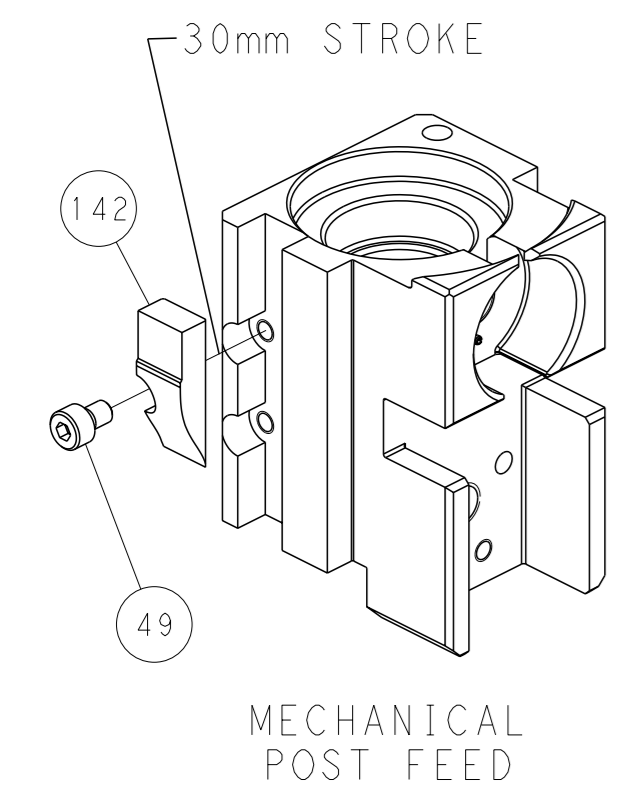

PACIFIC VERSION
 Shown on sheets 3 of 4 & 4 of 4
 (Atlantic version shown on sheets 1 of 4 & 2 of 4)

DIMENSIONS: mm 		TOLERANCES UNLESS OTHERWISE SPECIFIED: 0 PLC ± 1 PLC ± 2 PLC ± 3 PLC ± 4 PLC ± ANGLES FINISH ±		OWN: Y. YIN 07NOV2016 CHK: G. BAILEY 07NOV2016 APVD: K. ZANG 07NOV2016 PRODUCT SPEC APPLICATION SPEC WEIGHT: - Customer Accessible Production Drawing		NAME: Ocean Side Feed Applicator SIZE: A1 CAGE CODE: 00779 DRAWING NO: C=2836535 SCALE: 1:2 SHEET: 4 of 4 REV: C	
MATERIAL: -				RESTRICTED TO: -		SHEETS 1 & 2 ARE NOT REQUIRED FOR PACIFIC VERSION	