

PART NUMBER	REV	DESCRIPTION
2359762-1	C	HV DIE SET
7-2359762-7	C	CRIMP TOOLING KIT
9-2359762-1	C	DIE SET WITH DIE HOLDER

REVISIONS					
P	LTN	DESCRIPTION	DATE	DWN	APVD
A2		REVISED PER ECR-21-117516	18OCT2021	GK	YY
B		ECR-21-122544	30NOV2021	KH	YY
C		ECR-22-133949	29MAR2022	LS	TE
C1		REVISED PER ECR-23-187199	15SEP2023	GK	KH

TERMINAL NAME	8MM HV, BODY, PLATED		
TE TERMINAL PART NUMBER(S)	2-2141211-2 3-2141211-2		
APPLICATION SPECIFICATION	114-94083		
REFERENCE DRAWING	-		
USED ON	2305470-1	2326378-1	
INSTRUCTION SHEET	408-35334		

CABLE SUPPLIER/SPECIFICATION	CABLE SIZE	CRIMP HEIGHT	CRIMP HEIGHT REFERENCE SETTING
COROPLAST FHRL2GCB2G	35MM2	8,0 ±0.15	D2
COROPLAST FHRL2GCB2G	50MM2	8.8 ±0.15	C5

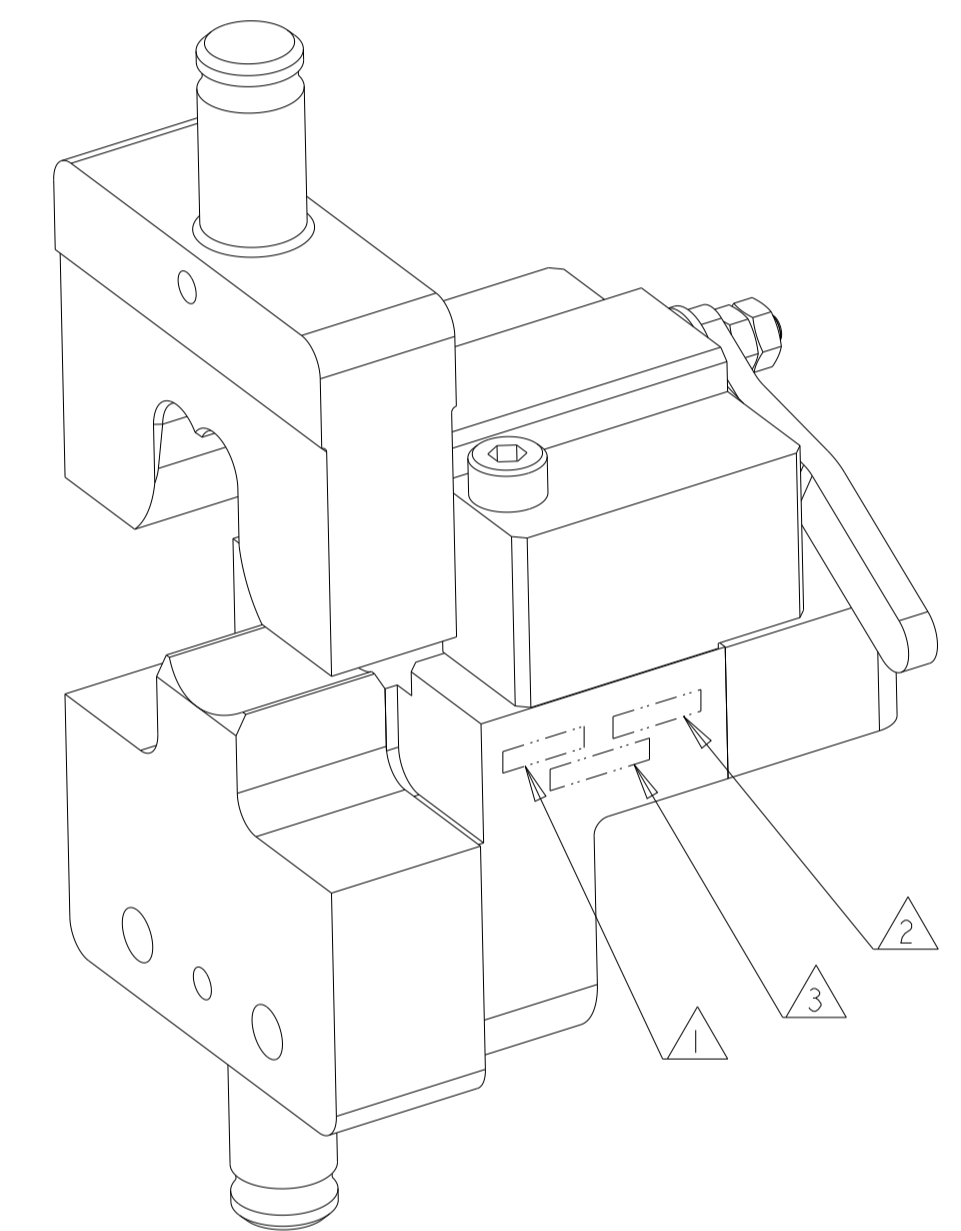
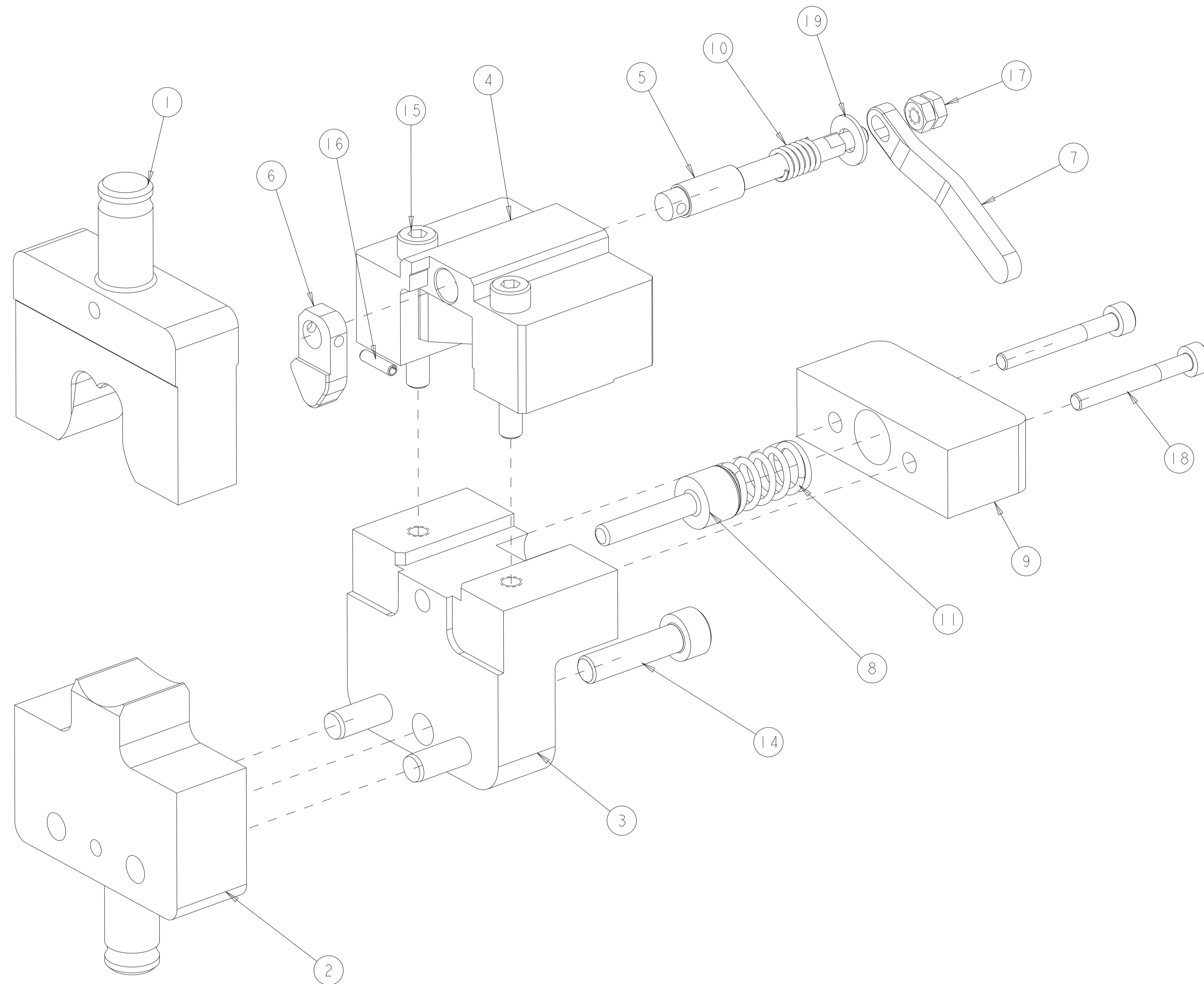

1	-	-	-	2305470-1	HV DIE HOLDER WITH FINE ADJUST	100
1	-	1	-	18028-2	WASHER, FLAT, REG M4	19
2	-	2	-	7-18023-6	SCR, SKT HD CAP M3 X 25.0	18
2	-	2	-	519021-7	NUT, HEX -	17
1	-	1	-	519059-4	SPRING-TYPE STRAIGHT PIN -	16
2	-	2	-	1-18023-5	SCR, SKT HD CAP M4 X 25.0	15
1	-	1	-	2-18023-1	SCR, SKT HD CAP M5 X 20.0	14
1	-	1	-	6-22282-3	SPRING, COMPRESSION	11
1	-	1	-	8-653861-7	SPRING, COMPRESSION	10
1	-	1	-	2305469-1	RETAINER, SPRING	9
1	-	1	-	2305821-4	PIN, EXTRUSION -	8
1	-	1	-	2386384-1	LEVER -	7
1	-	1	-	2401532-1	WIRE STOP -	6
1	-	1	-	2386383-1	SHAFT -	5
1	-	1	-	2386446-2	HOLD DOWN -	4
1	-	1	-	2305468-2	LOCATOR, HV TERMINAL	3
1	1	1	-	2386452-1	ANVIL HVM F	2
1	1	1	-	2386453-1	CRIMPER HVM F	1
-91	-77	-1	U/M	PART NO	DESCRIPTION	ITEM NO

- △1 APPLY "DIE SET PN" PER TEC-115-67-2 IN APPROXIMATE AREA SHOWN.
- △2 IDENTIFY PART NUMBER AND REVISION LETTER PER TEC-115-67-2 IN APPROXIMATE AREA SHOWN.
- △3 IDENTIFY SERIAL NUMBER PER TEC-115-67-2 IN APPROXIMATE AREA SHOWN.
4. TORQUE RECOMMENDATIONS PER 101-35000 UNLESS OTHERWISE SPECIFIED.

THIS DRAWING IS A CONTROLLED DOCUMENT.		DWN L. SANDHU 04FEB2021		NAME DIE SET HV 8MM-90 T 35-50MM2
DIMENSIONS: mm		CHK L. SANDHU 04FEB2021		PRODUCT SPEC
TOLERANCES UNLESS OTHERWISE SPECIFIED:		APVD M. PAJUELO 04FEB2021	APPLICATION SPEC	SIZE CAGE CODE DRAWING NO
0 PLC ±		PRODUCT SPEC	RESTRICTED TO	SCALE 2:1 SHEET 1 OF 1 REV C1
1 PLC ±		APPLICATION SPEC	WEIGHT	CUSTOMER ACCESSIBLE PRODUCTION DRAWING
2 PLC ±		SIZE CAGE CODE DRAWING NO	RESTRICTED TO	
3 PLC ±		RESTRICTED TO		
4 PLC ±		RESTRICTED TO		
ANGLES ±		RESTRICTED TO		
FINISH ±		RESTRICTED TO		
MATERIAL		RESTRICTED TO		