

PART NUMBER	REVISION	DESCRIPTION	FEED TYPE
2266002-1	E	FINE CRIMP HEIGHT ADJUST	MECHANICAL
2266002-2	E	FINE CRIMP HEIGHT ADJUST	PNEUMATIC
5-2266002-1	E	SEAL STRIPPER CRIMPER TERMINATING UNIT	MECHANICAL
5-2266002-2	E	SEAL STRIPPER CRIMPER TERMINATING UNIT	PNEUMATIC
7-2266002-1	E	MECHANICAL AND CRIMP TOOLING KIT	MECHANICAL
7-2266002-2	E	PNEUMATIC AND CRIMP TOOLING KIT	PNEUMATIC
7-2266002-7	C	CRIMP TOOLING KIT	-

ATLANTIC VERSION TERMINATOR INTERFACE ADAPTER

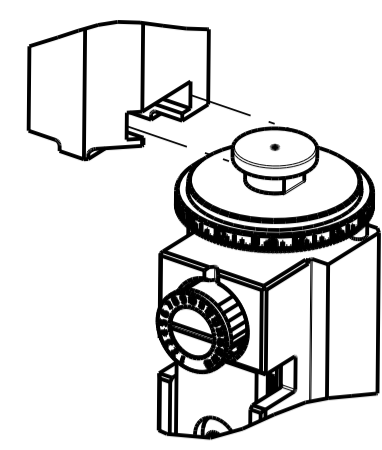

APPLICATOR DATA		
CRIMP	SIZE	TYPE
WIRE	1.57 mm [.062]	F
INSUL	3.35 mm [.132]	O

APPLICATOR INSTRUCTIONS  
408-35042

TERMINAL DATA: MOLEX(FORD) TERMINAL		MOLEX CRIMP SPECIFICATION	
TERMINAL NAME: TERMINAL			
WIRE STRIP LENGTH 4.30-5.00 mm [1.69-.197 IN]		INSULATION DIAMETER RANGE Ø1.40-1.70 mm [.055-.067 IN]	
TERMINAL APPLICATION SPECIFICATION ATS-639017400 Rev B AUST-14421-AA Rev B3			

TERMINALS APPLIED				CABLE DIAMETER
TE TERMINAL	MOLEX(FORD) TERMINAL	TE SEAL	MOLEX(FORD) SEAL	
2113354-1	34080-1106 (BUST-14421-FA)	1949248-1	97BG-10C930-SBA	Ø1.19-16.5mm
2113354-2	34080-1003 (AUST-14421-AA)		OSR SEAL	
2113354-3	34080-1206 (BUST-14421-CA)	2113614-1	E-1644-01	
		2113406-1	A-0370B	

WIRE SIZE	CRIMP HEIGHT mm [INCH]	CRIMP HEIGHT REFERENCE SETTING
0.50mm2	1.10+/-0.05 [1.043+/-0.002]	7.2
22AWG or 0.35mm2	1.00+/-0.05 [1.039+/-0.002]	8.3

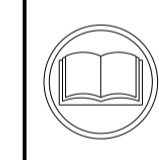

- RECOMMENDED SPARE PARTS
- REFER TO SUPPLIED INSTRUCTION SHEET FOR CLEANING, LUBRICATION AND STORAGE OF APPLICATOR.
- APPLY PART NUMBER 2-23419-6 LOCTITE TO THREADS OF ITEM 242. APPLY PART NUMBER 1-23419-5 LOCTITE TO THREADS OF ITEM 180.
- CRIMP HEIGHT REFERENCE SETTING WAS THE SETTING USED WHEN THE APPLICATOR WAS QUALIFIED AT THE FACTORY. ADJUSTMENT MAY BE NECESSARY WHEN RUNNING APPLICATOR IN THE FIELD.
- TERMINAL LUBRICANT IS RECOMMENDED.
- 6. UNLESS SPECIFIED OTHERWISE TORQUE VALUES SHALL BE USED PER DOCUMENT, 101-35000.
- APPLY TORQ-SEAL IN ALLEN SOCKET TO FILL HOLE AFTER FLAT HD HAS BEEN ADJUSTED TO CORRECT HEIGHT AT QUALIFICATION. APPLY #1-23419-5 LOC-TITE TO THREADS.

**\*WARNING**  
 ON INSTALLATION, SET WIRE DISC TO CRIMP HEIGHT REFERENCE SETTING FOR LARGEST WIRE SIZE. CRIMP HEIGHT REFERENCE SETTINGS GREATER THAN THE VALUE SHOWN MAY CAUSE DAMAGE TO THE CRIMP TOOLING. REFER TO THE INSTRUCTION SHEET FOR PROPER SETUP AND ADJUSTMENTS.

LOC	DIST	REV	DATE	BY	CHK	APPV
A	66	C	15JAN2014	XZ	TE	
		D	17SEP2020	TB	GB	
		D1	04MAR2021	LG	TE	
		E	28APR2021	FZ	RK	

REV	DATE	BY	CHK	APPV	DESCRIPTION	ITEM NO		
-	-	-	1	1	-	2-1803583-1	APPLICATOR BASIC ASSEMBLY, SF	292
-	2	2	2	2	2	22281-8	SPRING, COMPRESSION	269
-	2	2	2	2	2	2-18032-5	SCR, SET, FLT PNT, M5 X 20.0	268
-	1	1	1	1	1	980371-4	SCR, SKT HD SHLDR 5.0 DIA X 6.0	267
-	1	1	1	1	1	356835-1	LEVER, DRAG RELEASE	266
-	1	-	1	-	1	2119641-1	FEED CAM, AIR FEED	248
-	1	1	1	1	1	2119082-7	CAM, SNAIL, INSULATION ADJUSTMENT	244
-	1	1	1	1	1	2079764-1	WASHER, WAVE SPRING, CREST-TO-CREST	243
3	-	1	1	1	1	2119083-1	RETAINER, INSULATION DIAL	242
-	1	1	1	1	1	7-18023-7	SCR, SKT HD CAP M3 X 4.0	241
-	-	1	-	1	-	2119580-1	MECHANICAL FEED ASSEMBLY	239
-	1	-	1	-	1	2844940-1	AIR FEED MODULE	238
-	-	-	1	1	-	4-1722335-3	STRIPPER, SIDE FEED	182
-	-	-	1	1	-	1-5018030-0	NUT, HEX, REG, RoHS, M3.5	181
3	-	-	1	1	-	1-1752354-9	STANDOFF,HOLD-DOWN	180
-	-	-	1	1	-	993111-1	PIN, SLOTTED SPRING 3.0 X 20.0	177
-	-	-	1	1	-	5-22280-0	SPRING, COMPRESSION	176
-	-	-	1	1	-	1752353-3	GUIDE PIN,HOLDDOWN	175
-	-	-	1	1	-	1901680-2	GUIDE PIN,HOLDDOWN	174
-	REF	REF	REF	REF	REF	994970-2	COUNTER, MAGNETIC	164
-	1	1	1	1	1	1-22281-8	SPRING, COMPRESSION	121
5	-	1	1	1	1	2119955-1	ASSY, LUBRICATOR, SIDE FEED	113
-	1	1	1	1	1	2844908-1	SCREW, LOCKING	99
-	1	1	1	1	1	2844907-1	POST, LOCKING	98
-	1	1	1	1	1	2-690438-2	FRONT STRIP GUIDE	96
-	2	2	2	2	2	2168083-1	SCR, SKT HD CAP, RoHS, M3 X 8.0	95
-	1	1	1	1	1	2168083-6	SCR, SKT HD CAP, RoHS, M5 X 65	93
-	1	1	1	1	1	455888-5	SPACER, CRIMPER	82
-	1	1	1	1	1	1803607-3	DOCUMENTATION PACKAGE	71
-	1	1	1	1	1	2119791-5	DEPRESSOR, WIRE	70
-	1	1	1	1	1	2119740-1	TAG,IDENTIFICATION	67
-	2	2	2	2	2	2168078-1	SCREW, DRIVE, RH, RoHS, 2 x .188	66
-	1	1	1	1	1	2168083-2	SCR, SKT HD CAP, RoHS, M4 X 8.0	60
-	1	1	1	1	1	5-18022-5	SCR, HEX HD CAP, M4 X 6.0	59
-	1	1	1	1	1	985575-3	SCR, FLT SKT HD CAP M3 X 10.0	57
-	1	1	1	1	1	1338685-1	PAWL, FEED	56
-	4	4	4	4	4	2168083-3	SCR, SKT HD CAP, RoHS, M4 X 12.0	54
-	2	2	2	2	2	1-2168083-0	SCR, SKT HD CAP, RoHS, M4 X 10	53
-	1	1	1	1	1	1803382-6	HOLD DOWN, SPRING LOADED	50
-	1	2	1	2	1	18023-9	SCR, SKT HD CAP M4 X 6.0	49
-	-	1	-	1	-	2119652-1	FEED CAM, PRE FEED	48
-	-	1	-	1	-	2119653-1	FEED CAM, POST FEED	47
-	1	1	-	-	1	1803583-9	APPLICATOR BASIC ASSEMBLY, SF	46
-	1	1	-	-	1	1803515-1	RAM ASSEMBLY, SF ATLANTIC	44
-	1	1	1	1	1	1803602-1	SCR, BHSC, RoHS (M8 X 25)	41
-	1	1	1	1	1	1752356-3	SUPPORT, TERMINAL	34
-	2	2	2	2	2	2079383-5	SCR, BHSC, RoHS (M4 X 20)	33
-	2	2	2	2	2	3-2844962-0	SPACER, CYLINDRICAL, STRIP GUIDE	30
-	1	1	1	1	1	2844938-5	PLATE, STRIP GUIDE	29
-	1	1	1	1	1	455888-3	SPACER, CRIMPER	28
-	1	1	1	1	1	240792-1	DRAG, TERMINAL	25
-	1	1	1	1	1	1320928-6	STRIP GUIDE	24
-	1	1	-	-	1	2168083-2	SCR, SKT HD CAP, RoHS, M4 X 8.0	21
-	2	2	1	1	2	1-18028-2	WASHER, FLAT, REG M4	20
-	1	1	-	-	1	2119533-1	STRIPPER, SIDE FEED	19
1	1	1	1	1	1	2119806-1	INSERT, SHEAR	13
-	1	1	1	1	1	3-22280-3	SPRING, COMPRESSION	12
-	1	1	1	1	1	1-356885-4	STOP, SHEAR	11
1	1	1	1	1	1	2119805-1	SHEAR HOLDER, FRONT	10
1	1	1	1	1	1	318707-1	FLOATING SHEAR, FRONT	9
1	2	2	1	1	1	1-1633918-6	ANVIL, COMBINATION	8
-	1	1	1	1	1	3-240641-8	SPACER	7
-	-	-	-	-	-	-	-	6
-	1	1	1	1	1	2119781-1	DEPRESSOR, SHEAR	5
-	1	1	1	1	1	3-238011-3	BLOCK, CRIMPER SPACER	4
1	1	2	2	1	1	6-1633965-1	CRIMPER, INSULATION O PREMIUM	3
-	1	1	1	1	1	455888-4	SPACER, CRIMPER	2
1	2	2	1	1	1	8-1633609-5	CRIMPER, WIRE	1

ATLANTIC VERSION  
 Shown on sheets 1 of 4 & 2 of 4  
 (Pacific version shown on sheets 3 of 4 & 4 of 4)

DIMENSIONS:	TOLERANCES UNLESS OTHERWISE SPECIFIED:	DATE	BY	CHK	APPV	NAME
mm	0 PLC ± 1 PLC ± 2 PLC ± 3 PLC ± 4 PLC ± ANGLES ±	19 JUL 2013	U GUO	U GUO	U GUO	TE Connectivity Harrisburg, PA 17105-3608
MATERIAL:		WEIGHT:		SCALE:		RESTRICTED TO:
FINISH:		Customer Accessible Production Drawing		SCALE: 1:2		SHEET 1 OF 4

LOC	DIST	REV	DATE	BY	APPV
A	66				

# FEED TYPE MECHANICAL

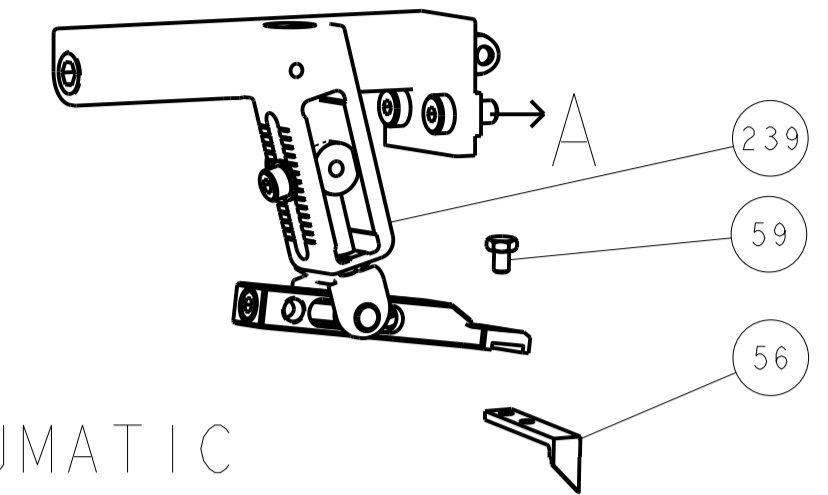

## PNEUMATIC

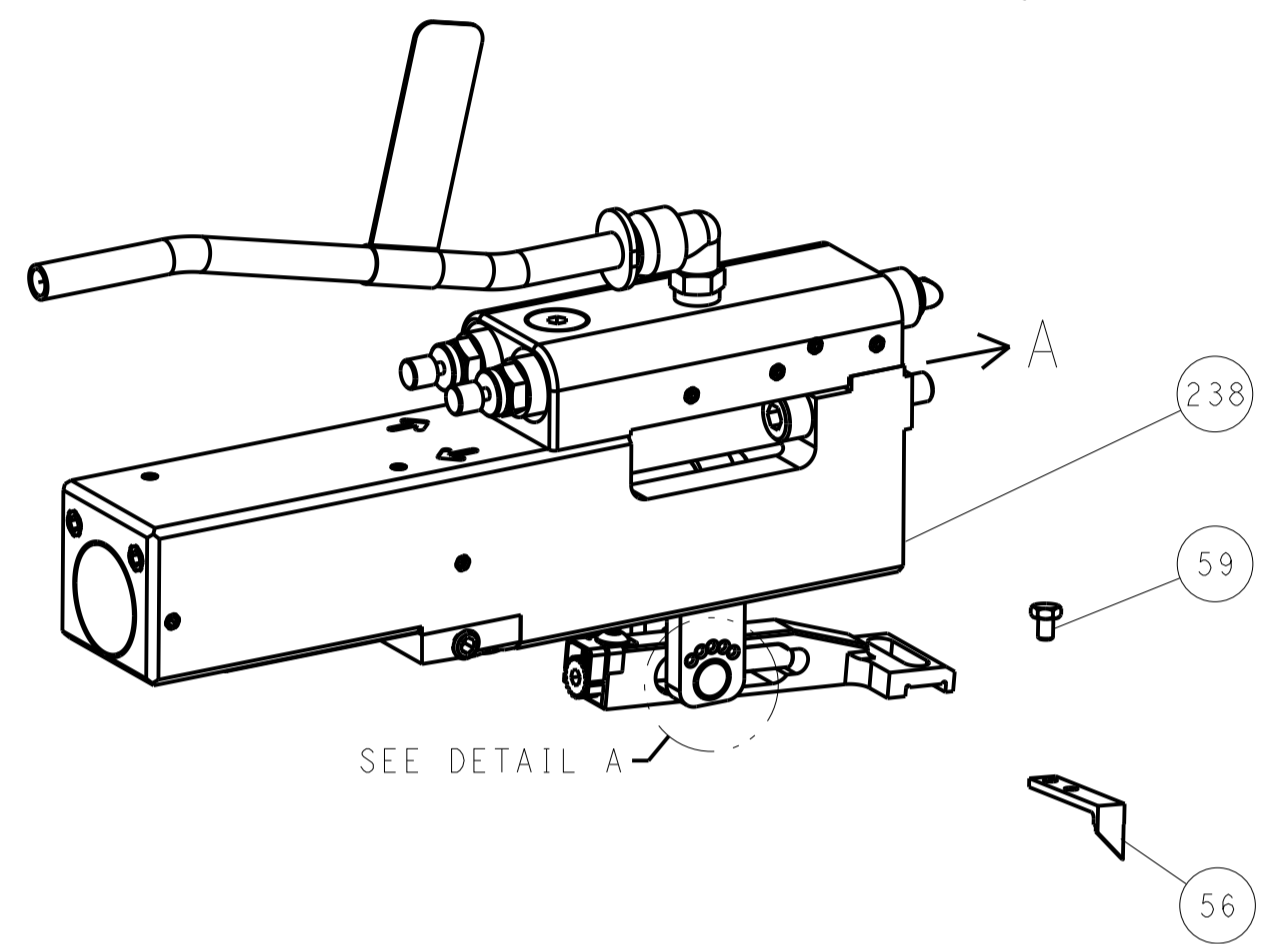

## FEED SPRING SETTING POSITION (SHOWN FROM REAR SIDE)

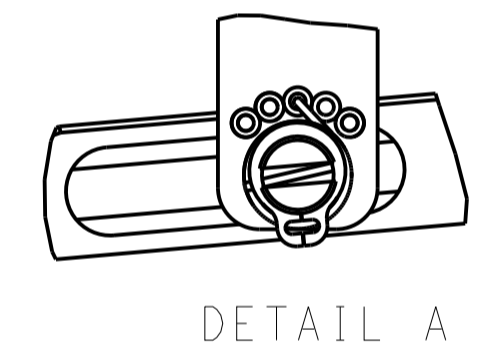

DETAIL A

# CAM POSITIONS

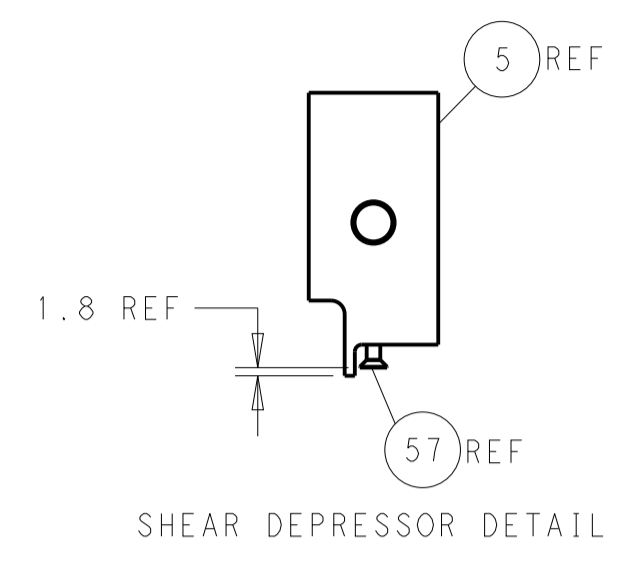
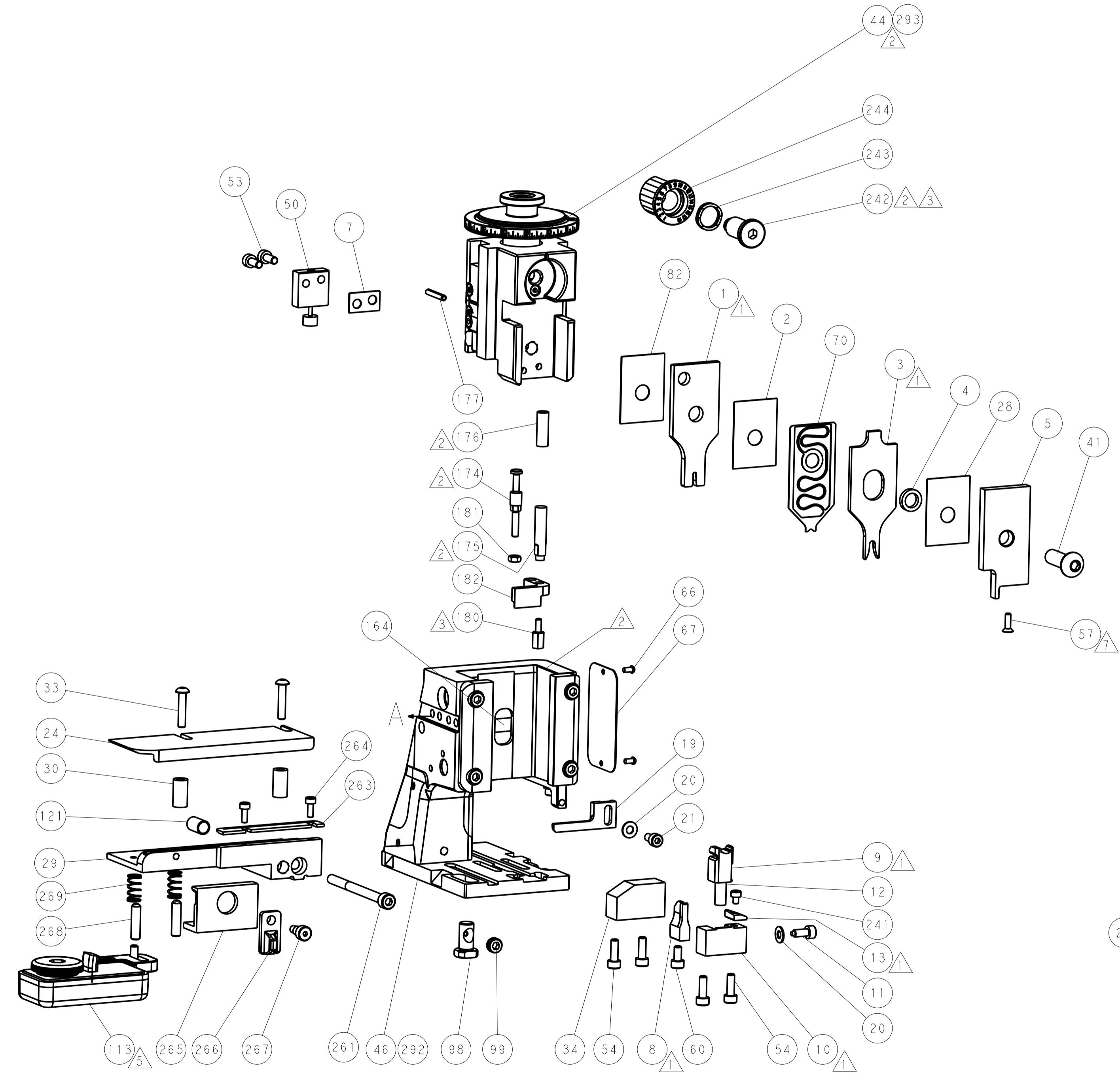
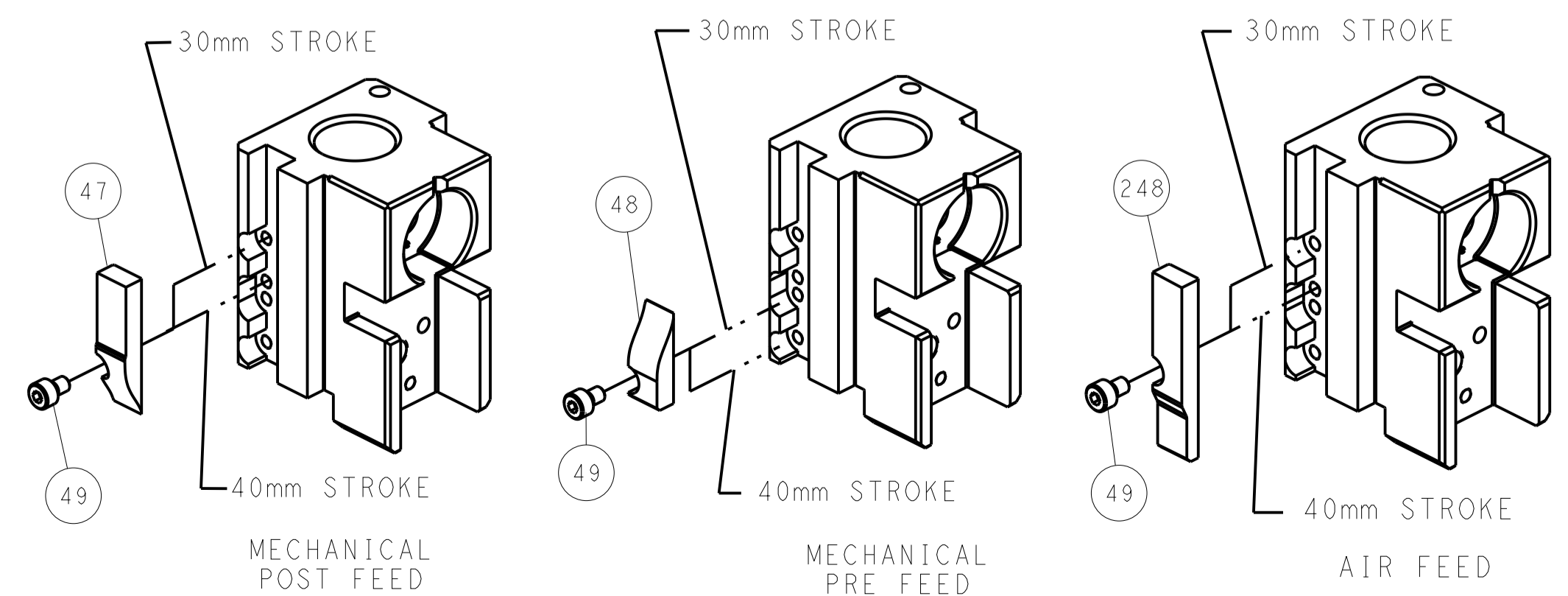

SHEAR DEPRESSOR DETAIL

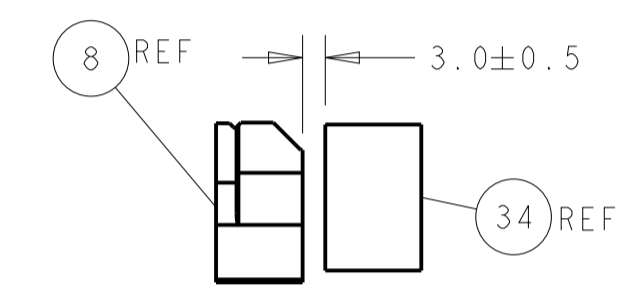

TERMINAL SUPPORT LOCATION

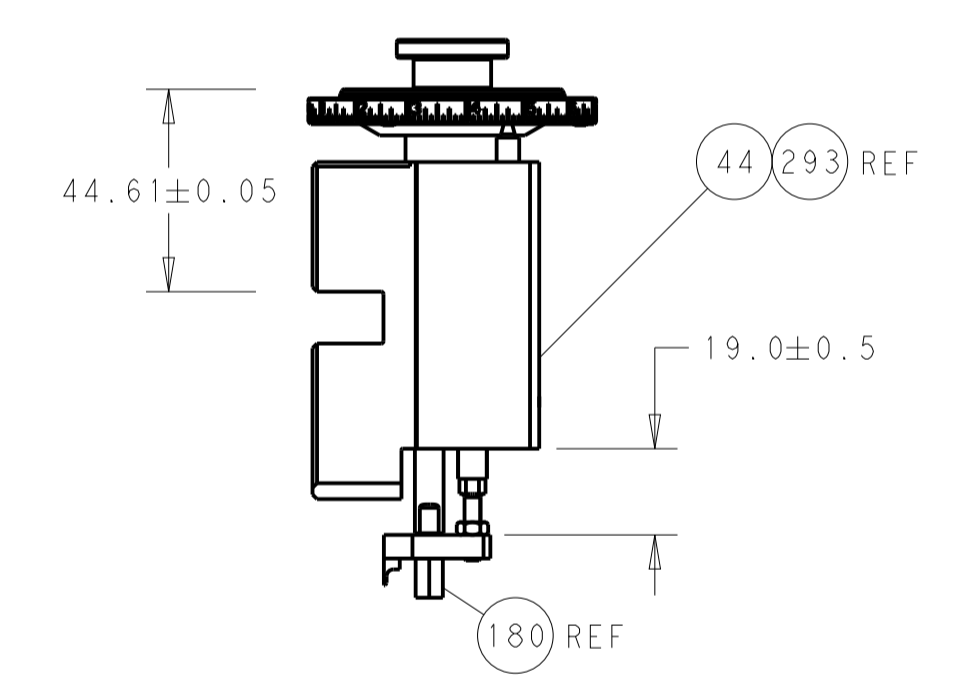

RAM AND HOLDDOWN SET-UP

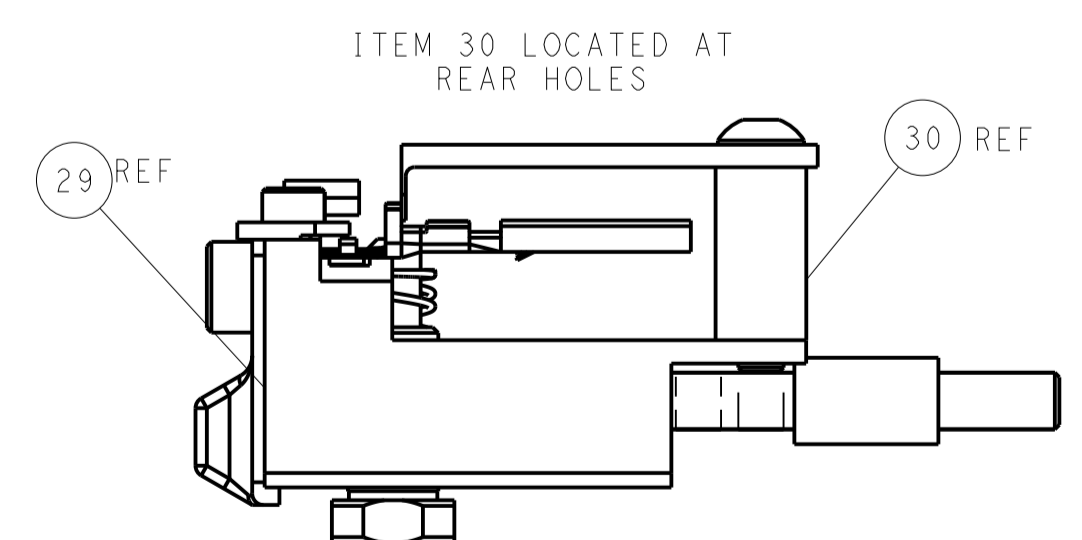

FEED TRACK POSITION GUIDE BY INSULATION BARREL

**ATLANTIC VERSION**  
 Shown on sheets 1 of 4 & 2 of 4  
 (Pacific version shown on sheets 3 of 4 & 4 of 4)

DIMENSIONS:		TOLERANCES UNLESS OTHERWISE SPECIFIED:		DWG: C. CHEN 19JUL2013		TE Connectivity	
mm	0 PLC ±	1 PLC ±	2 PLC ±	3 PLC ±	4 PLC ±	APVD: U. GUO 19JUL2013	Harrisburg, PA 17105-3608
	ANGLES ±			NAME: Ocean Side Feed Applicator		RESTRICTED TO	
MATERIAL:	FINISH:	WEIGHT:	SCALE: 1:2	SHEET: 2 OF 4	REV: E	Customer Accessible Production Drawing	

PART NUMBER	REVISION	DESCRIPTION	FEED TYPE
2-2266002-1	E	FINE CRIMP HEIGHT ADJUST	MECHANICAL
2-2266002-2	E	FINE CRIMP HEIGHT ADJUST	PNEUMATIC
7-2266002-7	C	CRIMP TOOLING KIT	-

PACIFIC VERSION TERMINATOR  
INTERFACE ADAPTER

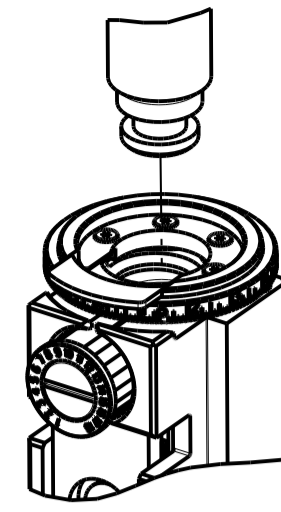

APPLICATOR DATA		
CRIMP	SIZE	TYPE
WIRE	1.57 mm [.062]	F
INSUL	3.35 mm [.132]	O
APPLICATOR INSTRUCTIONS 408-35042		

TERMINAL DATA: MOLEX(FORD) TERMINAL MOLEX CRIMP SPECIFICATION

TERMINAL NAME: TERMINAL

WIRE STRIP LENGTH	INSULATION DIAMETER RANGE
4.30-5.00 mm [1.69-.197 IN]	Ø1.40-1.70 mm [0.055-.067 IN]

TERMINAL APPLICATION SPECIFICATION: ATS-639017400 Rev B, AUST-14421-AA Rev B3

TERMINALS APPLIED

TE TERMINAL	MOLEX(FORD) TERMINAL	TE SEAL	MOLEX(FORD) SEAL	CABLE DIAMETER
2113354-1	34080-1106 (BUST-14421-FA)	1949248-1	97BG-10C930-SBA	Ø1.19-16.5mm
2113354-2	34080-1003 (AUST-14421-AA)		OSR SEAL	
2113354-3	34080-1206 (BUST-14421-CA)	2113614-1	E-1644-01	
		2113406-1	A-0370B	

WIRE SIZE	CRIMP HEIGHT mm [INCH]	CRIMP HEIGHT REFERENCE SETTING
0.50mm2	1.10+/-0.05 [0.043+/-0.002]	7.2
22AWG or 0.35mm2	1.00+/-0.05 [0.039+/-0.002]	8.3



- RECOMMENDED SPARE PARTS
- REFER TO SUPPLIED INSTRUCTION SHEET FOR CLEANING, LUBRICATION AND STORAGE OF APPLICATOR.
- APPLY PART NUMBER 2-23419-6 LOCTITE TO THREADS OF ITEM 242.
- CRIMP HEIGHT REFERENCE SETTING WAS THE SETTING USED WHEN THE APPLICATOR WAS QUALIFIED AT THE FACTORY. ADJUSTMENT MAY BE NECESSARY WHEN RUNNING APPLICATOR IN THE FIELD.
- TERMINAL LUBRICANT IS RECOMMENDED.
- UNLESS SPECIFIED OTHERWISE TORQUE VALUES SHALL BE USED PER DOCUMENT, 101-35000.
- APPLY TORO-SEAL IN ALLEN SOCKET TO FILL HOLE AFTER FLAT HD HAS BEEN ADJUSTED TO CORRECT HEIGHT AT QUALIFICATION. APPLY #1-23419-5 LOC-TITE TO THREADS.

**\*WARNING**  
ON INSTALLATION, SET WIRE DISC TO CRIMP HEIGHT REFERENCE SETTING FOR LARGEST WIRE SIZE. CRIMP HEIGHT REFERENCE SETTINGS GREATER THAN THE VALUE SHOWN MAY CAUSE DAMAGE TO THE CRIMP TOOLING. REFER TO THE INSTRUCTION SHEET FOR PROPER SETUP AND ADJUSTMENTS.

LOC	DIST	REV	DATE	BY	APPV
A	66				

REV	DATE	DESCRIPTION	DATE	BY	APPV
-	2	22281-8			
-	2	2-18032-5			
-	1	980371-4			
-	1	356835-1			
-	1	2119082-7			
-	1	2079764-1			
-	1	2119083-1			
-	1	7-18023-7			
-	-	2119580-1			
-	1	2844940-1			
-	REF	REF			
-	1	994970-2			
-	1	2119641-2			
-	1	2168083-8			
-	4	2168083-9			
-	-	2119653-2			
-	1	1-1803583-0			
-	1	1803516-1			
-	1	1-22281-8			
-	1	2119955-1			
-	1	2844908-1			
-	1	2844907-1			
-	1	2-690438-2			
-	2	2168083-1			
-	1	2168083-6			
-	1	455888-5			
-	1	1803607-3			
-	1	2119791-5			
-	1	2119740-1			
-	2	2168078-1			
-	1	5-18022-5			
-	1	985575-3			
-	1	1338685-1			
-	2	1-2168083-0			
-	1	1803382-6			
-	1	18023-9			
-	-	2119652-1			
-	1	1803602-1			
-	1	1752356-3			
-	2	2079383-5			
-	2	3-2844962-0			
-	1	2844938-5			
-	1	455888-3			
-	1	240792-1			
-	1	1320928-6			
-	1	2168083-2			
-	2	1-18028-2			
-	1	2119533-1			
-	1	2119806-1			
-	1	3-22280-3			
-	1	1-356885-4			
-	1	2119805-1			
-	1	318707-1			
1	1	1-1633918-6			
-	1	3-240641-8			
-	-	-			
-	1	2119781-1			
-	1	3-238011-3			
1	1	6-1633965-1			
-	1	455888-4			
1	1	8-1633609-5			

DIMENSIONS:		TOLERANCES UNLESS OTHERWISE SPECIFIED:		MATERIAL:		FINISH:	
mm	0 PLC ±	1 PLC ±	2 PLC ±	3 PLC ±	4 PLC ±	ANGLES	

PACIFIC VERSION  
Shown on sheets 3 of 4 & 4 of 4  
(Atlantic version shown on sheets 1 of 4 & 2 of 4)

LOC	DIST	REVISIONS			
A	66	REV	DATE	BY	APPV
-	-	SEE SHEET 1	-	-	-

# FEED TYPE MECHANICAL

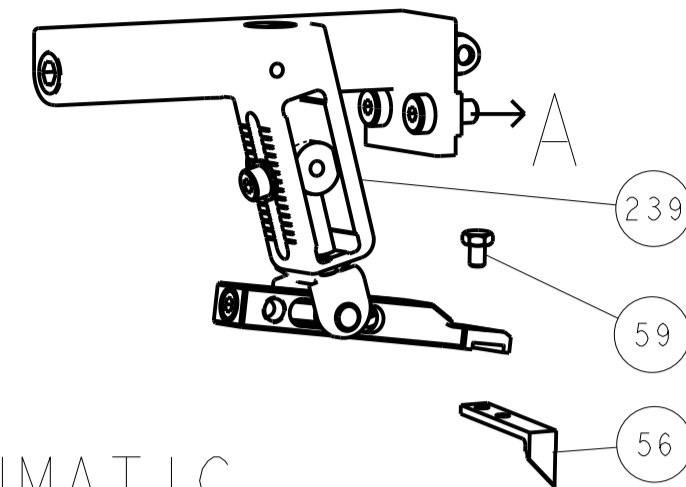

## PNEUMATIC

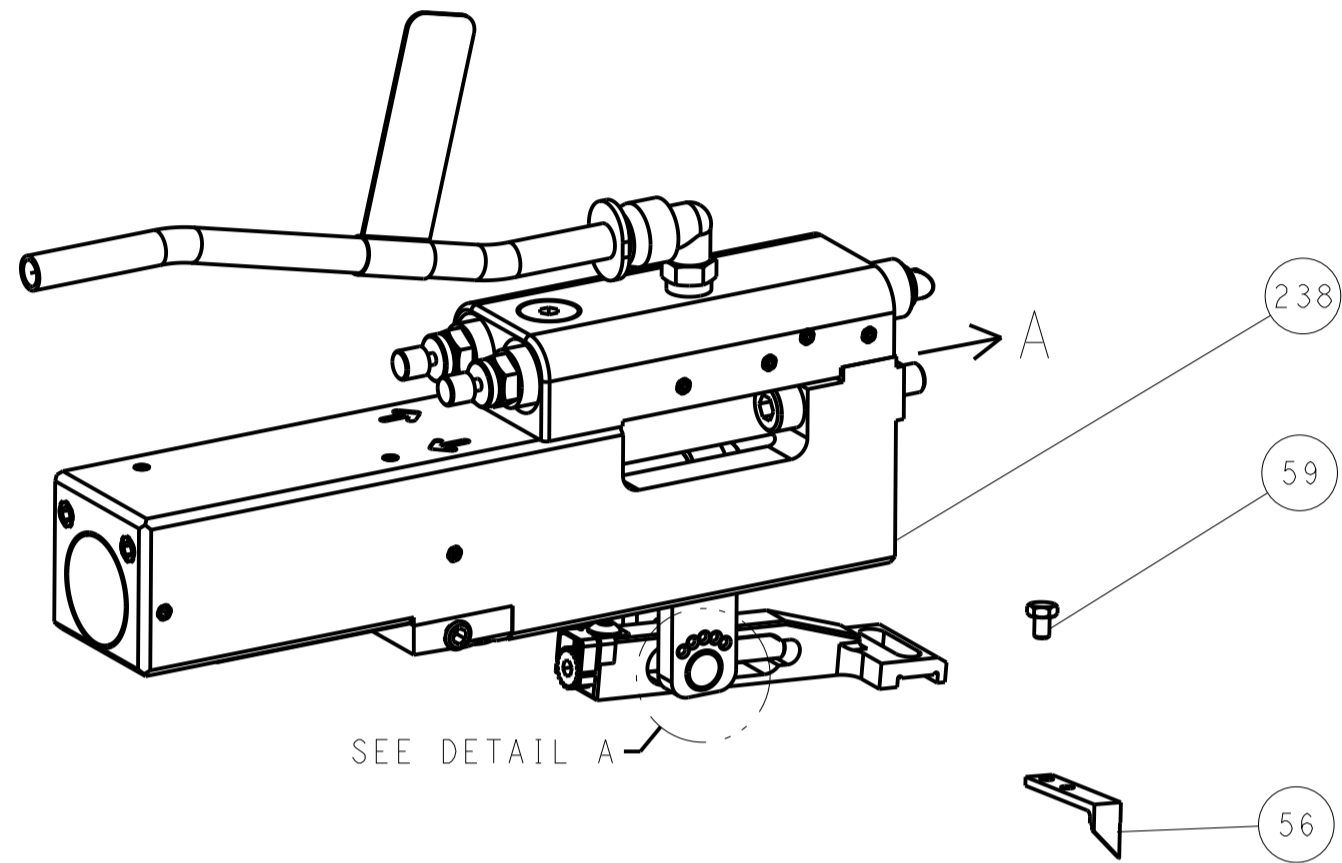

### FEED SPRING SETTING POSITION (SHOWN FROM REAR SIDE)

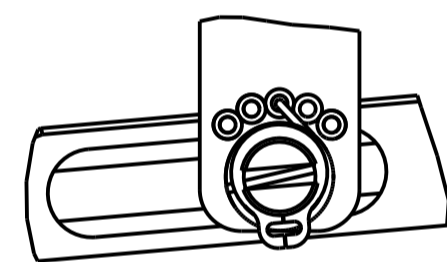

DETAIL A

## CAM POSITIONS

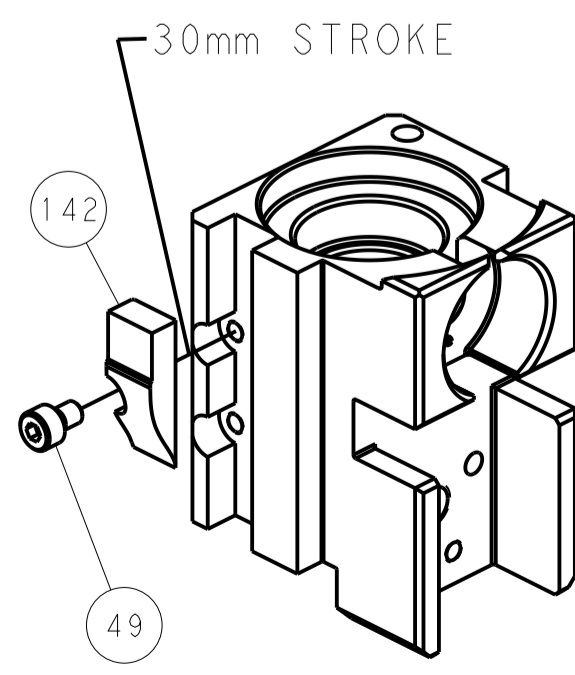

MECHANICAL  
POST FEED

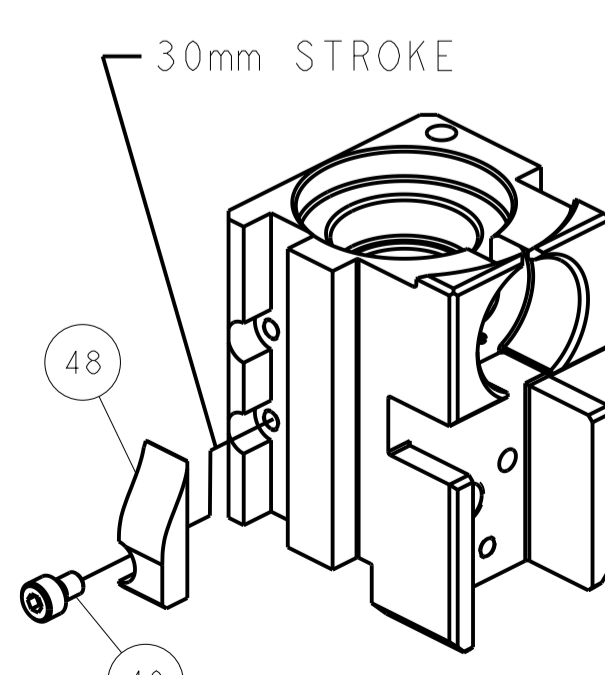

MECHANICAL  
PRE FEED

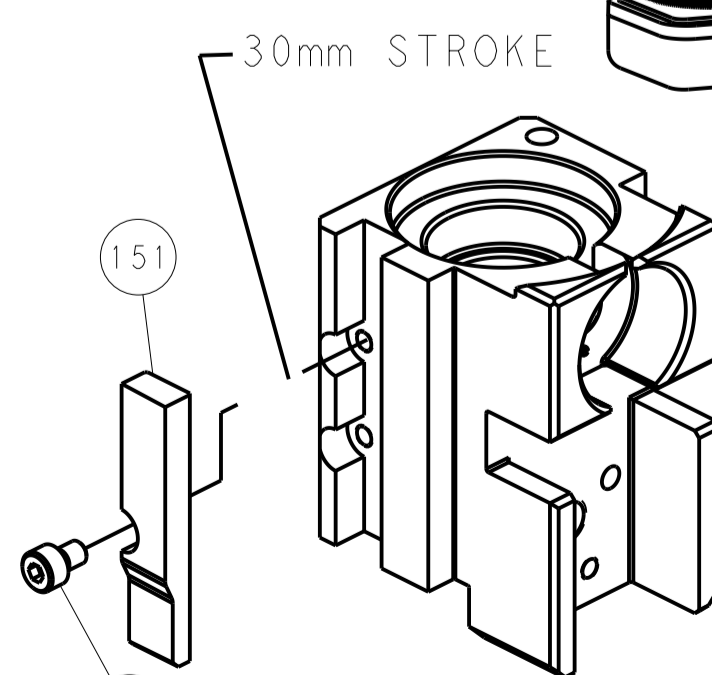

AIR FEED

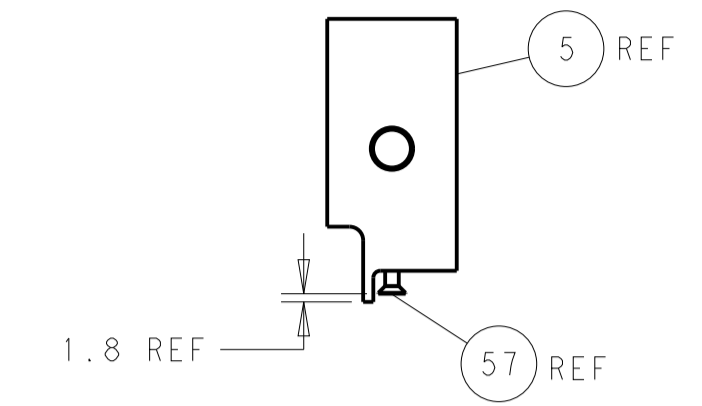
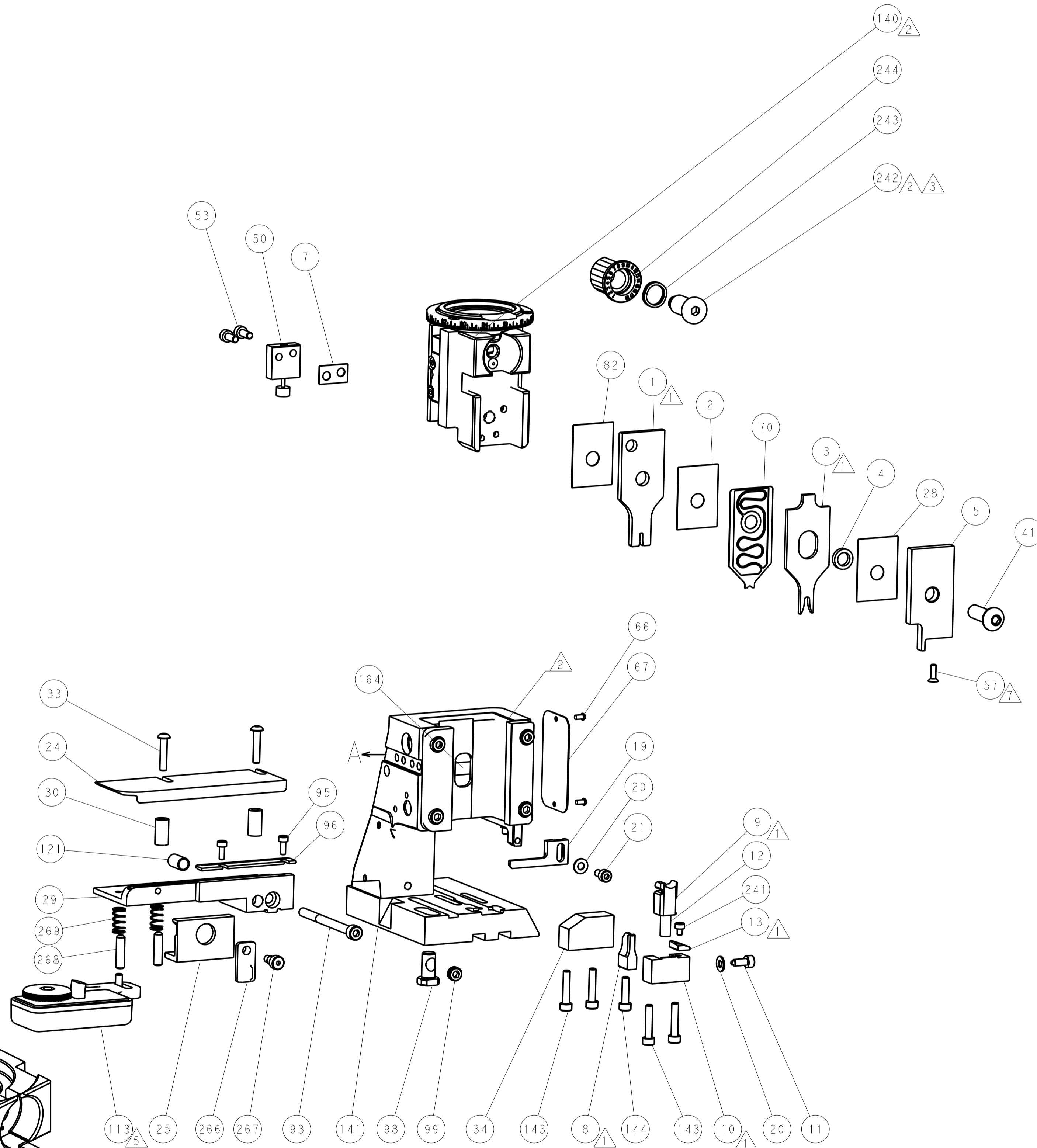

SHEAR DEPRESSOR DETAIL

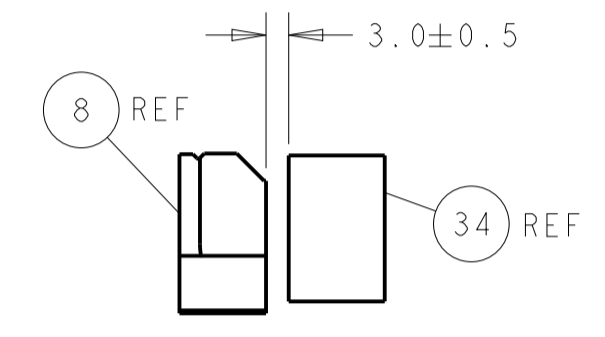

TERMINAL SUPPORT LOCATION

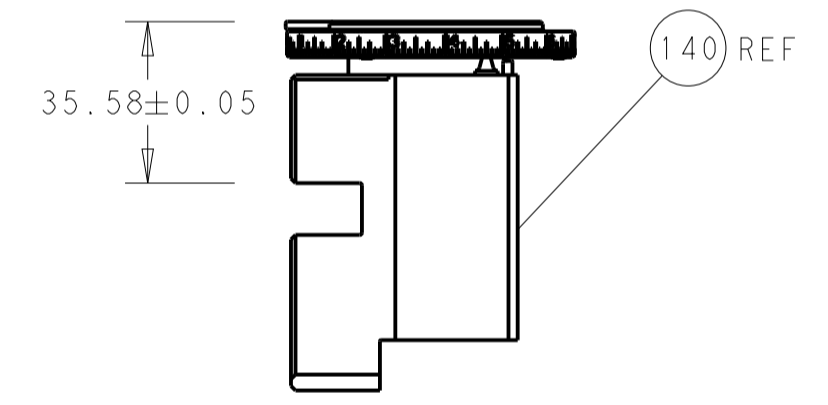

RAM SET-UP

ITEM 30 LOCATED AT  
REAR HOLES

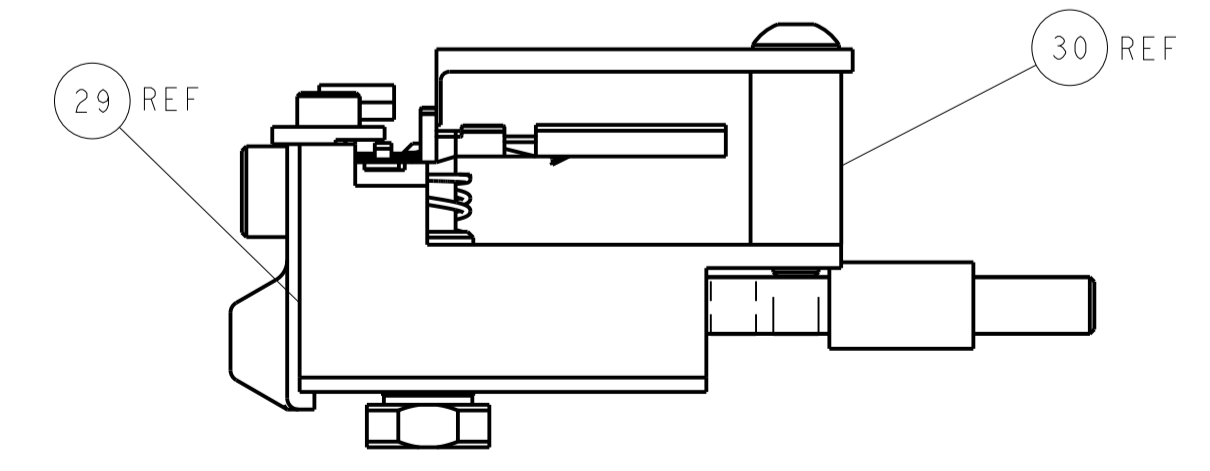

FEED TRACK POSITION  
GUIDE BY INSULATION BARREL

**PACIFIC VERSION**  
 Shown on sheets 3 of 4 & 4 of 4  
 (Atlantic version shown on sheets 1 of 4 & 2 of 4)

DIMENSIONS:		TOLERANCES UNLESS OTHERWISE SPECIFIED:		DWG: C. CHEN 19JUL2013		REV: U. GUO 19JUL2013		NAME: Ocean Side Feed Applicator	
mm	0 PLC	±		PRODUCT SPEC	APVD: J. CRUZ 19JUL2013	SIZE: A1	CAGE CODE: 00779	DRAWING NO: C=2266002	RESTRICTED TO: -
	1 PLC	±		APPLICATION SPEC	WEIGHT: -	SCALE: 1:2	SHEET: 4	OF: 4	REV: E
	2 PLC	±							
	3 PLC	±							
	4 PLC	±							
	ANGLES	±							
MATERIAL:	FINISH:								