

© 2021 TE Connectivity. All Rights Reserved.

PART NUMBER	REV	DESCRIPTION
2234155-1	A	HV DIE SET
7-2234155-7	A	CRIMP TOOLING KIT
9-2234155-1	A	DIE SET WITH DIE HOLDER

# OBSOLETE

REVISIONS					
P	LTR	DESCRIPTION	DATE	DWN	APVD
A		RELEASED	08OCT2019	LG	TE
A1		ECR-20-012009	04SEP2020	AJ	YY
A2		ECR-21-006246	15JUN2021	JL	YY
A3		OBSOLETE PER ECR-21-119886	09NOV2021	JL	YY

TERMINAL NAME	OUTER FERRULE HVA630 MULTI-CORE		
TERMINAL PART NUMBER	2141617-1   2141261-1   2141616-1		
APPLICATION SPECIFICATION	114-94114		
REFERENCE DRAWING	C-114-94114-1		
USED ON	2305470-1	2326378-1	
INSTRUCTION SHEET	408-35079		

CABLE SUPPLIER/SPECIFICATION	CABLE SIZE	CRIMP HEIGHT	CRIMP HEIGHT REFERENCE SETTING
COROPLAST 9-2641	5 x 6.0mm <sup>2</sup>	16.4±0.3	C7
	3 x 4.0/4 x 4.0mm <sup>2</sup>		

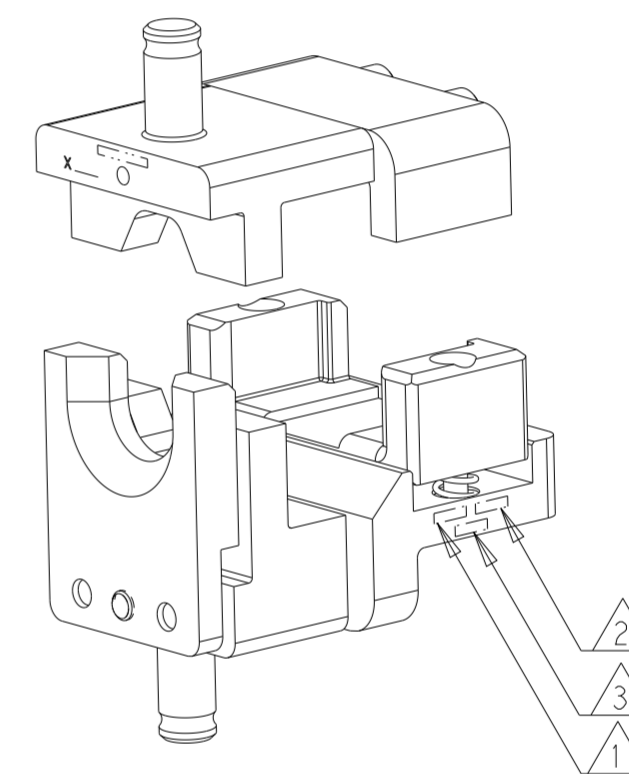
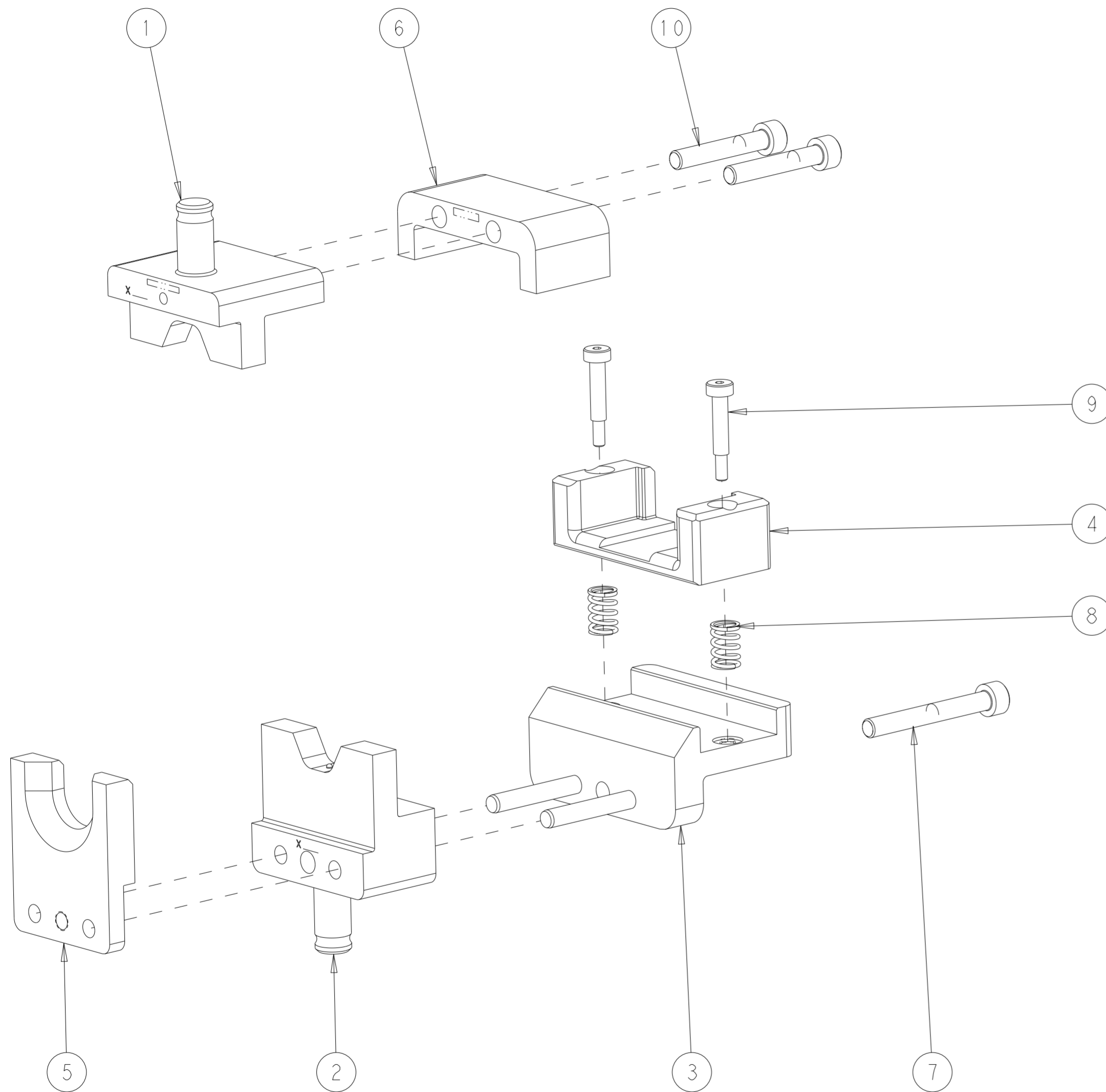

1	-	-	2305470-1	HV DIE HOLDER WITH FINE ADJUST	100
2	-	2	2-18023-3	SCR, SKT HD CAP M5 X 30.0	10
2	-	2	2-993127-2	SCR, SKT HD SHLDR 4.0 DIA X 16.0	9
2	-	2	3-22281-5	SPRING, COMPRESSION	8
1	-	1	2-18023-4	SCR, SKT HD CAP M5 X 40.0	7
1	-	1	2234129-2	TERMINAL HOLD DOWN	6
1	-	1	2234127-3	REAR LOCATOR, FERRULE	5
1	-	1	2234128-2	BLOCK, TERMINAL	4
1	-	1	2326504-3	HOUSING, LOCATOR	3
1	1	1	2326501-5	NEST HVM HEX	2
1	1	1	2326502-5	CRIMPER HVM HEX	1
-91	-77	-1	PART NO	DESCRIPTION	ITEM NO

- 1 APPLY "DIE SET PN" PER TEC-115-67-2 IN APPROXIMATE AREA SHOWN.
- 2 IDENTIFY PART NUMBER AND REVISION LETTER PER TEC-115-67-2 IN APPROXIMATE AREA SHOWN.
- 3 IDENTIFY SERIAL NUMBER PER TEC-115-67-2 IN APPROXIMATE AREA SHOWN.
- 4. TORQUE RECOMMENDATIONS PER 101-35000 UNLESS OTHERWISE SPECIFIED.

THIS DRAWING IS A CONTROLLED DOCUMENT.

DWN K HUANG	04JUL2019	 TE Connectivity
CHK K HUANG	04JUL2019	
APVD Y YIN	04JUL2019	
PRODUCT SPEC		
MATERIAL		NAME DIE SET HVA630 4.0mm <sup>2</sup> /6.0mm <sup>2</sup> FERRULE
DIMENSIONS: MM		SIZE A2
TOLERANCES UNLESS OTHERWISE SPECIFIED:		CAGE CODE 00779
0 PLC ±		DRAWING NO C-2234155
1 PLC ±		RESTRICTED TO
2 PLC ±		
3 PLC ±		
4 PLC ±		
ANGLES ±		
FINISH		
CUSTOMER ACCESSIBLE PRODUCTION DRAWING		SCALE 1:1
		SHEET 1 OF 1
		REV A3