

PART NUMBER	REVISION	DESCRIPTION	FEED TYPE
2151154-1	E	FINE CRIMP HEIGHT ADJUST	MECHANICAL
2151154-2	E	FINE CRIMP HEIGHT ADJUST	PNEUMATIC
5-2151154-1	E	SEAL STRIPPER CRIMPER TERMINATING UNIT	MECHANICAL
5-2151154-2	E	SEAL STRIPPER CRIMPER TERMINATING UNIT	PNEUMATIC
7-2151154-1	E	MECHANICAL AND CRIMP TOOLING KIT	MECHANICAL
7-2151154-2	E	PNEUMATIC AND CRIMP TOOLING KIT	PNEUMATIC
7-2151154-7	A	CRIMP TOOLING KIT	-

ATLANTIC VERSION TERMINATOR INTERFACE ADAPTER



APPLICATOR DATA

CRIMP	SIZE	TYPE
WIRE	2.79 mm [.110]	F
INSUL	3.56 mm [.140]	OV

APPLICATOR INSTRUCTIONS 408-35042

TERMINAL DATA: TE TERMINAL TE CRIMP SPECIFICATION

TERMINAL NAME: JUNIOR POWER TIMER CONTACT

WIRE STRIP LENGTH	INSULATION DIAMETER RANGE
4.00-4.60 mm [.157-.181 IN]	Ø2.10-3.10 mm [.083-.122 IN]

TERMINAL APPLICATION SPECIFICATION 114-18050

TERMINALS APPLIED

TE TERMINAL	TE TERMINAL	TE TERMINAL	TE TERMINAL
927768-1	927768-9	963884-2	963973-1
927768-2	1-927768-1	965899-1	963973-3
927768-3	2-927768-1	965899-2	1-963973-1
927768-6	963884-1	9-965899-1	2-963973-1
927768-8			

TERMINAL DATA: TE TERMINAL TE CRIMP SPECIFICATION

TERMINAL NAME: JUNIOR POWER TIMER CONTACT

WIRE STRIP LENGTH	INSULATION DIAMETER RANGE
4.00-4.60 mm [.157-.181 IN]	Ø1.90-2.10 mm [.075-.083 IN]

TERMINAL APPLICATION SPECIFICATION 114-18050

TERMINALS APPLIED

TE TERMINAL	TE TERMINAL	TE TERMINAL	TE TERMINAL
927768-1	927768-9	963884-2	963973-1
927768-2	1-927768-1	965899-1	963973-3
927768-3	2-927768-1	965899-2	1-963973-1
927768-6	963884-1	9-965899-1	2-963973-1
927768-8			

WIRE SIZE	CRIMP HEIGHT mm [INCH]	CRIMP HEIGHT REFERENCE SETTING
2.50mm2	1.77+/-0.05 [.070+/- .002]	8.0
2.00mm2	1.64+/-0.05 [.065+/- .002]	9.5
1.50mm2	1.51+/-0.05 [.059+/- .002]	10.7

WIRE SIZE	CRIMP HEIGHT mm [INCH]	CRIMP HEIGHT REFERENCE SETTING
2X1.00mm2	1.58+/-0.05 [.062+/- .002]	10.1
2X 0.75mm2	1.51+/-0.05 [.059+/- .002]	10.7
0.75 + 0.50mm2	1.40+/-0.05 [.055+/- .002]	11.5



- 1 RECOMMENDED SPARE PARTS
- 2 REFER TO SUPPLIED INSTRUCTION SHEET FOR CLEANING, LUBRICATION AND STORAGE OF APPLICATOR.
- 3 APPLY PART NUMBER 1-23419-5 LOCTITE TO THREADS OF ITEMS 180. APPLY PART NUMBER 2-23419-6 LOCTITE TO THREADS OF ITEM 242.
- 4 CRIMP HEIGHT REFERENCE SETTING WAS THE SETTING USED WHEN THE APPLICATOR WAS QUALIFIED AT THE FACTORY. ADJUSTMENT MAY BE NECESSARY WHEN RUNNING APPLICATOR IN THE FIELD.
- 5 UNLESS SPECIFIED OTHERWISE TORQUE VALUES SHALL BE USED PER DOCUMENT, 101-35000.

***WARNING**
ON INSTALLATION, SET WIRE DISC TO CRIMP HEIGHT REFERENCE SETTING FOR LARGEST WIRE SIZE. CRIMP HEIGHT REFERENCE SETTINGS GREATER THAN THE VALUE SHOWN MAY CAUSE DAMAGE TO THE CRIMP TOOLING, REFER TO THE INSTRUCTION SHEET FOR PROPER SETUP AND ADJUSTMENTS.

6 THIS CRIMP PARAMETER IS PROVIDED TO MEET A CUSTOM AND UNIQUE CUSTOMER REQUIREMENT. IT HAS BEEN EVALUATED AND IS CONDITIONALLY SPECIFIED BY TE CONNECTIVITY. THIS CUSTOMIZED CRIMP PARAMETER IS NOT LISTED AS AN APPROVED APPLICATION WITHIN A TE CONNECTIVITY APPLICATION SPECIFICATION; HOWEVER, IT HAS BEEN VALIDATED ACCORDING TO TE CONNECTIVITY SPECIFICATIONS 109-18079 (TEST GROUP 1) AND 114-18022. **TE CONNECTIVITY EXPRESSLY DISCLAIMS ANY AND ALL WARRANTIES THAT THE PRODUCT WILL PERFORM SIMILARLY TO VALIDATED AND APPROVED APPLICATIONS, AS STATED WITHIN TE CONNECTIVITY APPLICATION SPECIFICATIONS, INCLUDING BUT NOT LIMITED TO IMPLIED WARRANTIES OF MERCHANTABILITY OR FITNESS FOR PARTICULAR PURPOSE.** AS SUCH, IT IS HIGHLY RECOMMENDED THAT THE CUSTOMER PERFORM FURTHER DETAILED EVALUATION TO ASSESS PRODUCT PERFORMANCE IN THE SPECIFIC APPLICATION.

ATLANTIC VERSION
Shown on sheets 1 of 4 & 2 of 4
(Pacific version shown on sheets 3 of 4 & 4 of 4)

LOC	DIST	REV	DATE	BY	CHKD	APPD
A	66	C1	07DEC2018	MZ	TE	
		C2	17MAY2019	LG	TE	
		D	04JUN2021	FJ	TE	
		E	04JAN2022	JWC	GB	

REV	DATE	BY	CHKD	APPD	DESCRIPTION	ITEM NO		
-	-	-	1	1	-	1803515-3 RAM ASSEMBLY, SF ATLANTIC	293	
-	-	-	1	1	-	2-1803583-1 APPLICATOR BASIC ASSEMBLY, SF	292	
-	1	-	1	-	1	2119641-1 FEED CAM, AIR FEED	248	
-	1	1	1	1	1	2119082-9 CAM, SNAIL, INSULATION ADJUSTMENT	244	
-	1	1	1	1	1	2079764-1 WASHER, WAVE SPRING, CREST-TO-CREST	243	
-	1	1	1	1	1	2119083-1 RETAINER, INSULATION DIAL	242	
-	1	1	1	1	1	7-18023-7 SCR, SKT HD CAP M3 X 4.0	241	
-	-	1	-	1	-	2119580-1 MECHANICAL FEED ASSEMBLY	239	
-	1	-	1	-	1	2844940-1 AIR FEED MODULE	238	
-	-	-	1	1	-	4-1722335-3 STRIPPER, SIDE FEED	182	
-	-	-	1	1	-	1-5018030-0 NUT, HEX, REG, RoHS, M3.5	181	
-	-	-	1	1	-	2-1752354-4 STANDOFF,HOLD-DOWN	180	
-	-	-	1	1	-	9931111-1 PIN, SLOTTED SPRING 3.0 X 20.0	177	
-	-	-	1	1	-	5-22280-0 SPRING, COMPRESSION	176	
-	-	-	1	1	-	1752353-3 GUIDE PIN,HOLDDOWN	175	
-	-	-	1	1	-	1901680-2 GUIDE PIN,HOLDDOWN	174	
-	REF	REF	REF	REF	REF	994970-2 COUNTER, MAGNETIC	164	
-	1	1	1	1	1	2844908-1 SCREW, LOCKING	99	
-	1	1	1	1	1	2844907-1 POST, LOCKING	98	
-	1	1	1	1	1	455888-5 SPACER, CRIMPER	82	
-	1	1	1	1	1	1803607-3 DOCUMENTATION PACKAGE	71	
-	1	1	1	1	1	2119740-1 TAG,IDENTIFICATION	67	
-	2	2	2	2	2	2168078-1 SCREW, DRIVE, RH, RoHS, 2 x .188	66	
-	1	1	1	1	1	2168083-2 SCR, SKT HD CAP, RoHS, M4 X 8.0	60	
-	1	1	1	1	1	5-18022-5 SCR, HEX HD CAP, M4 X 6.0	59	
-	1	1	1	1	1	1338685-1 PAWL, FEED	56	
-	4	4	4	4	4	2168083-3 SCR, SKT HD CAP, RoHS, M4 X 12.0	54	
-	2	2	2	2	2	1-2168083-0 SCR, SKT HD CAP, RoHS, M4 X 10	53	
-	1	1	1	1	1	1803382-6 HOLD DOWN, SPRING LOADED	50	
-	1	2	1	2	1	2	18023-9 SCR, SKT HD CAP M4 X 6.0	49
-	-	1	-	1	-	1	2119652-1 FEED CAM, PRE FEED	48
-	-	1	-	1	-	1	2119653-1 FEED CAM, POST FEED	47
-	1	1	-	-	1	1	1803583-9 APPLICATOR BASIC ASSEMBLY, SF	46
-	1	1	-	-	1	1	1803515-1 RAM ASSEMBLY, SF ATLANTIC	44
-	1	1	1	1	1	1	1803602-1 SCR, BHSC, RoHS (M8 X 25)	41
-	1	1	1	1	1	1	3-1752356-3 SUPPORT, TERMINAL	34
-	2	2	2	2	2	2	2079383-5 SCR, BHSC, RoHS (M4 X 20)	33
-	2	2	2	2	2	2	3-2844962-0 SPACER, CYLINDRICAL, STRIP GUIDE	30
-	1	1	1	1	1	1	2844992-2 ASSEMBLY, STRIP GUIDE	29
-	1	1	1	1	1	1	1-455888-0 SPACER, CRIMPER	28
-	1	1	1	1	1	1	1320928-2 STRIP GUIDE	24
-	1	1	-	-	1	1	2168083-2 SCR, SKT HD CAP, RoHS, M4 X 8.0	21
-	2	2	1	1	2	2	1-18028-2 WASHER, FLAT, REG M4	20
-	1	1	-	-	1	1	2119533-1 STRIPPER, SIDE FEED	19
-	1	1	1	1	1	1	2119806-1 INSERT, SHEAR	13
-	1	1	1	1	1	1	3-22280-3 SPRING, COMPRESSION	12
-	1	1	1	1	1	1	1-356885-4 STOP, SHEAR	11
-	1	1	1	1	1	1	2119805-1 SHEAR HOLDER, FRONT	10
-	1	1	1	1	1	1	1803095-1 FLOATING SHEAR, FRONT	9
-	1	2	2	1	1	1	3-1333207-9 ANVIL, COMBINATION .110	8
-	1	1	1	1	1	1	6-240641-7 SPACER	7
-	1	1	1	1	1	1	2119757-8 DEPRESSOR, SHEAR	5
-	1	1	1	1	1	1	2-238011-2 BLOCK, CRIMPER SPACER	4
-	1	2	2	1	1	1	1-2119785-1 CRIMPER, INSULATION OVERLAP PREMIUM	3
-	1	1	1	1	1	1	455888-2 SPACER, CRIMPER	2
-	1	2	2	1	1	1	456408-2 CRIMPER, WIRE PREMIUM	1

REV	DATE	BY	CHKD	APPD	DESCRIPTION	ITEM NO			
-77	-72	-71	-52	-51	-2	-1	PART NO	DESCRIPTION	ITEM NO
DIMENSIONS: mm TOLERANCES UNLESS OTHERWISE SPECIFIED: 0 PLC ± 1 PLC ± 2 PLC ± 3 PLC ± 4 PLC ± ANGLES ± FINISH ±					DWN GROSS 30AUG2011 CHK G.BAILEY 30AUG2011 APVD J. CRUZ 30AUG2011		NAME Ocean Side Feed Applicator SIZE CAGE CODE DRAWING NO RESTRICTED TO A1 00779 C=2151154 WEIGHT - SCALE 1:2 SHEET 1 OF 4 REV E		

LOC	DIST	REV	DATE	BY	APPV
A	66				

FEED TYPE MECHANICAL

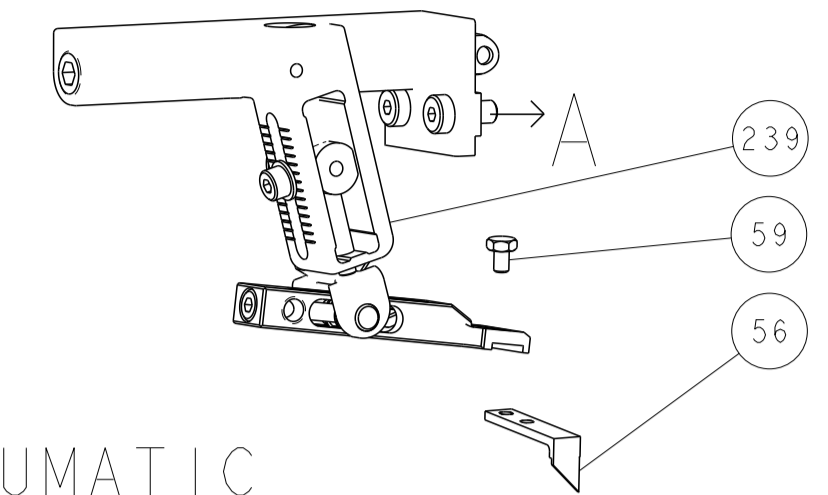

PNEUMATIC

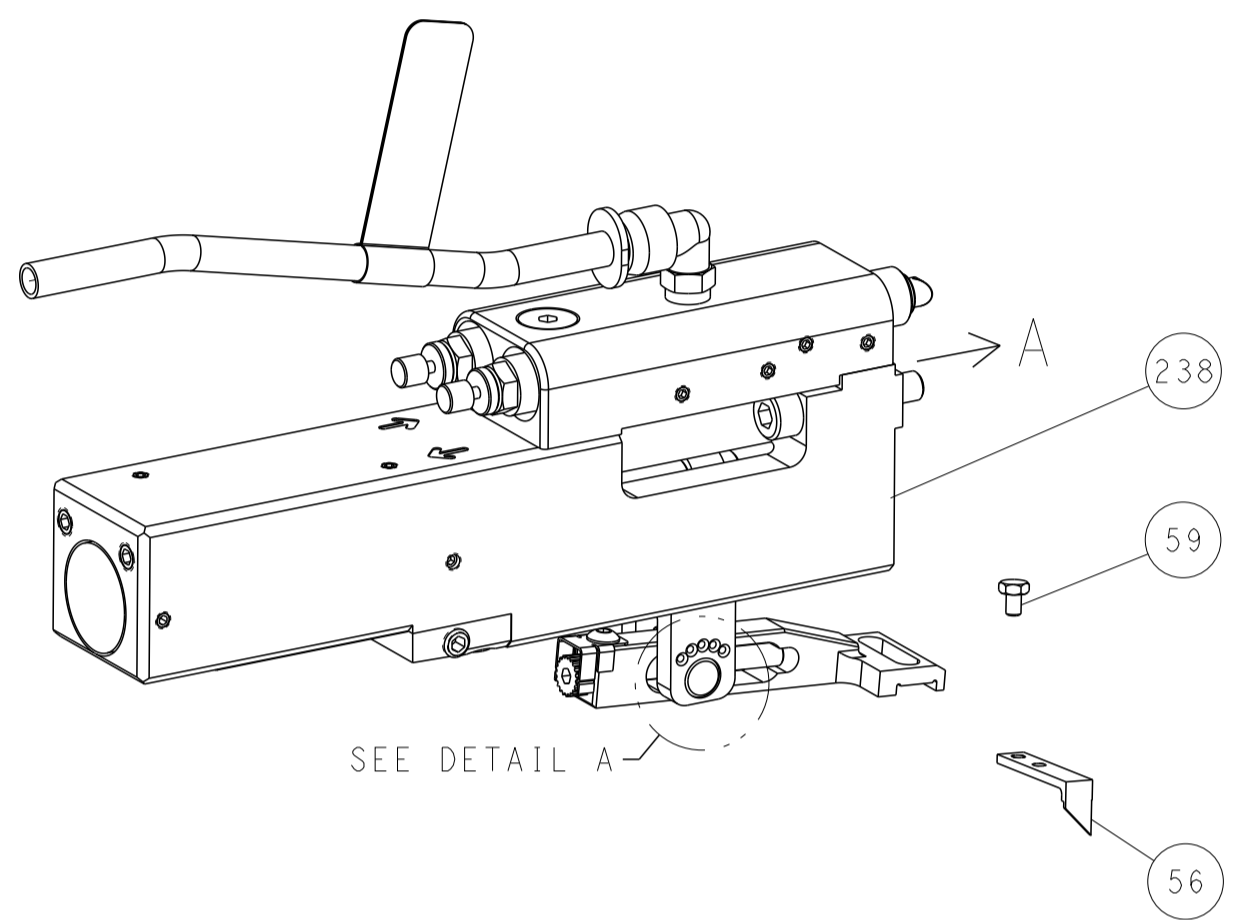

FEED SPRING SETTING POSITION (SHOWN FROM REAR SIDE)



DETAIL A

CAM POSITIONS

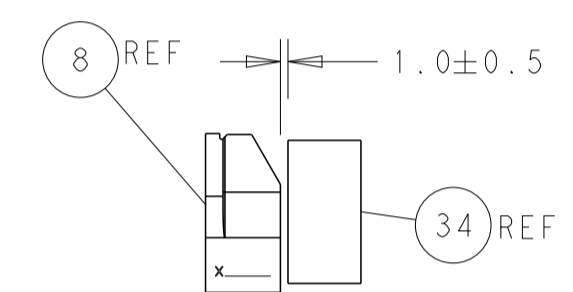
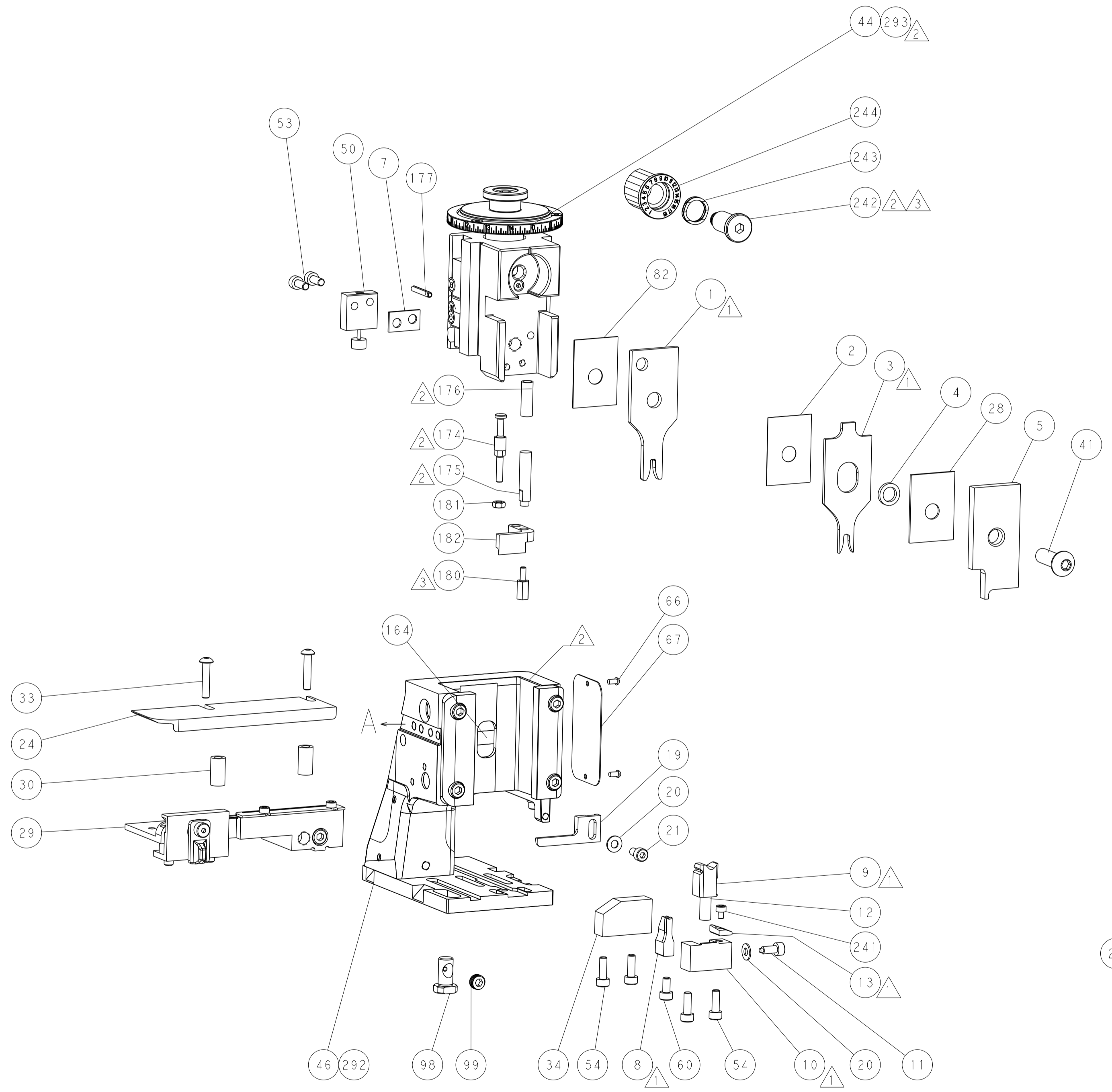
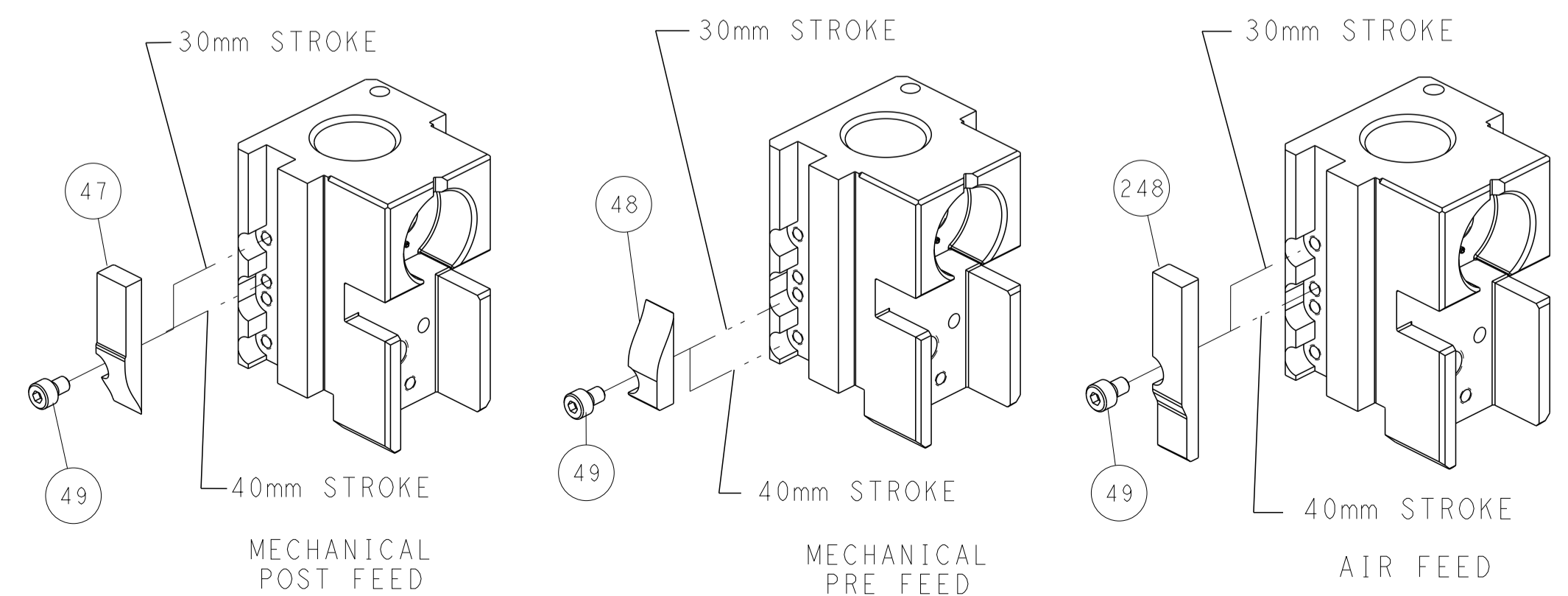

TERMINAL SUPPORT LOCATION

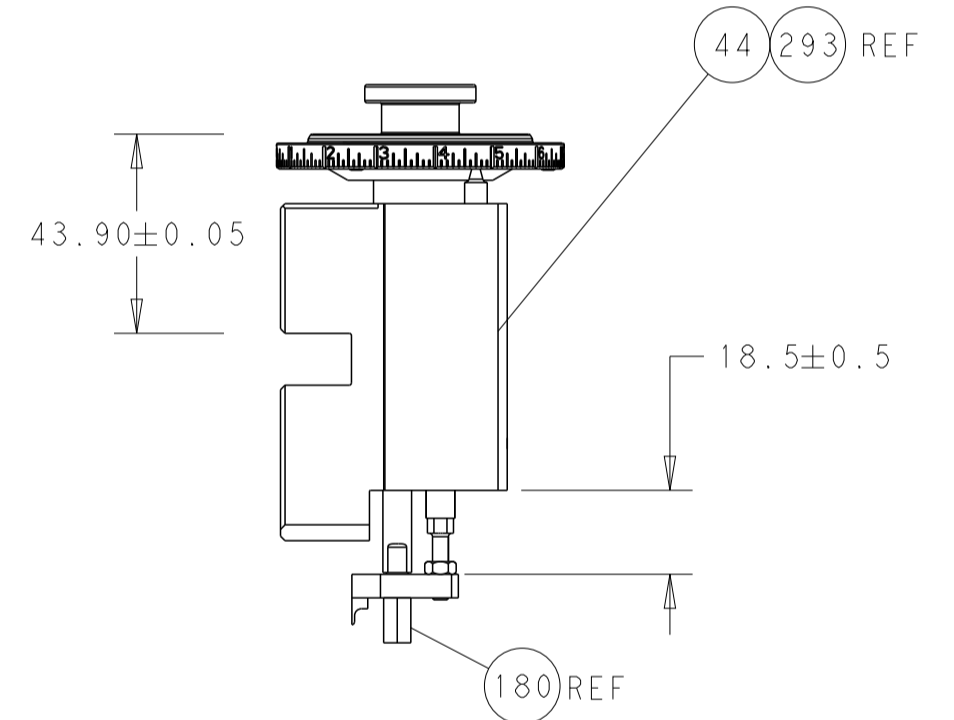

RAM AND HOLDDOWN SET-UP

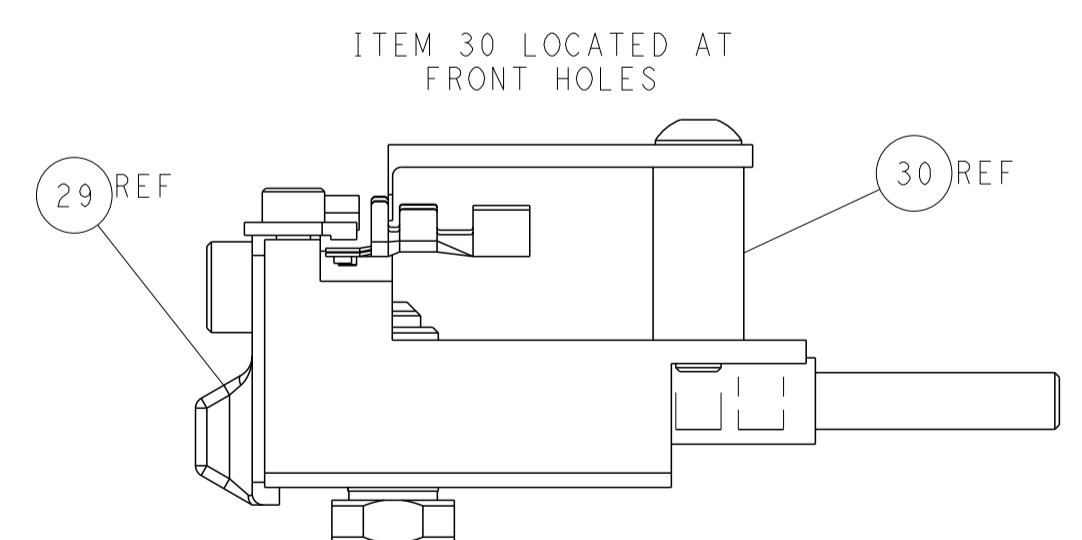

FEED TRACK POSITION GUIDE BY INSULATION BARREL

ATLANTIC VERSION
 Shown on sheets 1 of 4 & 2 of 4
 (Pacific version shown on sheets 3 of 4 & 4 of 4)

DIMENSIONS: mm 		TOLERANCES UNLESS OTHERWISE SPECIFIED: 0 PLC ± 1 PLC ± 2 PLC ± 3 PLC ± 4 PLC ± ANGLES ±		DWN L. GROSS 30AUG2011 CHK G. BAILEY 30AUG2011 APVD J. CRUZ 30AUG2011 PRODUCT SPEC APPLICATION SPEC WEIGHT Customer Accessible Production Drawing		NAME Ocean Side Feed Applicator SIZE CAGE CODE DRAWING NO. RESTRICTED TO A1 00779 C=2151154 SCALE 1:2 SHEET 2 OF 4 REV E	
MATERIAL: FINISH:				TE Connectivity Harrisburg, PA 17105-3608			

8	7	6	5	4	3	2	1
THIS DRAWING IS UNPUBLISHED.		RELEASED FOR PUBLICATION		20			
COPYRIGHT 20 BY TYCO ELECTRONICS CORPORATION. ALL RIGHTS RESERVED.							
PART NUMBER	REVISION	DESCRIPTION	FEED TYPE				
2-2151154-1	E	FINE CRIMP HEIGHT ADJUST	MECHANICAL				
2-2151154-2	E	FINE CRIMP HEIGHT ADJUST	PNEUMATIC				
7-2151154-7	A	CRIMP TOOLING KIT	-				

PACIFIC VERSION TERMINATOR INTERFACE ADAPTER



APPLICATOR DATA		
CRIMP	SIZE	TYPE
WIRE	2.79 mm [.110]	F
INSUL	3.56 mm [.140]	OV
APPLICATOR INSTRUCTIONS 408-35042		

TERMINAL DATA: TE TERMINAL		TE CRIMP SPECIFICATION	
TERMINAL NAME: JUNIOR POWER TIMER CONTACT			
WIRE STRIP LENGTH		INSULATION DIAMETER RANGE	
4.00-4.60 mm [.157-.181 IN]		Ø1.90-2.10 mm [.075-.083 IN]	
TERMINAL APPLICATION SPECIFICATION	114-18050	-	-
TERMINALS APPLIED			
TE TERMINAL	TE TERMINAL	TE TERMINAL	TE TERMINAL
927768-1	927768-9	963884-2	963973-1
927768-2	1-927768-1	965899-1	963973-3
927768-3	2-927768-1	965899-2	1-963973-1
927768-6	963884-1	9-965899-1	2-963973-1
927768-8			

TERMINAL DATA: TE TERMINAL		TE CRIMP SPECIFICATION	
TERMINAL NAME: JUNIOR POWER TIMER CONTACT			
WIRE STRIP LENGTH		INSULATION DIAMETER RANGE	
4.00-4.60 mm [.157-.181 IN]		Ø1.90-2.10 mm [.075-.083 IN]	
TERMINAL APPLICATION SPECIFICATION	114-18050	-	-
TERMINALS APPLIED			
TE TERMINAL	TE TERMINAL	TE TERMINAL	TE TERMINAL
927768-1	927768-9	963884-2	963973-1
927768-2	1-927768-1	965899-1	963973-3
927768-3	2-927768-1	965899-2	1-963973-1
927768-6	963884-1	9-965899-1	2-963973-1
927768-8			

WIRE SIZE	CRIMP HEIGHT mm [INCH]	CRIMP HEIGHT REFERENCE SETTING
2.50mm2	1.77+/-0.05 [.070+/- .002]	8.0
2.00mm2	1.64+/-0.05 [.065+/- .002]	9.5
1.50mm2	1.51+/-0.05 [.059+/- .002]	10.7

WIRE SIZE	CRIMP HEIGHT mm [INCH]	CRIMP HEIGHT REFERENCE SETTING
2X1.00mm2	1.58+/-0.05 [.062+/- .002]	10.1
2X 0.75mm2	1.51+/-0.05 [.059+/- .002]	10.7
0.75 + 0.50mm2	1.40+/-0.05 [.055+/- .002]	11.5

- 1 RECOMMENDED SPARE PARTS
- 2 REFER TO SUPPLIED INSTRUCTION SHEET FOR CLEANING, LUBRICATION AND STORAGE OF APPLICATOR.
- 3 APPLY PART NUMBER 2-23419-6 LOCTITE TO THREADS OF ITEM 242.
- 4 CRIMP HEIGHT REFERENCE SETTING WAS THE SETTING USED WHEN THE APPLICATOR WAS QUALIFIED AT THE FACTORY. ADJUSTMENT MAY BE NECESSARY WHEN RUNNING APPLICATOR IN THE FIELD.
- 5 UNLESS SPECIFIED OTHERWISE TORQUE VALUES SHALL BE USED PER DOCUMENT, 101-35000.
- 6 THIS CRIMP PARAMETER IS PROVIDED TO MEET A CUSTOM AND UNIQUE CUSTOMER REQUIREMENT. IT HAS BEEN EVALUATED AND IS CONDITIONALLY SPECIFIED BY TE CONNECTIVITY. THIS CUSTOMIZED CRIMP PARAMETER IS NOT LISTED AS AN APPROVED APPLICATION WITHIN A TE CONNECTIVITY APPLICATION SPECIFICATION; HOWEVER, IT HAS BEEN VALIDATED ACCORDING TO TE CONNECTIVITY SPECIFICATIONS 109-18079 (TEST GROUP 1) AND 114-18022. **TE CONNECTIVITY EXPRESSLY DISCLAIMS ANY AND ALL WARRANTIES THAT THE PRODUCT WILL PERFORM SIMILARLY TO VALIDATED AND APPROVED APPLICATIONS, AS STATED WITHIN TE CONNECTIVITY APPLICATION SPECIFICATIONS, INCLUDING BUT NOT LIMITED TO IMPLIED WARRANTIES OF MERCHANTABILITY OR FITNESS FOR PARTICULAR PURPOSE.** AS SUCH, IT IS HIGHLY RECOMMENDED THAT THE CUSTOMER PERFORM FURTHER DETAILED EVALUATION TO ASSESS PRODUCT PERFORMANCE IN THE SPECIFIC APPLICATION.

***WARNING**
ON INSTALLATION, SET WIRE DISC TO CRIMP HEIGHT REFERENCE SETTING FOR LARGEST WIRE SIZE. CRIMP HEIGHT REFERENCE SETTINGS GREATER THAN THE VALUE SHOWN MAY CAUSE DAMAGE TO THE CRIMP TOOLING, REFER TO THE INSTRUCTION SHEET FOR PROPER SETUP AND ADJUSTMENTS.

LOC	DIST	REVISIONS					
A	66	P	LTN	DESCRIPTION	DATE	DWN	APVD
		-		SEE SHEET 1	-	-	-

3	-	1	1	2119082-9	CAM, SNAIL, INSULATION ADJUSTMENT	244
	-	1	1	2079764-1	WASHER, WAVE SPRING, CREST-TO-CREST	243
	-	1	1	2119083-1	RETAINER, INSULATION DIAL	242
	-	1	1	7-18023-7	SCR, SKT HD CAP M3 X 4.0	241
	-	-	1	2119580-1	MECHANICAL FEED ASSEMBLY	239
	-	1	-	2844940-1	AIR FEED MODULE	238
	-	REF	REF	994970-2	COUNTER, MAGNETIC	164
	-	1	-	2119641-2	FEED CAM, AIR FEED	151
	-	1	1	2168083-8	SCR, SKT HD CAP, RoHS, M4 X 16	144
	-	4	4	2168083-9	SCR, SKT HD CAP, RoHS, M4 X 20	143
	-	-	1	2119653-2	FEED CAM, POST FEED	142
	-	1	1	1-1803583-0	APPLICATOR BASIC ASSEMBLY, SF	141
	-	1	1	1803516-1	RAM ASSEMBLY, SF PACIFIC	140
	-	1	1	2844908-1	SCREW, LOCKING	99
	-	1	1	2844907-1	POST, LOCKING	98
	-	1	1	455888-5	SPACER, CRIMPER	82
	-	1	1	1803607-3	DOCUMENTATION PACKAGE	71
	-	1	1	2119740-1	TAG, IDENTIFICATION	67
	-	2	2	2168078-1	SCREW, DRIVE, RH, RoHS, 2 x .188	66
	-	1	1	5-18022-5	SCR, HEX HD CAP, M4 X 6.0	59
	-	1	1	1338685-1	PAWL, FEED	56
	-	2	2	1-2168083-0	SCR, SKT HD CAP, RoHS, M4 X 10	53
	-	1	1	1803382-6	HOLD DOWN, SPRING LOADED	50
	-	1	2	18023-9	SCR, SKT HD CAP M4 X 6.0	49
	-	-	1	2119652-1	FEED CAM, PRE FEED	48
	-	1	1	1803602-1	SCR, BHSC, RoHS (M8 X 25)	41
	-	1	1	3-1752356-3	SUPPORT, TERMINAL	34
	-	2	2	2079383-5	SCR, BHSC, RoHS (M4 X 20)	33
	-	2	2	3-2844962-0	SPACER, CYLINDRICAL, STRIP GUIDE	30
	-	1	1	2844992-2	ASSEMBLY, STRIP GUIDE	29
	-	1	1	1-455888-0	SPACER, CRIMPER	28
	-	1	1	1320928-2	STRIP GUIDE	24
	-	1	1	2168083-2	SCR, SKT HD CAP, RoHS, M4 X 8.0	21
	-	2	2	1-18028-2	WASHER, FLAT, REG M4	20
	-	1	1	2119533-1	STRIPPER, SIDE FEED	19
	-	1	1	2119806-1	INSERT, SHEAR	13
	-	1	1	3-22280-3	SPRING, COMPRESSION	12
	-	1	1	1-356885-4	STOP, SHEAR	11
	-	1	1	2119805-1	SHEAR HOLDER, FRONT	10
	-	1	1	1803095-1	FLOATING SHEAR, FRONT	9
	1	1	1	3-1333207-9	ANVIL, COMBINATION .110	8
	-	1	1	6-240641-7	SPACER	7
	-	1	1	2119757-8	DEPRESSOR, SHEAR	5
	-	1	1	2-238011-2	BLOCK, CRIMPER SPACER	4
	1	1	1	1-2119785-1	CRIMPER, INSULATION OVERLAP PREMIUM	3
	-	1	1	455888-2	SPACER, CRIMPER	2
	1	1	1	456408-2	CRIMPER, WIRE PREMIUM	1

PACIFIC VERSION
Shown on sheets 3 of 4 & 4 of 4
(Atlantic version shown on sheets 1 of 4 & 2 of 4)

DIMENSIONS: mm		TOLERANCES UNLESS OTHERWISE SPECIFIED:		DWN GROSS 30AUG2011		TE Connectivity Harrisburg, PA 17105-3608	
0 PLC ±		1 PLC ±		CHK G. BAILEY 30AUG2011		NAME Ocean Side Feed Applicator	
2 PLC ±		3 PLC ±		APVD J. CRUZ 30AUG2011		SIZE CAGE CODE DRAWING NO RESTRICTED TO	
4 PLC ±		ANGLES ±		PRODUCT SPEC		A1 00779 C=2151154	
MATERIAL		FINISH		APPLICATION SPEC		WEIGHT	
						Customer Accessible Production Drawing SCALE 1:2 SHEET 3 OF 4 REV E	

LOC	DIST	REVISIONS					
A	66	P	LTN	DESCRIPTION	DATE	OWN	APVD
		-		SEE SHEET 1			

FEED TYPE MECHANICAL

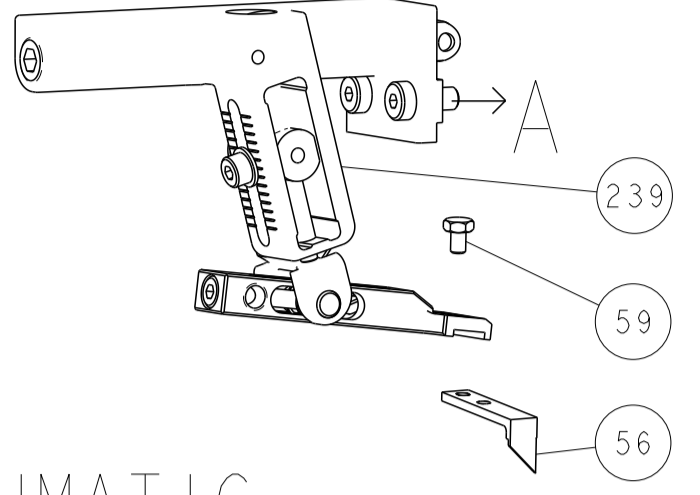

PNEUMATIC

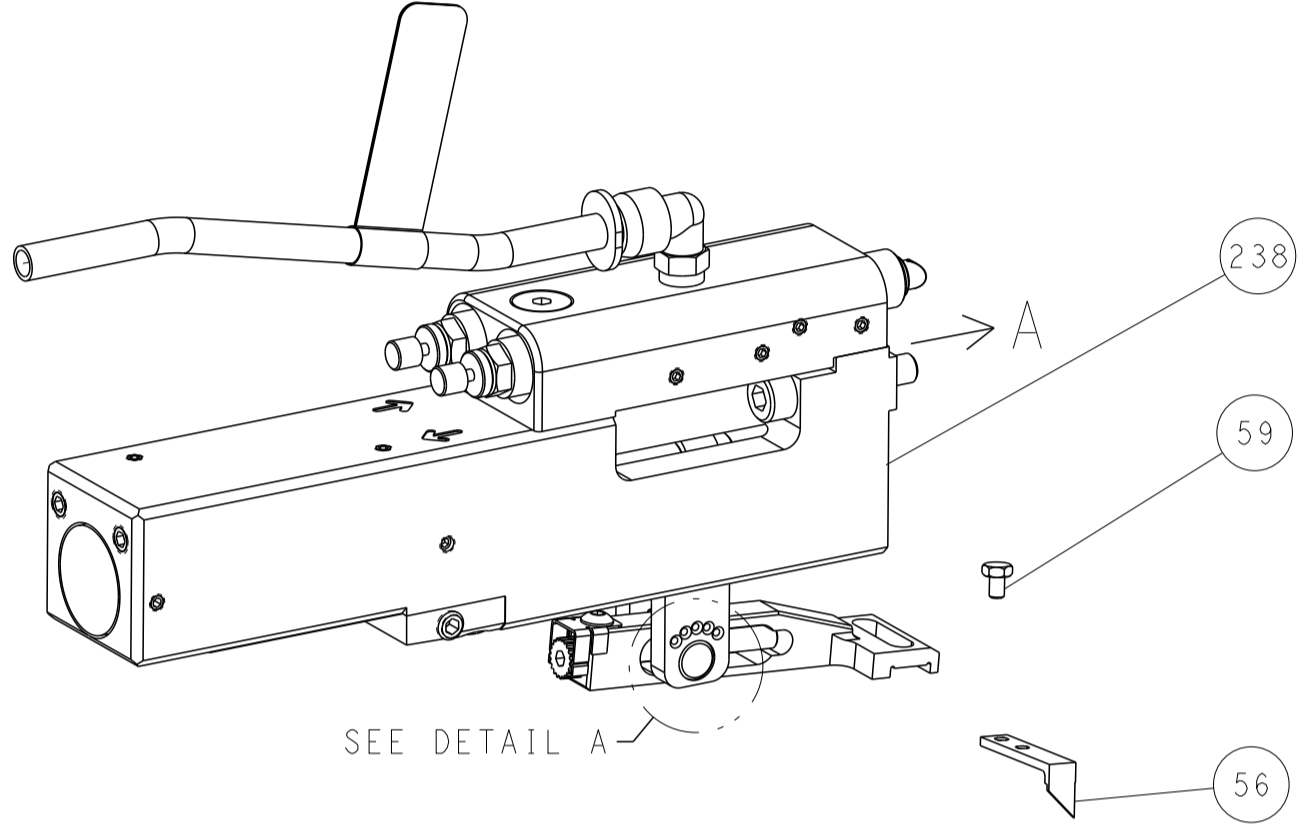

FEED SPRING SETTING POSITION (SHOWN FROM REAR SIDE)

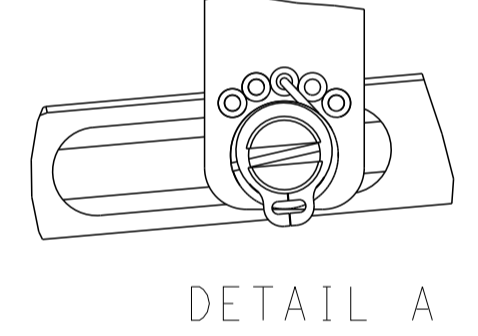

CAM POSITIONS

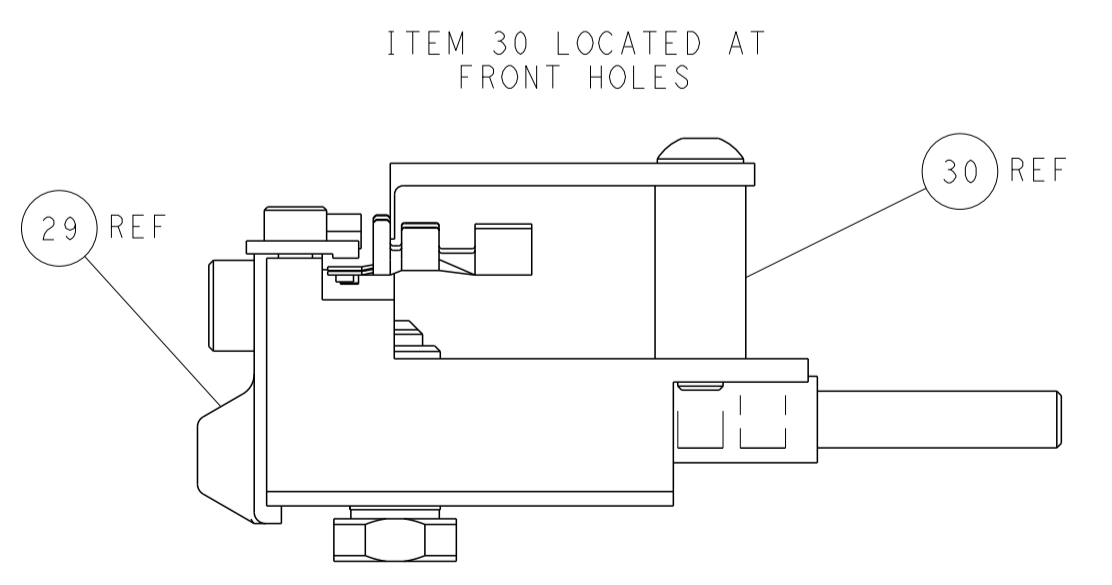
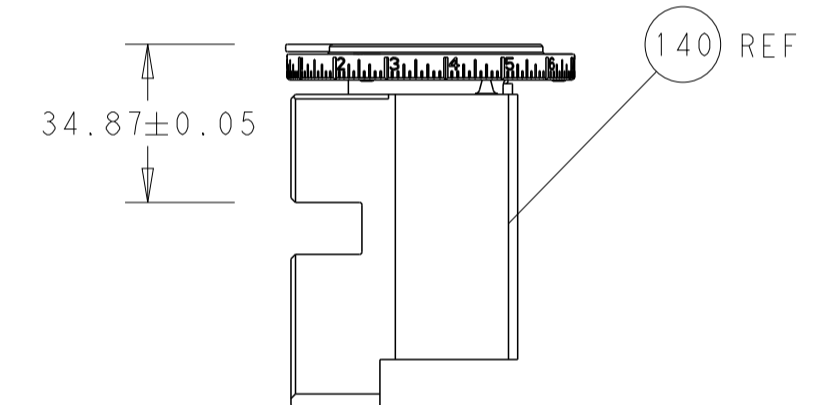
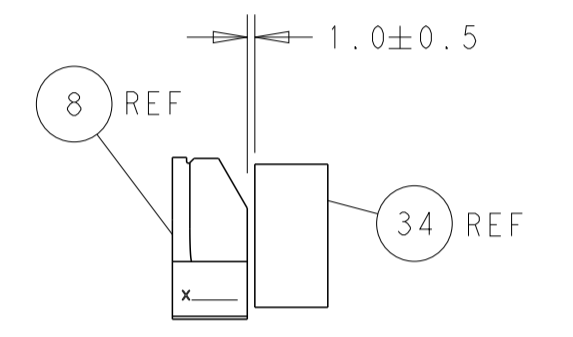
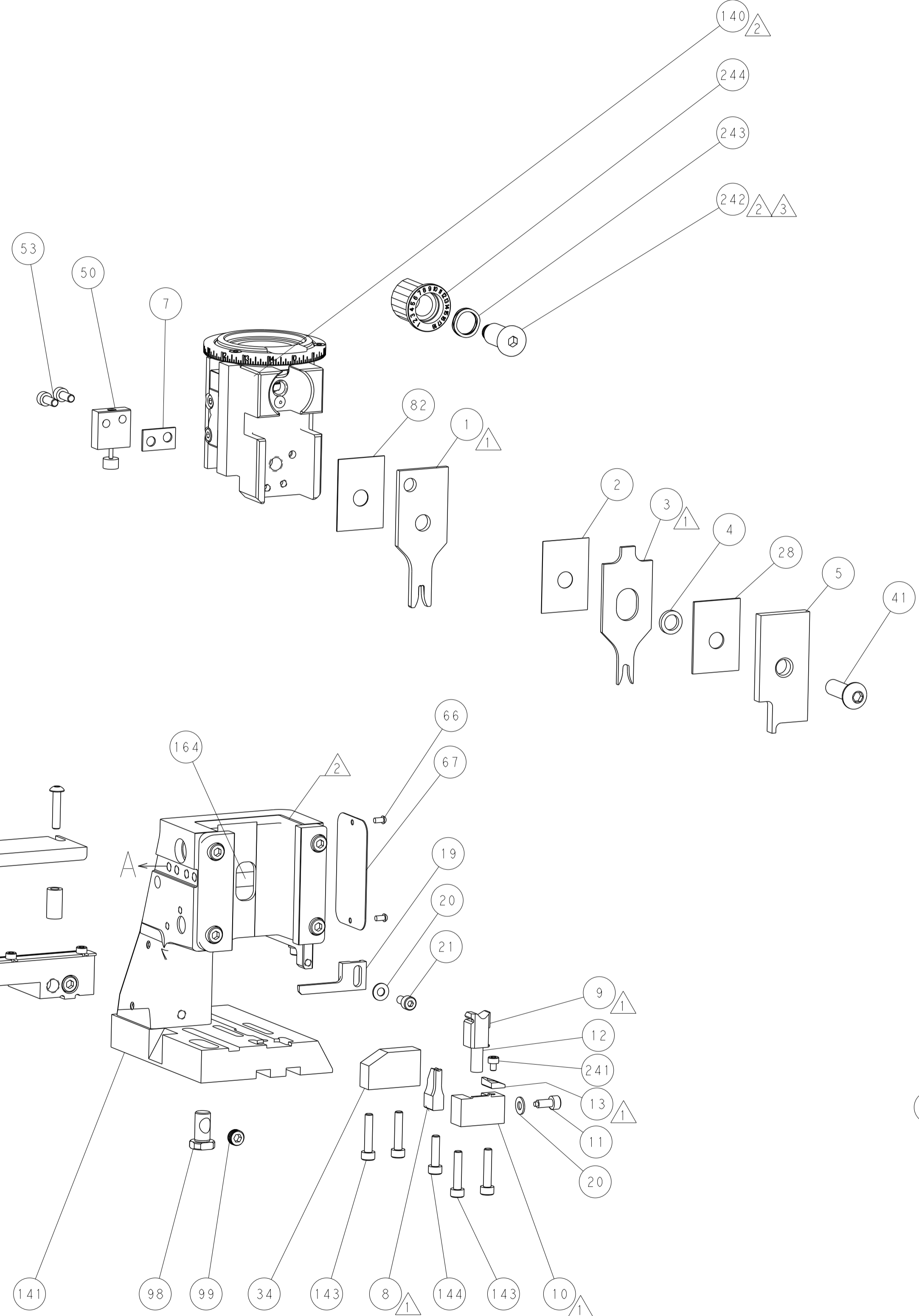
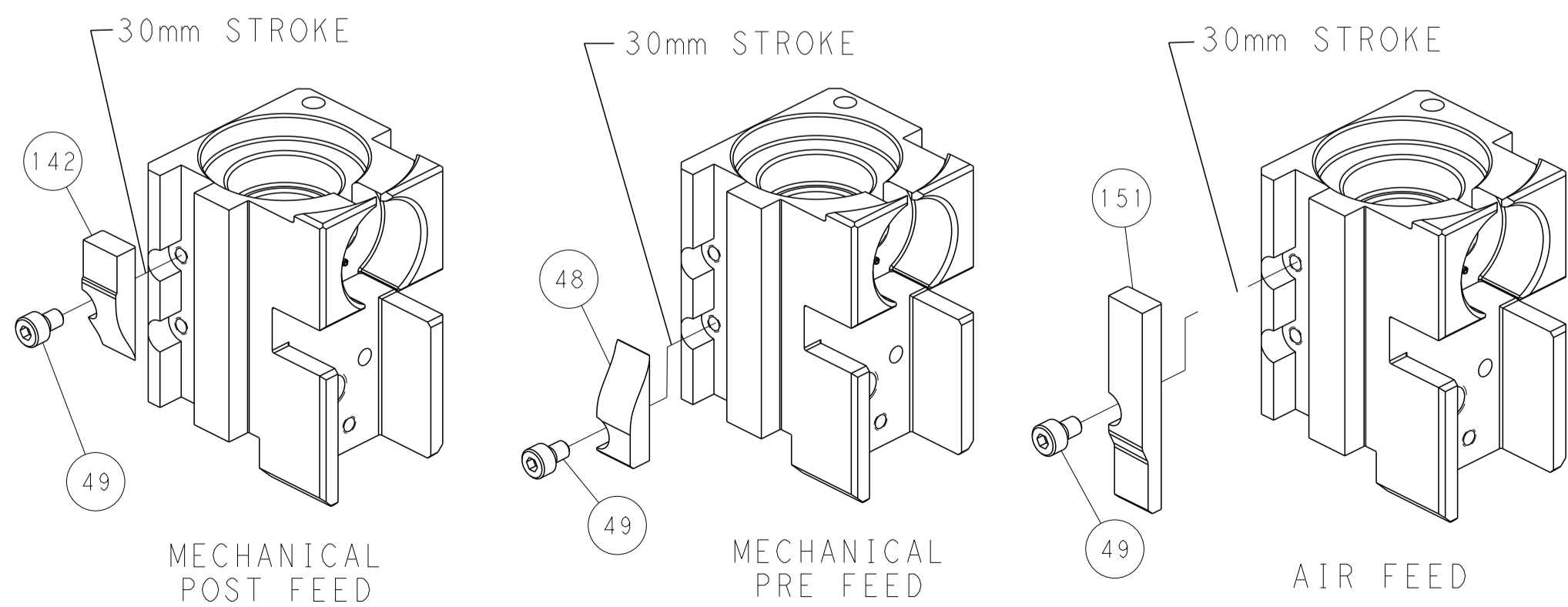

PACIFIC VERSION
 Shown on sheets 3 of 4 & 4 of 4
 (Atlantic version shown on sheets 1 of 4 & 2 of 4)

DIMENSIONS: mm 		TOLERANCES UNLESS OTHERWISE SPECIFIED: 0 PLC ± 1 PLC ± 2 PLC ± 3 PLC ± 4 PLC ± ANGLES ± FINISH ±		DWN L. GROSS 30AUG2011 CHK G. BAILEY 30AUG2011 APVD J. CRUZ 30AUG2011 PRODUCT SPEC APPLICATION SPEC WEIGHT Customer Accessible Production Drawing		NAME Ocean Side Feed Applicator SIZE CAGE CODE DRAWING NO A1 00779 ©=2151154 SCALE 1:2 SHEET 4 OF 4 REV E		RESTRICTED TO -	
-----------------------	--	---	--	---	--	---	--	--------------------	--