

| PART NUMBER | REVISION | DESCRIPTION | FEED TYPE |
|-------------|----------|--|------------|
| 2151033-1 | J | FINE CRIMP HEIGHT ADJUST | MECHANICAL |
| 2151033-2 | J | FINE CRIMP HEIGHT ADJUST | PNEUMATIC |
| 5-2151033-1 | J | SEAL STRIPPER CRIMPER TERMINATING UNIT | MECHANICAL |
| 5-2151033-2 | J | SEAL STRIPPER CRIMPER TERMINATING UNIT | PNEUMATIC |
| 7-2151033-7 | G | CRIMP TOOLING KIT | - |

ATLANTIC VERSION TERMINATOR INTERFACE ADAPTER

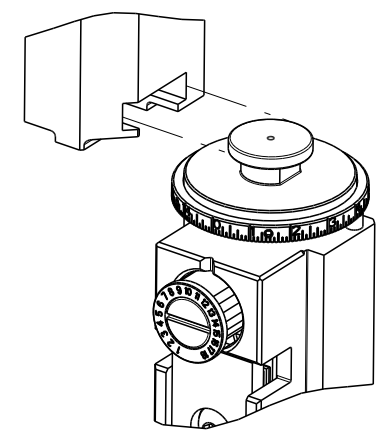

| APPLICATOR DATA | | |
|-----------------|----------------|------|
| CRIMP | SIZE | TYPE |
| WIRE | 1.78 mm [.070] | F |
| INSUL | 2.54 mm [.100] | F |

APPLICATOR INSTRUCTIONS 408-35042

| TERMINAL DATA: TE TERMINAL | | TE CRIMP SPECIFICATION | |
|---|---------------|-----------------------------|--------------|
| TERMINAL NAME: CONTACT, BIFURCATED LEAF | | | |
| WIRE STRIP LENGTH | | INSULATION DIAMETER RANGE | |
| 3.58-4.34 mm [.141-.171 IN] | | Ø 2.54 mm MAX [.100 IN MAX] | |
| TERMINAL APPLICATION SPECIFICATION | (A)114-1015 | | |
| | (B)114-1021 | | |
| TERMINALS APPLIED | | | |
| TE TERMINAL | TE TERMINAL | TE TERMINAL | TE TERMINAL |
| (A) 61668-1 | (A) 1-61668-5 | (B) 342664-2 | (B) 737372-1 |
| (A) 61668-2 | (A) 3-61668-1 | (B) 342664-3 | (B) 737372-2 |
| (A) 61668-4 | (B) 342664-1 | (B) 342664-4 | |

| TERMINAL DATA: TE TERMINAL | | TE CRIMP SPECIFICATION | |
|------------------------------------|----------------|-------------------------------|-----------------|
| TERMINAL NAME: RECEPTACLE, SL-156 | | | |
| WIRE STRIP LENGTH | | INSULATION DIAMETER RANGE | |
| 3.58-4.34 mm [.141-.171 IN] | | Ø 1.09-2.79 mm [.043-.110 IN] | |
| TERMINAL APPLICATION SPECIFICATION | (B)114-1021 | | |
| TERMINALS APPLIED | | | |
| TE TERMINAL | TE TERMINAL | TE TERMINAL | TE TERMINAL |
| (B) 350980-2 | (B) 3-350980-1 | (B) 770476-1 | 7(B) 3-647449-1 |
| (B) 350980-3 | (B) 640252-2 | (B) 770476-2 | |
| (B) 350980-4 | (B) 640252-5 | (B) 770476-3 | |
| (B) 350980-5 | (B) 3-640252-1 | (B) 3-770476-1 | |

| TERMINAL DATA: TE TERMINAL | | TE CRIMP SPECIFICATION | |
|--|----------------|-------------------------------|-------------|
| TERMINAL NAME: LID TYPE RECEPTACLE, SL-156 | | | |
| WIRE STRIP LENGTH | | INSULATION DIAMETER RANGE | |
| 3.58-4.34 mm [.141-.171 IN] | | Ø 1.78-2.84 mm [.070-.112 IN] | |
| TERMINAL APPLICATION SPECIFICATION | (B)114-1021 | | |
| TERMINALS APPLIED | | | |
| TE TERMINAL | TE TERMINAL | TE TERMINAL | TE TERMINAL |
| (B) 4-647406-1 | (B) 3-647406-1 | (B) 647406-2 | |

| WIRE SIZE | CRIMP HEIGHT mm [INCH] | CRIMP HEIGHT REFERENCE SETTING |
|-----------|----------------------------|--------------------------------|
| 18 AWG | 1.30+/-0.05 [.051+/-0.002] | 4.4 |
| 20 AWG | 1.14+/-0.05 [.045+/-0.002] | 6.1 |
| 22 AWG | 1.07+/-0.05 [.042+/-0.002] | 6.7 |
| 24 AWG | 1.02+/-0.05 [.040+/-0.002] | 7.3 |

| WIRE SIZE | CRIMP HEIGHT mm [INCH] | CRIMP HEIGHT REFERENCE SETTING |
|---------------|----------------------------|--------------------------------|
| 18 AWG | 1.30+/-0.05 [.051+/-0.002] | 4.4 |
| 22AWG + 22AWG | 1.22+/-0.05 [.048+/-0.002] | 5.3 |
| 20 AWG | 1.14+/-0.05 [.045+/-0.002] | 6.1 |
| 22 AWG | 1.07+/-0.05 [.042+/-0.002] | 6.7 |
| 24 AWG | 1.02+/-0.05 [.040+/-0.002] | 7.3 |

| WIRE SIZE | CRIMP HEIGHT mm [INCH] | CRIMP HEIGHT REFERENCE SETTING |
|-----------|----------------------------|--------------------------------|
| 18 AWG | 1.30+/-0.05 [.051+/-0.002] | 4.4 |
| 20 AWG | 1.14+/-0.05 [.045+/-0.002] | 6.1 |
| 22 AWG | 1.07+/-0.05 [.042+/-0.002] | 6.7 |
| 24 AWG | 1.02+/-0.05 [.040+/-0.002] | 7.3 |

- 1 RECOMMENDED SPARE PARTS
- 2 REFER TO SUPPLIED INSTRUCTION SHEET FOR CLEANING, LUBRICATION & STORAGE OF APPLICATOR.
- 3 APPLY PART NUMBER 1-23419-5 LOCTITE TO THREADS OF ITEM 180. APPLY PART NUMBER 2-23419-6 LOCTITE TO THREADS OF ITEM 242.
- 4 CRIMP HEIGHT REFERENCE SETTING WAS THE SETTING USED WHEN THE APPLICATOR WAS QUALIFIED AT THE FACTORY. ADJUSTMENT MAY BE NECESSARY WHEN RUNNING APPLICATOR IN THE FIELD.
- 5 TERMINAL LUBRICANT IS RECOMMENDED.
- 6 UNLESS SPECIFIED OTHERWISE TORQUE VALUES SHALL BE USED PER DOCUMENT, 101-35000.
- 7 22AWG + 22AWG WIRE COMBINATION TO ONLY BE USED WITH TERMINAL PN 3-647449-1.

***WARNING**
ON INSTALLATION, SET WIRE DISC TO CRIMP HEIGHT REFERENCE SETTING FOR LARGEST WIRE SIZE. CRIMP HEIGHT REFERENCE SETTINGS GREATER THAN THE VALUE SHOWN MAY CAUSE DAMAGE TO THE CRIMP TOOLING, REFER TO THE INSTRUCTION SHEET FOR PROPER SETUP AND ADJUSTMENTS.

| LOC | DIST | REVISIONS | | | | | |
|-----|------|-----------|-----|---------------|-----------|-----|------|
| A | 66 | P | LTN | DESCRIPTION | DATE | OWN | APVD |
| | | F2 | | ECR-18-014578 | 13SEP2018 | TB | GB |
| | | G | | ECR-19-013206 | 22AUG2019 | JAH | GB |
| | | H | | ECR-20-010922 | 03AUG2020 | FZ | RK |
| | | J | | ECR-24-204563 | 01APR2024 | TB | TE |

| | | | | | | | |
|---|-----|-----|-----|-----|-------------|-------------------------------------|-----|
| - | 1 | 1 | - | - | 1803515-3 | RAM ASSEMBLY, SF ATLANTIC | 293 |
| - | 1 | 1 | - | - | 2-1803583-1 | APPLICATOR BASIC ASSEMBLY, SF | 292 |
| - | 1 | - | 1 | - | 2119641-1 | FEED CAM, AIR FEED | 248 |
| - | 1 | 1 | 1 | 1 | 2119082-4 | CAM, SNAIL, INSULATION ADJUSTMENT | 244 |
| - | 1 | 1 | 1 | 1 | 2079764-1 | WASHER, WAVE SPRING, CREST-TO-CREST | 243 |
| - | 1 | 1 | 1 | 1 | 2119083-1 | RETAINER, INSULATION DIAL | 242 |
| - | 1 | 1 | 1 | 1 | 7-18023-7 | SCR, SKT HD CAP M3 X 4.0 | 241 |
| - | - | 1 | - | 1 | 2119580-1 | MECHANICAL FEED ASSEMBLY | 239 |
| - | 1 | - | 1 | - | 2844940-1 | AIR FEED MODULE | 238 |
| - | 1 | 1 | - | - | 4-1722335-3 | STRIPPER, SIDE FEED | 182 |
| - | 1 | 1 | - | - | 1-5018030-0 | NUT, HEX, REG, RoHS, M3.5 | 181 |
| - | 1 | 1 | - | - | 2-1752354-0 | STANDOFF,HOLD-DOWN | 180 |
| - | 1 | 1 | - | - | 993111-1 | PIN, SLOTTED SPRING 3.0 X 20.0 | 177 |
| - | 1 | 1 | - | - | 5-22280-0 | SPRING, COMPRESSION | 176 |
| - | 1 | 1 | - | - | 1752353-3 | GUIDE PIN,HOLDDOWN | 175 |
| - | 1 | 1 | - | - | 1901680-2 | GUIDE PIN,HOLDDOWN | 174 |
| - | REF | REF | REF | REF | 994970-2 | COUNTER, MAGNETIC | 164 |
| - | 1 | 1 | 1 | 1 | 2119955-1 | ASSY, LUBRICATOR, SIDE FEED | 113 |
| - | 1 | 1 | 1 | 1 | 2844908-1 | SCREW, LOCKING | 99 |
| - | 1 | 1 | 1 | 1 | 2844907-1 | POST, LOCKING | 98 |
| - | 1 | 1 | 1 | 1 | 455888-4 | SPACER, CRIMPER - | 82 |
| - | 1 | 1 | 1 | 1 | 1803607-3 | DOCUMENTATION PACKAGE | 71 |
| - | 1 | 1 | 1 | 1 | 2119791-9 | DEPRESSOR, WIRE | 70 |
| - | 1 | 1 | 1 | 1 | 2119740-1 | TAG,IDENTIFICATION | 67 |
| - | 2 | 2 | 2 | 2 | 2168078-1 | SCREW, DRIVE, RH, RoHS, 2 x .188 | 66 |
| - | 1 | 1 | 1 | 1 | 2168083-2 | SCR, SKT HD CAP, RoHS, M4 X 8.0 | 60 |
| - | 1 | 1 | 1 | 1 | 5-18022-5 | SCR, HEX HD CAP, M4 X 6.0 | 59 |
| - | 1 | 1 | 1 | 1 | 1338685-1 | PAWL, FEED | 56 |
| - | 4 | 4 | 4 | 4 | 2168083-3 | SCR, SKT HD CAP, RoHS, M4 X 12.0 | 54 |
| - | 2 | 2 | 2 | 2 | 2168083-3 | SCR, SKT HD CAP, RoHS, M4 X 12.0 | 53 |
| - | 1 | 1 | 1 | 1 | 5018030-1 | NUT, HEX, REG, RoHS, M3 | 52 |
| - | 1 | 1 | 1 | 1 | 811242-5 | BUMPER, HOLD DOWN | 51 |
| - | 1 | 1 | 1 | 1 | 690753-2 | SPACER, TONKER | 50 |
| - | 1 | 2 | 1 | 2 | 18023-9 | SCR, SKT HD CAP M4 X 6.0 | 49 |
| - | - | 1 | - | 1 | 2119652-1 | FEED CAM, PRE FEED | 48 |
| - | - | 1 | - | 1 | 2119653-1 | FEED CAM, POST FEED | 47 |
| - | - | - | 1 | 1 | 1803583-9 | APPLICATOR BASIC ASSEMBLY, SF | 46 |
| - | - | - | 1 | 1 | 1803515-1 | RAM ASSEMBLY, SF ATLANTIC | 44 |
| - | 1 | 1 | 1 | 1 | 1803602-1 | SCR, BHSC, RoHS (M8 X 25) | 41 |
| - | 1 | 1 | 1 | 1 | 1752356-1 | SUPPORT, TERMINAL | 34 |
| - | 2 | 2 | 2 | 2 | 2079383-5 | SCR, BHSC, RoHS (M4 X 20) | 33 |
| - | 2 | 2 | 2 | 2 | 2-2844962-6 | SPACER, CYLINDRICAL, STRIP GUIDE | 30 |
| - | 1 | 1 | 1 | 1 | 2844992-1 | ASSEMBLY, STRIP GUIDE - | 29 |
| - | 1 | 1 | 1 | 1 | 455888-3 | SPACER, CRIMPER - | 28 |
| - | 1 | 1 | 1 | 1 | 1320928-2 | STRIP GUIDE - | 24 |
| - | - | - | 1 | 1 | 2168083-2 | SCR, SKT HD CAP, RoHS, M4 X 8.0 | 21 |
| - | 1 | 1 | 2 | 2 | 1-18028-2 | WASHER, FLAT, REG M4 | 20 |
| - | - | - | 1 | 1 | 2119533-1 | STRIPPER, SIDE FEED | 19 |
| - | 1 | 1 | 1 | 1 | 2119806-1 | INSERT, SHEAR | 13 |
| - | 1 | 1 | 1 | 1 | 3-22280-3 | SPRING, COMPRESSION | 12 |
| - | 1 | 1 | 1 | 1 | 1-356885-4 | STOP, SHEAR | 11 |
| - | 1 | 1 | 1 | 1 | 2119805-1 | SHEAR HOLDER, FRONT - | 10 |
| - | 1 | 1 | 1 | 1 | 1803095-6 | FLOATING SHEAR, FRONT - | 9 |
| - | 1 | 1 | 1 | 1 | 4-1633139-4 | ANVIL, COMBINATION | 8 |
| - | 1 | 1 | 1 | 1 | 1-240641-7 | SPACER | 7 |
| - | 1 | 1 | 1 | 1 | 2119757-2 | DEPRESSOR, SHEAR | 5 |
| - | 1 | 1 | 1 | 1 | 2-238011-2 | BLOCK, CRIMPER SPACER | 4 |
| - | 1 | 1 | 1 | 1 | 1-1803260-4 | CRIMPER, INSULATION F PREMIUM - | 3 |
| - | 1 | 1 | 1 | 1 | 455888-2 | SPACER, CRIMPER - | 2 |
| - | 1 | 1 | 1 | 1 | 4-456404-4 | CRIMPER, WIRE PREMIUM | 1 |

| DIMENSIONS: | | TOLERANCES UNLESS OTHERWISE SPECIFIED: | | OWN | CHK | APVD | DATE | NAME |
|-------------|---------|--|----------|----------|----------|----------|-----------|--|
| mm | 0 PLC ± | 1 PLC ± | 2 PLC ± | C. MOYER | T. ELBIN | T. ELBIN | 01NOV2011 | TE Connectivity Harrisburg, PA 17105-3608 |
| | 3 PLC ± | 4 PLC ± | ANGLES ± | | | | | |
| MATERIAL | FINISH | | | | | | | |

| SIZE | CAGE CODE | DRAWING NO | RESTRICTED TO |
|------|-----------|------------|---------------|
| A1 | 00779 | C=2151033 | |

Customer Accessible Production Drawing SCALE 1:2 SHEET 1 OF 4 REV J

| LOC | DIST | REVISIONS | | | | | |
|-----|------|-----------|-----|-------------|------|-----|------|
| A | 66 | P | LTN | DESCRIPTION | DATE | DWN | APVD |
| | | - | | SEE SHEET 1 | | | |

FEED TYPE MECHANICAL

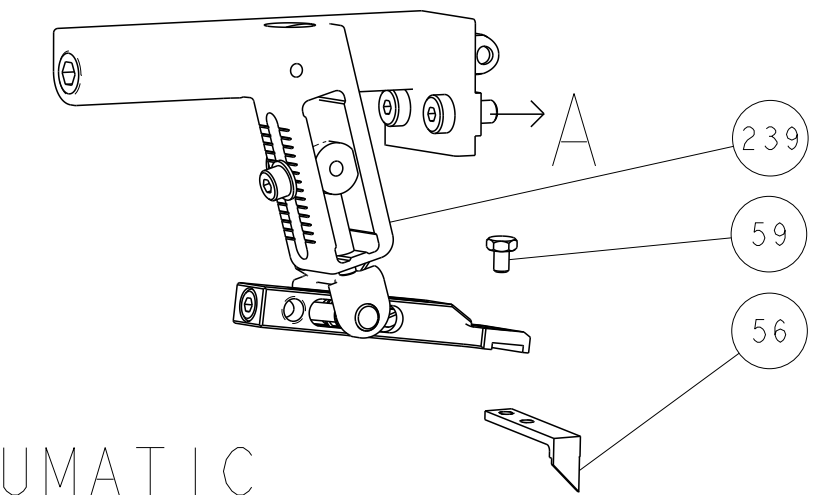

PNEUMATIC

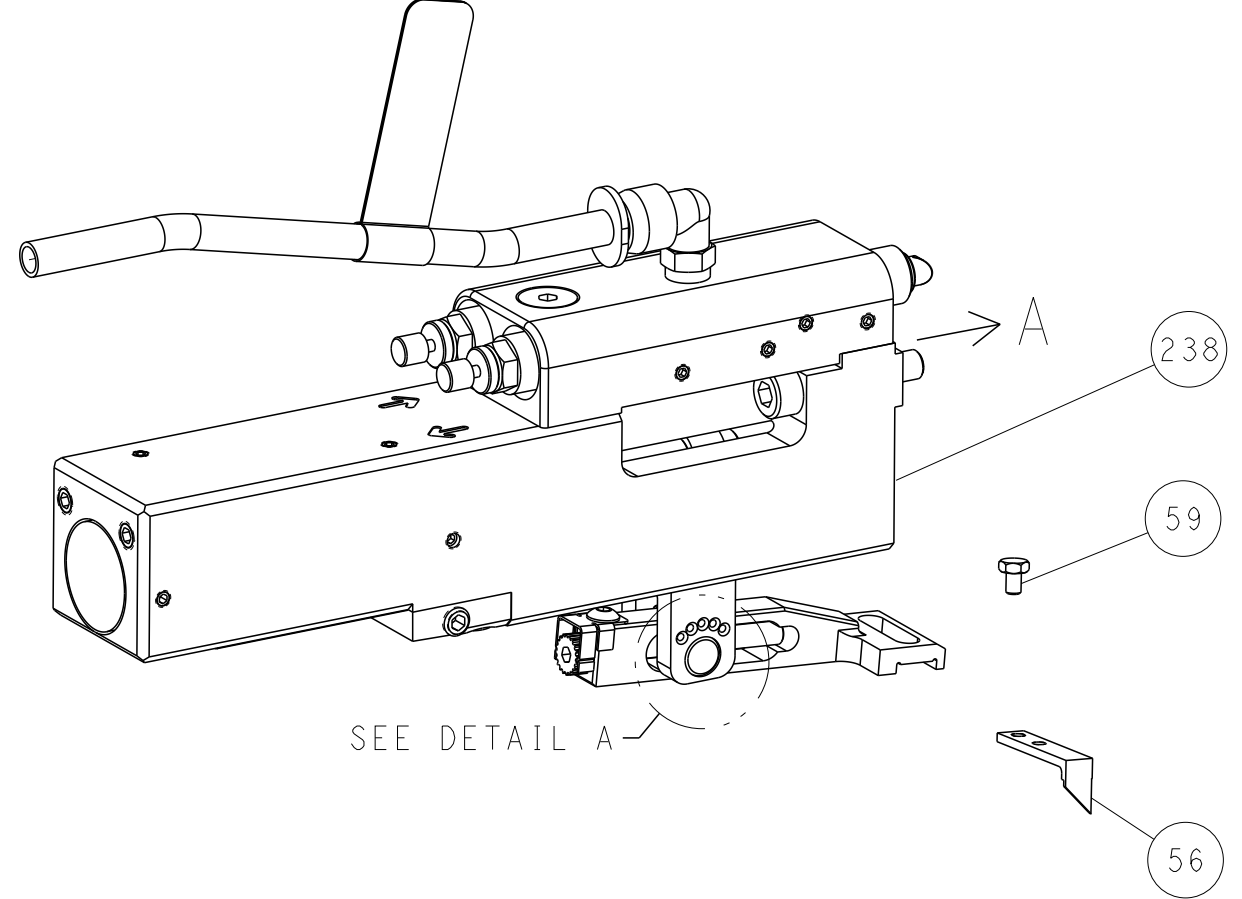

FEED SPRING SETTING POSITION (SHOWN FROM REAR SIDE)



CAM POSITIONS

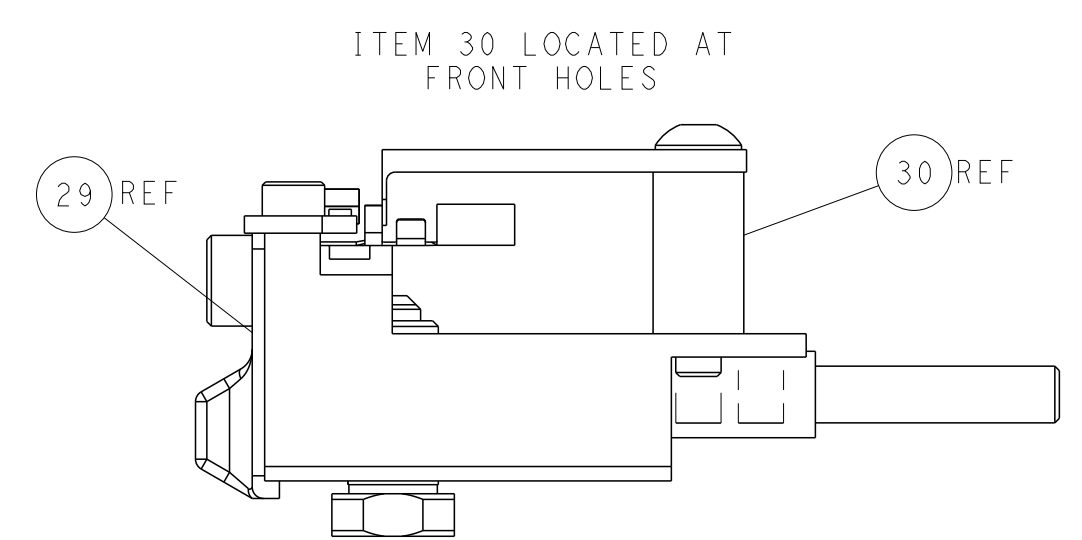
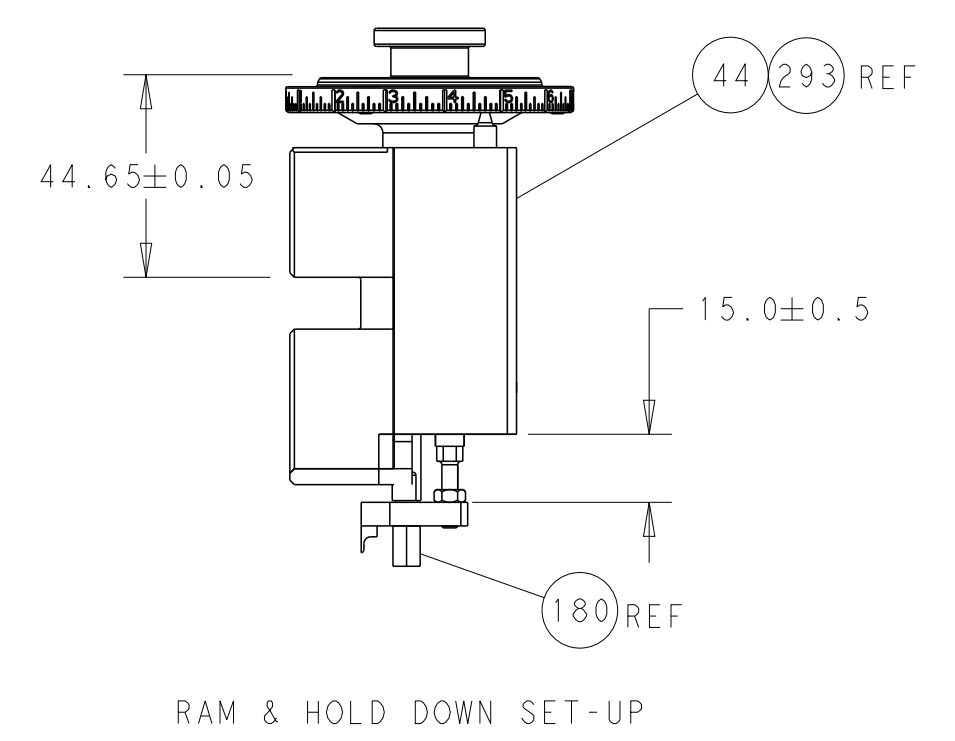
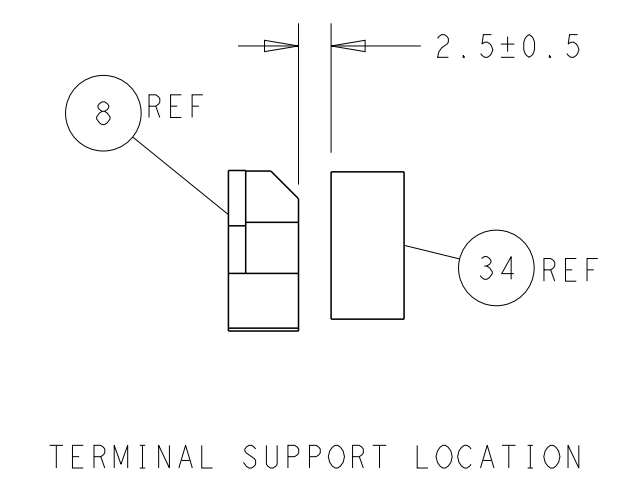
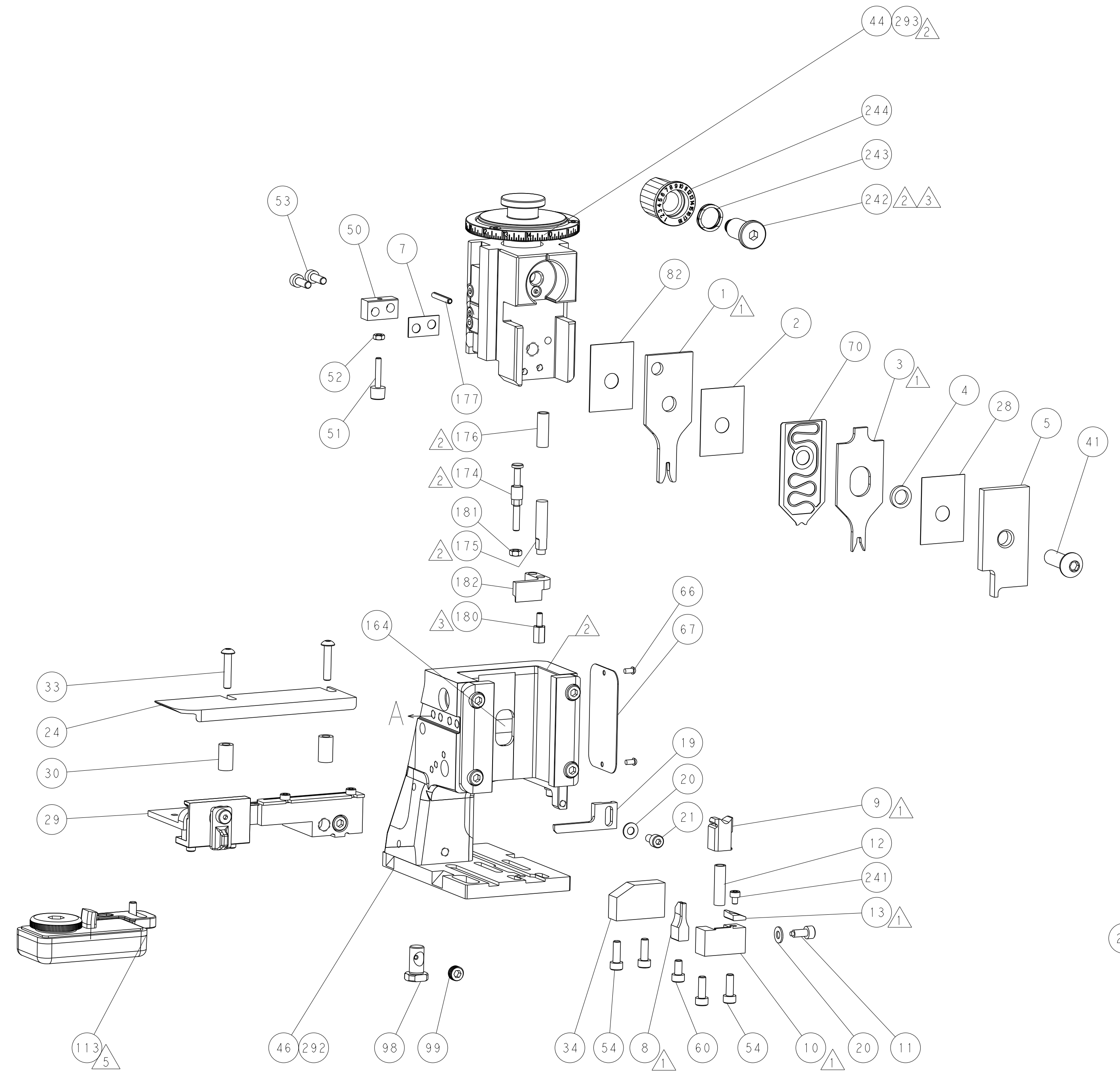
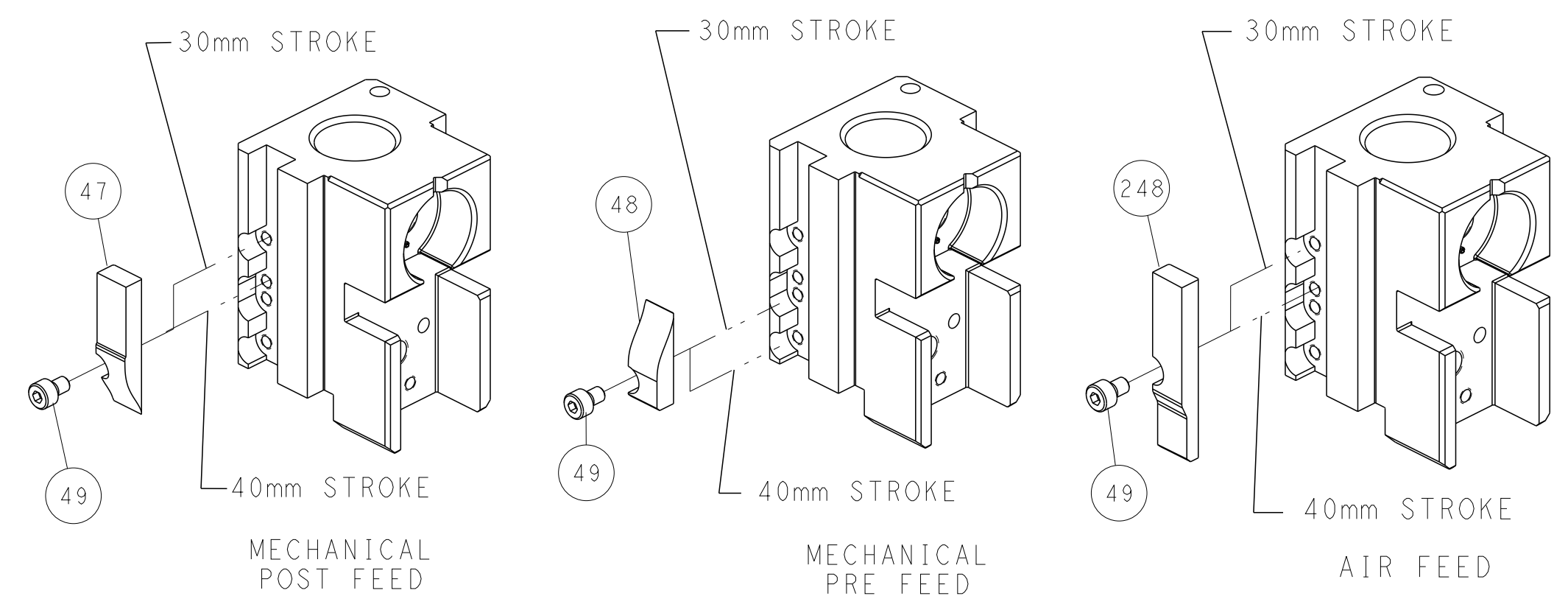

| DIMENSIONS: | | TOLERANCES UNLESS OTHERWISE SPECIFIED: | | DWN | | TE Connectivity | |
|--|--------|--|--|---------------|-----------|----------------------------|--------------|
| mm | 0 PLC | ± | | C. MOYER | 01NOV2011 | Harrisburg, PA 17105-3608 | |
| | 1 PLC | ± | | CHK T. ELBIN | 01NOV2011 | NAME | |
| | 2 PLC | ± | | APVD T. ELBIN | 01NOV2011 | Ocean Side Feed Applicator | |
| | 3 PLC | ± | | | | APPLICATION SPEC | |
| | 4 PLC | ± | | | | SIZE CAGE CODE DRAWING NO | |
| | ANGLES | ± | | | | RESTRICTED TO | |
| MATERIAL | FINISH | | | WEIGHT | | A 00779 C=2151033 | |
| Customer Accessible Production Drawing | | | | SCALE | 1:2 | SHEET | 2 of 4 REV J |