

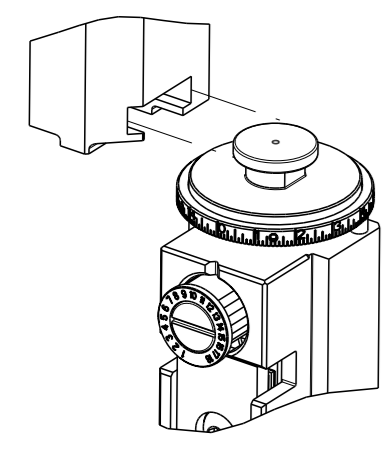

ATLANTIC VERSION TERMINATOR INTERFACE ADAPTER	PART NUMBER	REVISION	DESCRIPTION	FEED TYPE	APPLICATOR STYLE CONVERSION CHART						
					CONVERT TO	PART NUMBERS REQUIRED					
	2150789-1	A	FINE CRIMP HEIGHT ADJUST	MECHANICAL	PNEUMATIC FEED	2119950-1	2119792-1	-	2119641-1	-	2063440-1
					SERVO LATCH PLATE	2119951-1	1901697-1	8-2150789-5	-	-	2168400-7 (QUANTITY 2)
					SMART APPLICATOR	2161326-1	-	8-2150789-4	-	-	-
	2150789-2	A	FINE CRIMP HEIGHT ADJUST	PNEUMATIC	MECHANICAL FEED	2119949-1	2063961-1	5-18022-5	2119653-1	-	-
					SERVO LATCH PLATE	2119951-1	1901697-1	8-2150789-5	-	-	2168400-7 (QUANTITY 2)
					SMART APPLICATOR	2161326-1	-	8-2150789-4	-	-	-
	2150789-5	A	FINE CRIMP HEIGHT ADJUST	SERVO LATCH PLATE <sup>4</sup>	MECHANICAL FEED	2119949-1	2063961-1	5-18022-5	2119653-1	-	-
					PNEUMATIC FEED	2119950-1	2119792-1	-	2119641-1	-	2063440-1
	2150789-6	A	NON-CRIMP HEIGHT ADJUST	SERVO LATCH PLATE <sup>4</sup>	-	-	-	-	-	-	-
					-	-	-	-	-	-	-
	2150789-7	A	FINE CRIMP HEIGHT ADJUST	NONE	-	-	-	-	-	-	-
	7-2150789-7	A	CRIMP TOOLING KIT	-	-	-	-	-	-	-	-

APPLICATOR DATA		
CRIMP	SIZE	TYPE
WIRE	2.50 mm [.098]	F
INSUL	3.80 mm [.150]	F
APPL INSTRUCTIONS 408-10390 		

TERMINAL DATA: STOCKO TERMINAL STOCKO CRIMP SPECIFICATION	
TERMINAL NAME: RSB 8030 RECEPTACLE	
WIRE STRIP LENGTH 4.80-5.80 mm [.189-.228 IN]	INSULATION DIAMETER RANGE Ø1.90-3.30 mm [.075-.130 IN]
TERMINAL APPLICATION SPECIFICATION RSB 8030 F 6.3-1 Rev 29/10/2010	
TERMINALS APPLIED <sup>3</sup>	
TE TERMINAL	STOCKO TERMINAL
2303738-1	RSB 8030 F 6.3-1

WIRE SIZE	CRIMP HEIGHT mm [INCH]	CRIMP HEIGHT REFERENCE SETTING
1.50mm2	1.85 +/- 0.02 [.073 +/- .001]	7.2
1.00mm2	1.68 +/- 0.02 [.066 +/- .001]	9.0
0.75mm2	1.58 +/- 0.02 [.062 +/- .001]	10.2
0.50mm2	1.50 +/- 0.02 [.059 +/- .001]	11.1

- <sup>1</sup> RECOMMENDED SPARE PARTS
- <sup>2</sup> GREASE BEARING SURFACES LIGHTLY
- 3. LUBRICATE DAILY PER THE APPLICATOR INSTRUCTION SHEET SUPPLIED WITH THE APPLICATOR.
- <sup>4</sup> APPLICATOR SPECIFIC DATA TO BE ENTERED INTO BLANK MEMORY CHIP AT ASSEMBLY. SEE BELOW FOR PART NUMBER:  
 MECHANICAL FEED WITH "SMART APPLICATOR" CONVERSION: 8-2150789-4  
 PNEUMATIC FEED WITH "SMART APPLICATOR" CONVERSION: 8-2150789-4  
 SERVO FEED WITH "FINE CRIMP HEIGHT ADJUST": 8-2150789-5  
 SERVO FEED WITH "NON-CRIMP HEIGHT ADJUST": 8-2150789-6
- 5. ADJUSTMENT OF THE STRIPPER MAY BE REQUIRED WHEN MOVING THE APPLICATOR BETWEEN BENCH AND LEADMAKER APPLICATIONS.
- <sup>6</sup> APPLY PART NUMBER 1-23419-5 LOCTITE TO THREADS OF ITEMS 62 & 180. APPLY PART NUMBER 2-23419-6 LOCTITE TO THREADS OF ITEM 242. FOR -6 ONLY APPLY PART NUMBER 1-23419-5 LOCTITE TO THREADS OF ITEMS 37 & 180.
- <sup>7</sup> GREASE THREADS, GROOVE AND O-RING ON ITEMS 35 & 252.
- <sup>8</sup> MAGNET, ITEM 166 MUST BE ORIENTED CORRECTLY IN ORDER TO PROPERLY ACTUATE THE COUNTER.
- <sup>9</sup> CRIMP HEIGHT REFERENCE SETTING WAS THE SETTING USED WHEN THE APPLICATOR WAS QUALIFIED AT THE FACTORY. ADJUSTMENT MAY BE NECESSARY WHEN RUNNING APPLICATOR IN THE FIELD.
- <sup>10</sup> SPARE FEED CAM STORAGE LOCATION REFER TO INSTRUCTION SHEET FOR ADDITIONAL INFORMATION.
- <sup>11</sup> THE RECOMMENDED SET-UP FOR END FEED APPLICATORS IS POST-FEED WITH ITEM 2119653-1. THE APPLICATOR CAN BE CONFIGURED FOR PRE-FEED WITH ITEM 2119652-1 BUT MAY ENCOUNTER PROBLEMS WITH SOME APPLICATIONS. FEED ISSUES OR TERMINAL JAMMING MAY OCCUR IN THE PRE-FEED CONFIGURATION.
- <sup>12</sup> WHEN ASSEMBLING -6 NON-CRIMP HEIGHT ADJUST APPLICATOR USE SHIM PACK 2119957-2 TO ALIGN APPLICATOR'S MAXIMUM WIRE CRIMP HEIGHT AT NORMAL TERMINATOR SHUT HEIGHT.
- <sup>13</sup> TERMINAL LUBRICANT IS RECOMMENDED.

**\*WARNING**  
 ON INSTALLATION, SET WIRE DISC, ITEM 40 TO LARGEST WIRE SIZE SETTING. USE OF SETTINGS BELOW MINIMUM REQUIRED CRIMP HEIGHT SETTING WILL CAUSE DAMAGE TO CRIMP TOOLING.

-77	-7	-6	-5	-2	-1	PART NO	DESCRIPTION	ITEM NO
-	-	1	-	-	-	2119957-2	APPLICATOR SHIM PACK	260
-	1	-	1	1	1	8-21084-0	O-RING, .676 ID, .070 DIA. MAT.	252
-	-	-	-	1	-	2119640-1	PUSH ROD, AIR FEED	250
-	-	-	-	1	-	1803259-1	BUSHING, FLANGED	249
-	-	-	-	1	-	2119641-1	FEED CAM, AIR FEED	248
-	1	-	1	1	1	2119798-1	DETENT PIN	247
-	1	-	1	1	1	1-22279-3	SPRING, COMPRESSION	246
-	-	1	-	-	-	2119759-1	RAM, AMP STYLE, END FEED, NON-ADJUST	245
-	1	1	1	1	1	2119082-4	CAM, SWAIL, INSULATION ADJUSTMENT	244

**ATLANTIC VERSION**  
 Shown on sheets 1 of 4 & 2 of 4  
 (Pacific version shown on sheets 3 of 4 & 4 of 4)

SET UP GAUGE	LOC	DIST	REVISIONS			
2119599-2	A	66	REV	DATE	BY	APPV
			A	RELEASED	26APR2017	TE

-	1	1	1	1	1	2079764-1	WASHER, WAVE SPRING, CREST-TO-CREST	243
-	1	1	1	1	1	2119083-1	RETAINER, INSULATION DIAL	242
-	-	2	2	-	-	2168400-7	SHCS, LOW HEAD, RoHS, M5 X 10	240
-	-	-	-	-	1	2119580-1	MECHANICAL FEED ASSEMBLY	239
-	-	-	-	1	-	2063440-1	AIR FEED MODULE	238
-	-	1	1	-	-	2119740-2	TAG, IDENTIFICATION	213
-	-	REFREF	-	-	-	1901697-1	FEED FINGER ASSEMBLY, EF	183
-	1	1	1	1	1	1976055-8	STANDOFF, HOLD-DOWN	180
-	1	1	1	1	1	6-993111-6	PIN, SLOTTED SPRING 3.0 X 14.0	177
-	1	1	1	1	1	8-22280-7	SPRING, COMPRESSION	176
-	1	1	1	1	1	1752353-2	GUIDE PIN, HOLDDOWN	175
-	1	1	1	1	1	1901680-2	GUIDE PIN, HOLDDOWN	174
-	-	-	-	2	-	21045-3	RING, RETAIN, EXTERN, 3/16 CRESCENT	172
-	1	1	1	1	1	994969-1	MAGNET, RARE EARTH HIGH ENERGY	166
-	REFREF	REFREF	REFREF	REFREF	REFREF	994970-2	COUNTER, MAGNETIC	164
-	-	-	-	1	-	240638-1	SPRING, FEED FINGER	163
-	-	-	-	1	-	3-23627-7	PIN, RETAIN, GRVD, 3/16 X .854	137
-	-	REFREF	-	-	-	SEE NOTE 4	MEMORY CHIP, PROGRAMMED	135
-	-	1	1	-	-	1633743-1	SERVO FEED LATCH ASM	133
-	1	1	1	1	1	2119955-2	ASSY, LUBRICATOR, END FEED	84
-	1	1	1	1	1	455888-7	SPACER, CRIMPER	82
-	1	1	1	1	1	2119956-2	DOCUMENTATION PACKAGE	71
-	2	2	2	2	2	2-18032-2	SCR, SET, FLT POINT M3 X 10.0	70
-	1	-	-	1	1	2119740-1	TAG, IDENTIFICATION	67
-	2	2	2	2	2	2168078-1	SCREW, DRIVE, RH, RoHS, 2 x .188	66
-	1	1	1	1	1	1901681-5	HOLDDOWN, TERMINAL	65
-	2	2	2	2	2	2168400-8	SHCS, LOW HEAD, RoHS, M4 X 16	64
-	1	-	1	1	1	2119793-1	LIMITER, ADJUSTMENT BOLT	63
-	3	-	3	3	3	992763-5	SCR, SET, SOC, CONE POINT, M3 X 4.0	62
-	1	1	1	1	1	2079383-4	SCR, BHSC, RoHS (M4 X 8)	60
-	-	-	-	-	1	5-18022-5	SCR, HEX HD CAP, M4 X 6.0	59
-	-	-	-	-	1	2063961-1	FEED FINGER	58
-	3	3	3	3	3	2168400-4	SHCS, LOW HEAD, RoHS, M4 X 8	57
-	2	2	2	2	2	1-2168083-0	SCR, SKT HD CAP, RoHS, M4 X 10	56
-	2	2	2	2	2	5018030-1	NUT, HEX, REG, RoHS, M3	54
-	2	2	2	2	2	986965-8	NUT, LOCK, HEX, TORQUE (M4)	53
-	1	1	1	1	1	1-5018030-0	NUT, HEX, REG, RoHS, M3.5	52
-	-	-	-	1	-	2119792-1	PAWL, EF, AIR	51
-	-	-	-	1	2	18023-9	SCR, SKT HD CAP M4 X 6.0	49
-	-	-	-	-	1	2119652-1	FEED CAM, PRE FEED	48
-	-	-	-	-	1	2119653-1	FEED CAM, POST FEED	47
-	1	1	1	1	1	2119655-5	APPLICATOR BASIC ASSEMBLY, EF	46
-	1	-	1	1	1	2119369-1	RAM, AMP STYLE, END FEED	44
-	1	1	1	1	1	2079383-7	SCR, BHSC, RoHS (M8 X 25)	41
-	1	-	1	1	1	2119645-1	DISC, NUMBERED FA WIRE ADJUSTMENT	40
-	1	-	1	1	1	2119957-1	APPLICATOR SHIM PACK	39
-	1	1	1	1	1	2119644-2	RAM WASHER, PRECISION	38
-	1	1	1	1	1	2119085-1	FA HEAD, ATLANTIC STYLE	37
-	1	-	1	1	1	2119092-1	BOLT, ADJUSTMENT	35
-	7	7	7	7	7	1-18028-2	WASHER, FLAT, REG M4	33
-	2	2	2	2	2	2168083-9	SCR, SKT HD CAP, RoHS, M4 X 20	31
-	2	2	2	2	2	2168083-2	SCR, SKT HD CAP, RoHS, M4 X 8.0	29
-	1	1	1	1	1	240639-1	STRIPPER (MACHINING)	27
-	2	2	2	2	2	1-2168083-5	SCR, SKT HD CAP, RoHS, M4 X 30	25
-	1	1	1	1	1	1-1752371-6	PLATE, STRIP GUIDE	24
-	1	1	1	1	1	240825-1	PLATE, STRIP HOLD DOWN	23
-	2	2	2	2	2	2-22281-3	SPRING, COMPRESSION	22
-	1	1	1	1	1	1803292-4	DRAG	20
-	2	2	2	2	2	1901259-4	GUIDE, LOWER STRIP	18
-	4	4	4	4	4	1-2079383-1	SCR, BHSC, RoHS (M6 X 12)	17
-	1	1	1	1	1	1-240641-6	SPACER	16
-	1	1	1	1	1	1752360-1	SPACER, HOLD-DOWN	13
-	1	1	1	1	1	240644-5	PLATE, REAR SHEAR	11
-	-	-	-	-	-	-	-	10
-	1	1	1	1	1	5-690495-2	PLATE, FRONT SHEAR	9
-	1	1	1	1	1	2-1803257-7	ANVIL, COMBINATION, END FEED	8
-	1	1	1	1	1	1-2217206-0	BLADE, SLUG	7
-	-	-	-	-	-	-	-	6
-	1	1	1	1	1	1338708-1	SPACER, SLUG BLADE	5
-	1	1	1	1	1	4-238009-1	BLOCK, FL CRIMPER SPACER	4
-	1	1	1	1	1	7-1803187-1	CRIMPER, INSULATION F	3
-	1	1	1	1	1	455888-5	SPACER, CRIMPER	2
-	1	1	1	1	1	1-1803188-6	CRIMPER, WIRE	1

DIMENSIONS:		TOLERANCES UNLESS OTHERWISE SPECIFIED:		OWN	CHK	APPV	DATE	NAME	SCALE	SHEET	OF	REV
mm	0 PLC ±	1 PLC ±	2 PLC ±	M	HERR	T	21MAR2017	TE Connectivity	1:1	1	4	A
	3 PLC ±	4 PLC ±	ANGLES FINISH		ELBIN		21MAR2017	Harrisburg, PA 17105-3608				
MATERIAL								Ocean End Feed Applicator				
								Customer Accessible Production Drawing				

LOC		DIST		REVISIONS			
A	66	P	LYR	DESCRIPTION	DATE	OWN	APVD
		-		SEE SHEET 1			

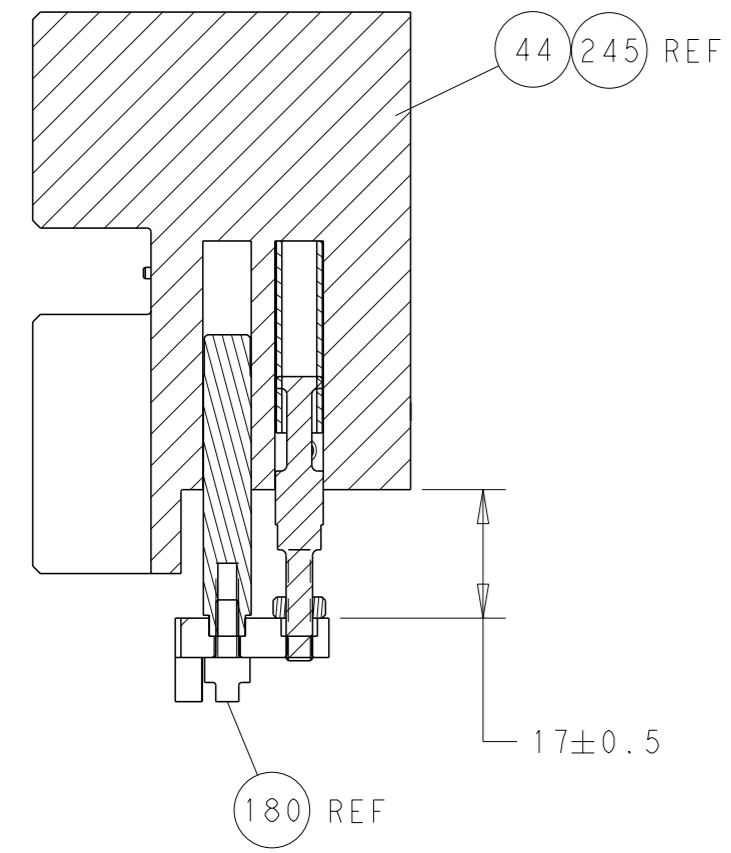

HOLDDOWN SET-UP

FEED TYPE  
MECHANICAL

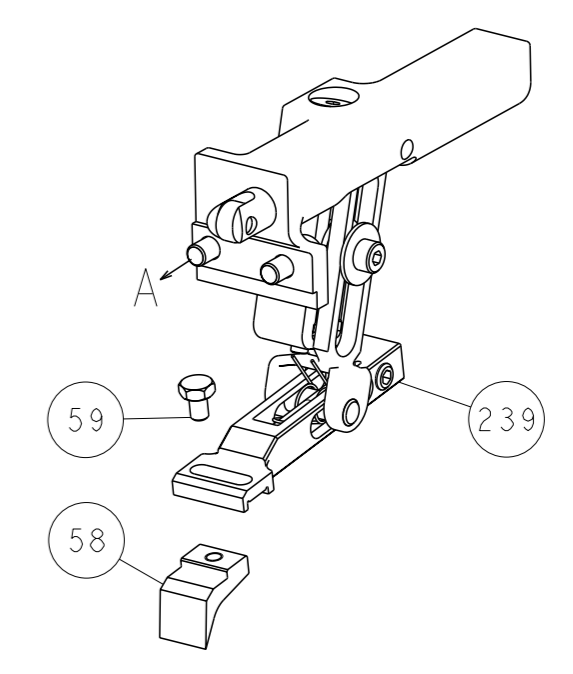

PNEUMATIC

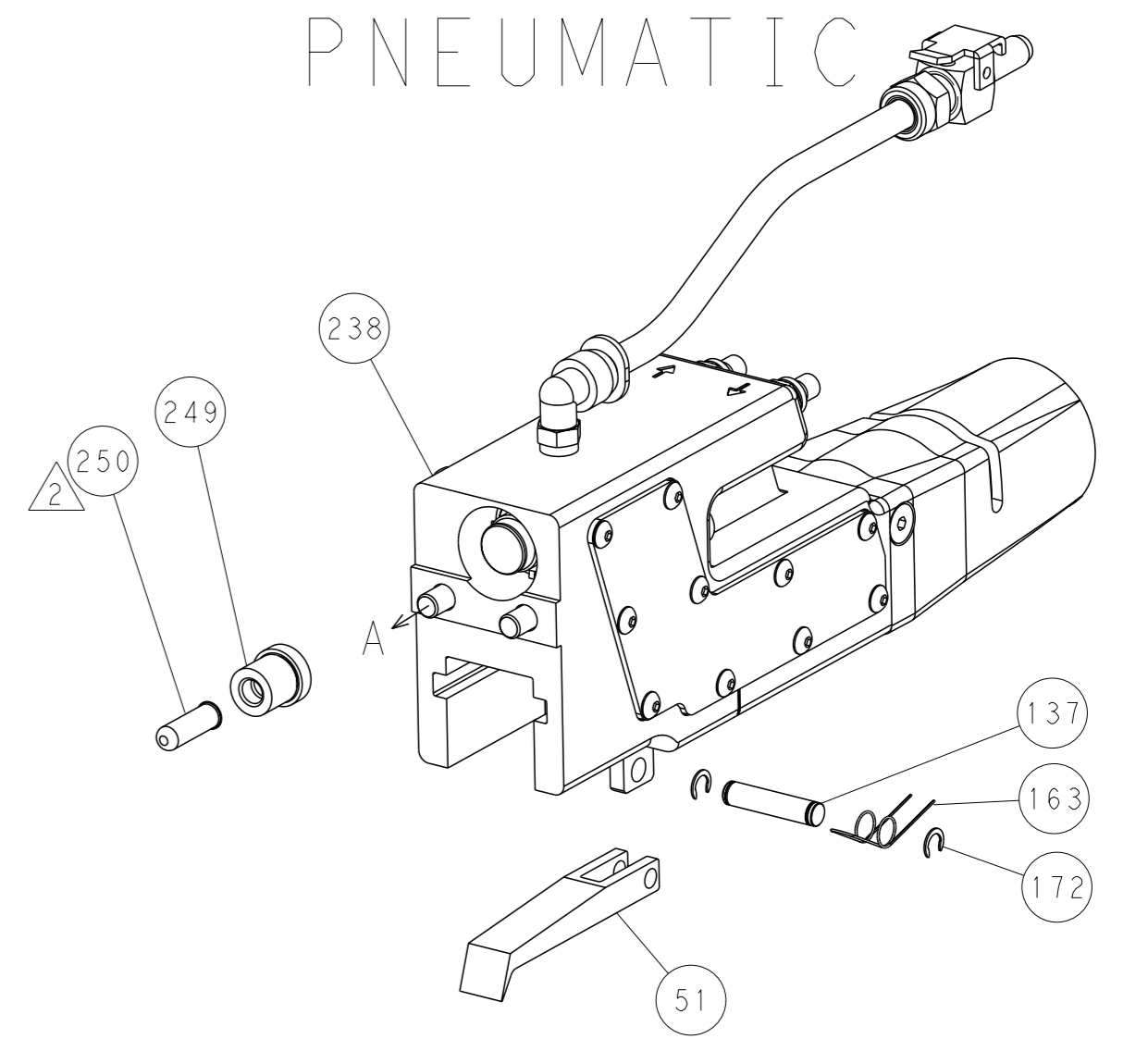

SERVO  
LATCH PLATE

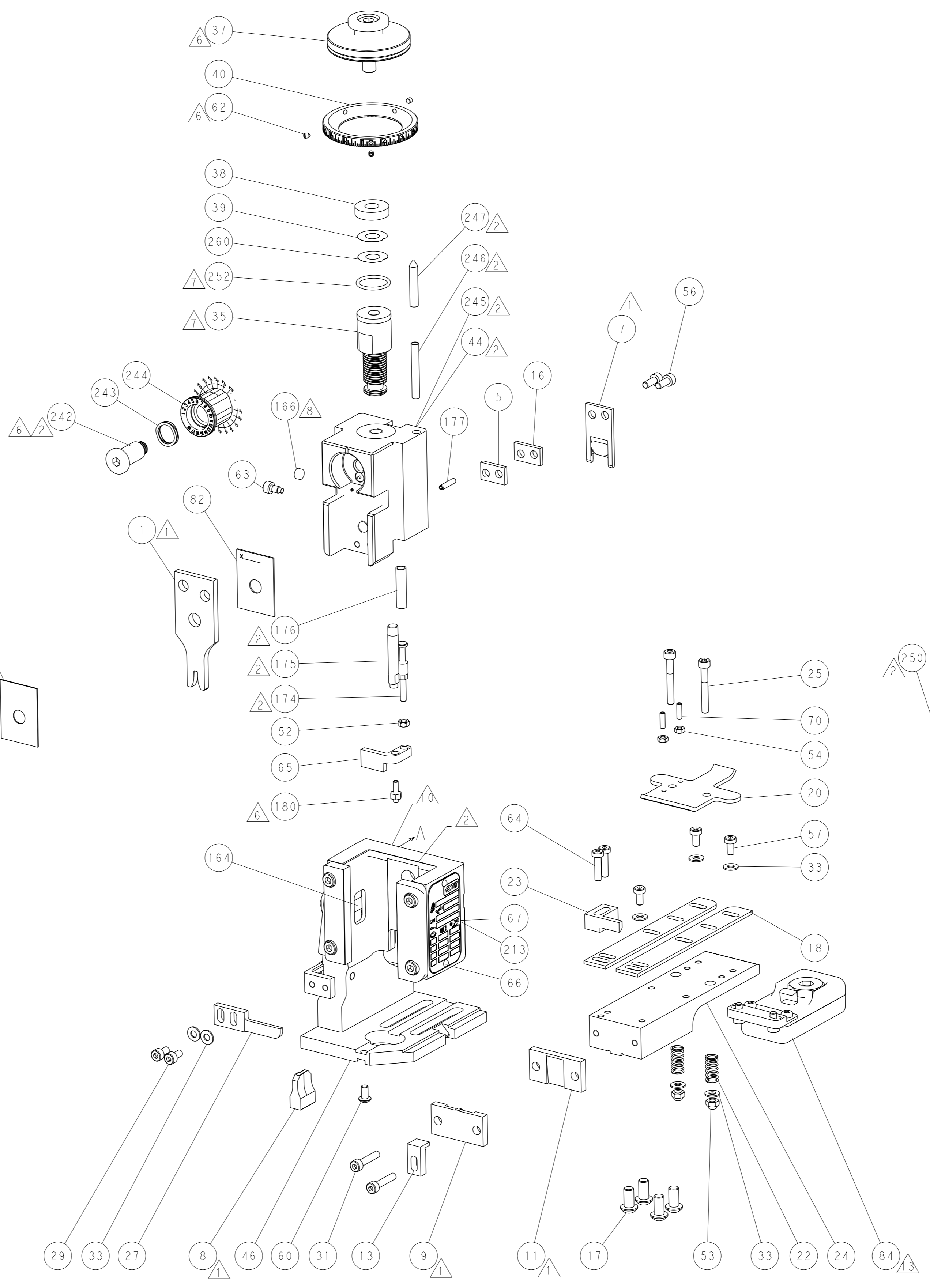
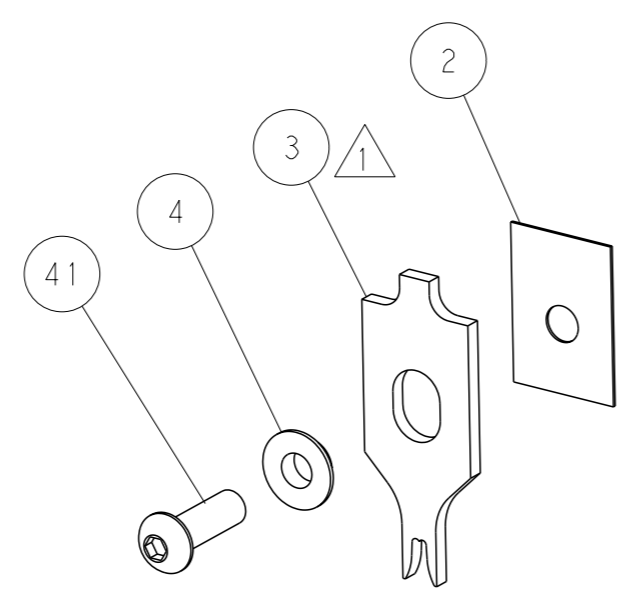
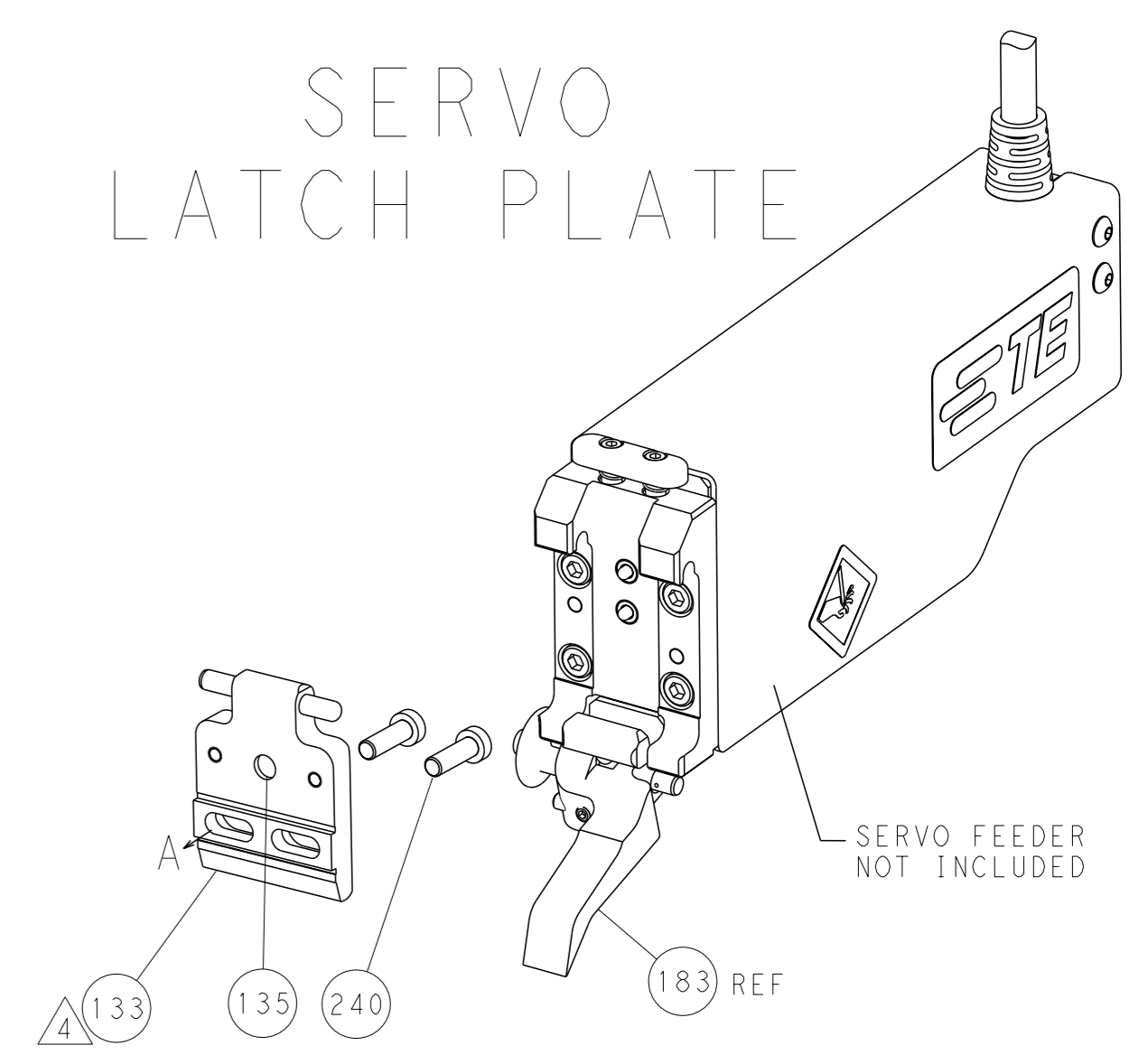

CAM POSITIONS

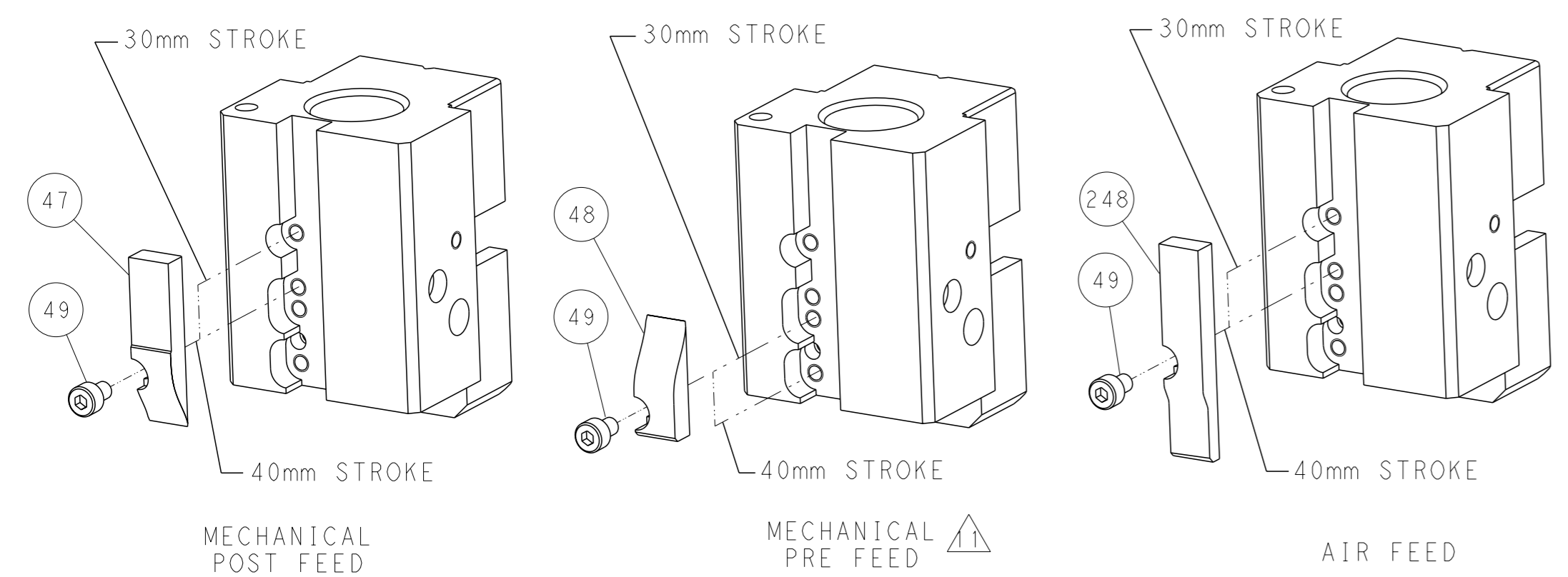

ATLANTIC VERSION  
 Shown on sheets 1 of 4 & 2 of 4  
 (Pacific version shown on sheets 3 of 4 & 4 of 4)

DIMENSIONS: mm 		TOLERANCES UNLESS OTHERWISE SPECIFIED: 0 PLC ± 1 PLC ± 2 PLC ± 3 PLC ± 4 PLC ± ANGLES ° ± FINISH		OWN M. HERR 21MAR2017 CHK T. ELBIN 21MAR2017 APVD T. ELBIN 21MAR2017 PRODUCT SPEC APPLICATION SPEC WEIGHT MATERIAL		NAME Ocean End Feed Applicator SIZE CAGE CODE DRAWING NO A1 00779 C=2150789 Customer Accessible Production Drawing		TE Connectivity Harrisburg, PA 17105-3608 RESTRICTED TO SCALE 1:1 SHEET 2 of 4 REV A	
-----------------------	--	---	--	--	--	--	--	---	--

PACIFIC VERSION TERMINATOR INTERFACE ADAPTER	PART NUMBER	REVISION	DESCRIPTION	FEED TYPE	APPLICATOR STYLE CONVERSION CHART						
					CONVERT TO	PART NUMBERS REQUIRED					
	2-2150789-1	A	FINE CRIMP HEIGHT ADJUST	MECHANICAL	PNEUMATIC FEED	2119950-1	2119792-1	-	2119641-2	-	2063440-1
					SERVO LATCH PLATE	2119951-1	1901697-1	8-2150789-5	-	-	2168400-7 (QUANTITY 2)
					SMART APPLICATOR	2161326-1	-	8-2150789-4	-	-	-
	2-2150789-2	A	FINE CRIMP HEIGHT ADJUST	PNEUMATIC	MECHANICAL FEED	2119949-1	2063961-1	5-18022-5	2119653-2	-	-
					SERVO LATCH PLATE	2119951-1	1901697-1	8-2150789-5	-	-	2168400-7 (QUANTITY 2)
					SMART APPLICATOR	2161326-1	-	8-2150789-4	-	-	-
	2-2150789-5	A	FINE CRIMP HEIGHT ADJUST	SERVO LATCH PLATE <sup>4</sup>	MECHANICAL FEED	2119949-1	2063961-1	5-18022-5	2119653-2	-	-
					PNEUMATIC FEED	2119950-1	2119792-1	-	2119641-2	-	2063440-1
	2-2150789-7	A	FINE CRIMP HEIGHT ADJUST	NONE	-	-	-	-	-	-	-
	7-2150789-7	A	CRIMP TOOLING KIT	-	-	-	-	-	-	-	-

APPLICATOR DATA		
CRIMP	SIZE	TYPE
WIRE	2.50 mm [.098]	F
INSUL	3.80 mm [1.50]	F
APPL INSTRUCTIONS 408-10390		

TERMINAL DATA: STOCKO TERMINAL STOCKO CRIMP SPECIFICATION	
TERMINAL NAME: RSB 8030 RECEPTACLE	
WIRE STRIP LENGTH 4.80-5.80 mm [1.89-.228 IN]	INSULATION DIAMETER RANGE Ø1.90-3.30 mm [1.075-.130 IN]
TERMINAL APPLICATION SPECIFICATION RSB 8030 F 6.3-1 Rev 29/10/2010	
TERMINALS APPLIED <sup>2</sup>	
TE TERMINAL 2303738-1	STOCKO TERMINAL RSB 8030 F 6.3-1

WIRE SIZE	CRIMP HEIGHT mm [INCH]	CRIMP HEIGHT REFERENCE SETTING <sup>9</sup>
1.50mm2	1.85 +/- 0.02 [1.073 +/- .001]	7.2
1.00mm2	1.68 +/- 0.02 [1.066 +/- .001]	9.0
0.75mm2	1.58 +/- 0.02 [1.062 +/- .001]	10.2
0.50mm2	1.50 +/- 0.02 [1.059 +/- .001]	11.1

- RECOMMENDED SPARE PARTS
- GREASE BEARING SURFACES LIGHTLY
- 3. LUBRICATE DAILY PER THE APPLICATOR INSTRUCTION SHEET SUPPLIED WITH THE APPLICATOR.
- APPLICATOR SPECIFIC DATA TO BE ENTERED INTO BLANK MEMORY CHIP AT ASSEMBLY. SEE BELOW FOR PART NUMBER:  
 MECHANICAL FEED WITH "SMART APPLICATOR" CONVERSION: 8-2150789-4  
 PNEUMATIC FEED WITH "SMART APPLICATOR" CONVERSION: 8-2150789-4  
 SERVO FEED WITH "FINE CRIMP HEIGHT ADJUST": 8-2150789-5
- 5. ADJUSTMENT OF THE STRIPPER MAY BE REQUIRED WHEN MOVING THE APPLICATOR BETWEEN BENCH AND LEADMAKER APPLICATIONS.
- APPLY PART NUMBER 1-23419-5 LOCTITE TO THREADS OF ITEMS 62 & 180. APPLY PART NUMBER 2-23419-6 LOCTITE TO THREADS OF ITEM 242.
- GREASE THREADS, GROOVE AND O-RING ON ITEMS 139 & 153.
- MAGNET, ITEM 166 MUST BE ORIENTED CORRECTLY IN ORDER TO PROPERLY ACTUATE THE COUNTER.
- CRIMP HEIGHT REFERENCE SETTING WAS THE SETTING USED WHEN THE APPLICATOR WAS QUALIFIED AT THE FACTORY. ADJUSTMENT MAY BE NECESSARY WHEN RUNNING APPLICATOR IN THE FIELD.
- SPARE FEED CAM STORAGE LOCATION REFER TO INSTRUCTION SHEET FOR ADDITIONAL INFORMATION.
- THE RECOMMENDED SET-UP FOR END FEED APPLICATORS IS POST-FEED WITH ITEM 2119653-1. THE APPLICATOR CAN BE CONFIGURED FOR PRE-FEED WITH ITEM 2119652-1 BUT MAY ENCOUNTER PROBLEMS WITH SOME APPLICATIONS. FEED ISSUES OR TERMINAL JAMMING MAY OCCUR IN THE PRE-FEED CONFIGURATION.
- TERMINAL LUBRICANT IS RECOMMENDED.

**\*WARNING**  
 ON INSTALLATION, SET WIRE DISC, ITEM 40 TO LARGEST WIRE SIZE SETTING. USE OF SETTINGS BELOW MINIMUM REQUIRED CRIMP HEIGHT SETTING WILL CAUSE DAMAGE TO CRIMP TOOLING.

-	1	1	1	1	2119782-1	FINE ADJUST HEAD ASM, PACIFIC STYLE	251
-	-	-	1	-	2119640-1	PUSH ROD, AIR FEED	250
-	-	-	1	-	1803259-1	BUSHING, FLANGED	249
-	1	1	1	1	1-22279-3	SPRING, COMPRESSION	246
-	1	1	1	1	2119082-4	CAM, SNAIL, INSULATION ADJUSTMENT	244
-	1	1	1	1	2079764-1	WASHER, WAVE SPRING, CREST-TO-CREST	243
	1	1	1	1	2119083-1	RETAINER, INSULATION DIAL	242
-77-27-25-22-21	PART NO		DESCRIPTION		ITEM NO		

**PACIFIC VERSION**  
 Shown on sheets 3 of 4 & 4 of 4  
 (Atlantic version shown on sheets 1 of 4 & 2 of 4)

SET UP GAUGE	LOC	DIST	REVISIONS			
2119599-2	A	66	REV	DATE	BY	APPV
			-	-	-	-
			SEE SHEET 1			

-	-	2	-	-	2168400-7	SHCS, LOW HEAD, RoHS, M5 X 10	240	
-	-	-	-	1	2119580-1	MECHANICAL FEED ASSEMBLY	239	
-	-	-	-	1	2063440-1	AIR FEED MODULE	238	
-	-	1	-	-	2119740-2	TAG, IDENTIFICATION	213	
-	4	4	4	4	2079383-9	SCR, BHSC, RoHS (M6 X 20)	186	
-	-	REF	-	-	1901697-1	FEED FINGER ASSEMBLY, EF	183	
	-	1	1	1	1	1976055-8	STANDOFF, HOLD-DOWN	180
-	1	1	1	1	6-993111-6	PIN, SLOTTED SPRING 3.0 X 14.0	177	
-	1	1	1	1	8-22280-7	SPRING, COMPRESSION	176	
-	1	1	1	1	1752353-2	GUIDE PIN, HOLDDOWN	175	
-	1	1	1	1	1901680-2	GUIDE PIN, HOLDDOWN	174	
-	-	-	2	-	21045-3	RING, RETAIN, EXTERN, 3/16 CRESCENT	172	
	-	1	1	1	1	994969-1	MAGNET, RARE EARTH HIGH ENERGY	166
-	REF	REF	REF	REF	994970-2	COUNTER, MAGNETIC	164	
-	-	-	1	-	240638-1	SPRING, FEED FINGER	163	
	-	1	1	1	1	8-21084-1	O-RING, .801 ID, .070 DIA. MAT.	153
-	-	-	1	-	2119641-2	FEED CAM, AIR FEED	152	
-	1	1	1	1	2119798-2	DETENT PIN	145	
-	1	1	1	1	2079383-8	SCR, BHSC, RoHS (M4 X 16)	144	
-	-	-	-	1	2119653-2	FEED CAM, POST FEED	142	
-	1	1	1	1	2119655-6	APPLICATOR BASIC ASSEMBLY, EF	141	
-	1	1	1	1	2119651-1	RAM, ASIAN STYLE, END FEED	140	
	-	1	1	1	1	2119092-2	BOLT, ADJUSTMENT	139
-	-	-	-	1	3-23627-7	PIN, RETAIN, GRVD, 3/16 X .854	137	
-	-	REF	-	-	-	SEE NOTE 4	MEMORY CHIP, PROGRAMMED	135
-	-	1	-	-	1633743-1	SERVO FEED LATCH ASM	133	
	-	1	1	1	1	2119955-2	ASSY, LUBRICATOR, END FEED	84
-	1	1	1	1	455888-7	SPACER, CRIMPER	82	
-	1	1	1	1	2119956-2	DOCUMENTATION PACKAGE	71	
-	2	2	2	2	2-18032-2	SCR, SET, FLT POINT M3 X 10.0	70	
-	1	-	1	1	2119740-1	TAG, IDENTIFICATION	67	
-	2	2	2	2	2168078-1	SCREW, DRIVE, RH, RoHS, 2 x .188	66	
-	1	1	1	1	1901681-5	HOLDDOWN, TERMINAL	65	
-	2	2	2	2	2168400-8	SHCS, LOW HEAD, RoHS, M4 X 16	64	
	-	1	1	1	1	2119793-1	LIMITER, ADJUSTMENT BOLT	63
-	3	3	3	3	992763-5	SCR, SET, SOC, CONE POINT, M3 x 4.0	62	
-	-	-	-	1	5-18022-5	SCR, HEX HD CAP, M4 X 6.0	59	
-	-	-	-	1	2063961-1	FEED FINGER	58	
-	3	3	3	3	2168400-4	SHCS, LOW HEAD, RoHS, M4 X 8	57	
-	2	2	2	2	1-2168083-0	SCR, SKT HD CAP, RoHS, M4 X 10	56	
-	2	2	2	2	5018030-1	NUT, HEX, REG, RoHS, M3	54	
-	2	2	2	2	986965-8	NUT, LOCK, HEX, TORQUE (M4)	53	
-	1	1	1	1	1-5018030-0	NUT, HEX, REG, RoHS, M3.5	52	
-	-	-	1	-	2119792-1	PAWL, EF, AIR	51	
-	-	-	1	2	18023-9	SCR, SKT HD CAP M4 X 6.0	49	
-	-	-	-	1	2119652-1	FEED CAM, PRE FEED	48	
-	1	1	1	1	2079383-7	SCR, BHSC, RoHS (M8 X 25)	41	
-	1	1	1	1	2119645-1	DISC, NUMBERED FA WIRE ADJUSTMENT	40	
-	1	1	1	1	2119957-1	APPLICATOR SHIM PACK	39	
-	1	1	1	1	2119644-2	RAM WASHER, PRECISION	38	
-	7	7	7	7	1-18028-2	WASHER, FLAT, REG M4	33	
-	2	2	2	2	2168083-9	SCR, SKT HD CAP, RoHS, M4 X 20	31	
-	2	2	2	2	2168083-2	SCR, SKT HD CAP, RoHS, M4 X 8.0	29	
-	1	1	1	1	240639-1	STRIPPER (MACHINING)	27	
-	2	2	2	2	1-2168083-5	SCR, SKT HD CAP, RoHS, M4 X 30	25	
-	1	1	1	1	1-1752371-6	PLATE, STRIP GUIDE	24	
-	1	1	1	1	240825-1	PLATE, STRIP HOLD DOWN	23	
-	2	2	2	2	2-22281-3	SPRING, COMPRESSION	22	
-	1	1	1	1	1803292-4	DRAG	20	
-	2	2	2	2	1901259-4	GUIDE, LOWER STRIP	18	
-	1	1	1	1	1-240641-6	SPACER	16	
-	1	1	1	1	1752360-1	SPACER, HOLD-DOWN	13	
	-	1	1	1	1	240644-5	PLATE, REAR SHEAR	11
-	-	-	-	-	-	-	10	
	-	1	1	1	1	5-690495-2	PLATE, FRONT SHEAR	9
	1	1	1	1	1	2-1803257-7	ANVIL, COMBINATION, END FEED	8
	-	1	1	1	1	1-2217206-0	BLADE, SLUG	7
-	-	-	-	-	-	-	6	
-	1	1	1	1	1	1338708-1	SPACER, SLUG BLADE	5
-	1	1	1	1	1	4-238009-1	BLOCK, FL CRIMPER SPACER	4
	1	1	1	1	1	7-1803187-1	CRIMPER, INSULATION F	3
-	1	1	1	1	1	455888-5	SPACER, CRIMPER	2
	1	1	1	1	1	1-1803188-6	CRIMPER, WIRE	1
-77-27-25-22-21	PART NO		DESCRIPTION		ITEM NO			

DIMENSIONS:		TOLERANCES UNLESS OTHERWISE SPECIFIED:		OWN	CHK	APPV	DATE	NAME					
mm	0 PLC ±	1 PLC ±	2 PLC ±	M	HERR	T	21MAR2017	STE TE Connectivity					
	3 PLC ±	4 PLC ±	ANGLES FINISH		ELBIN		21MAR2017	Harrisburg, PA 17105-3608					
								Ocean End Feed Applicator					
MATERIAL								SIZE	CAGE CODE	DRAWING NO	RESTRICTED TO		
								A1	00779	©=2150789			
Customer Accessible Production Drawing								SCALE	1:1	SHEET	3 of 4	REV	A



LOC		DIST		REVISIONS			
A	66	P	LYR	DESCRIPTION	DATE	OWN	APVD
		-		SEE SHEET 1			

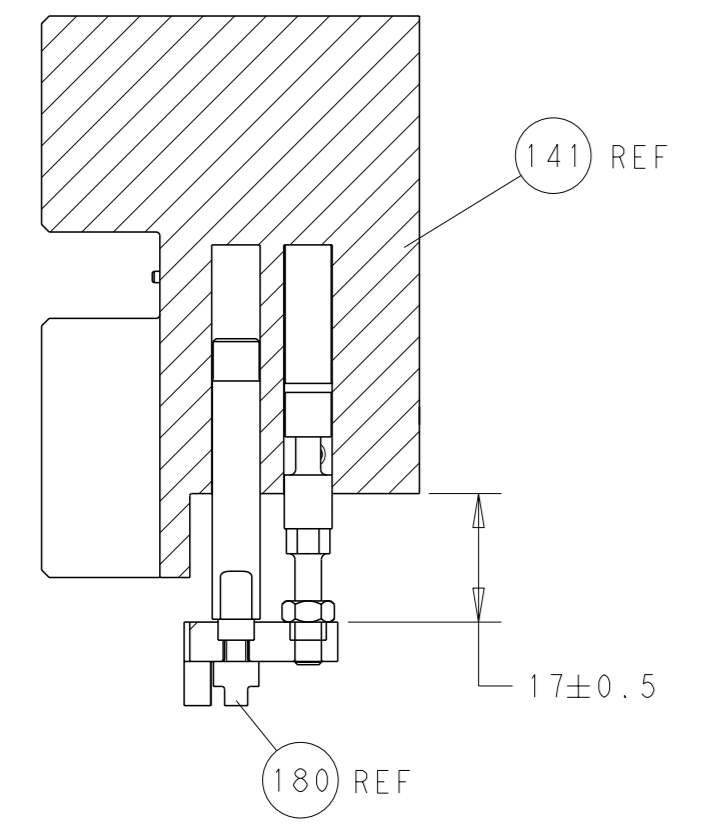

HOLDDOWN SET-UP

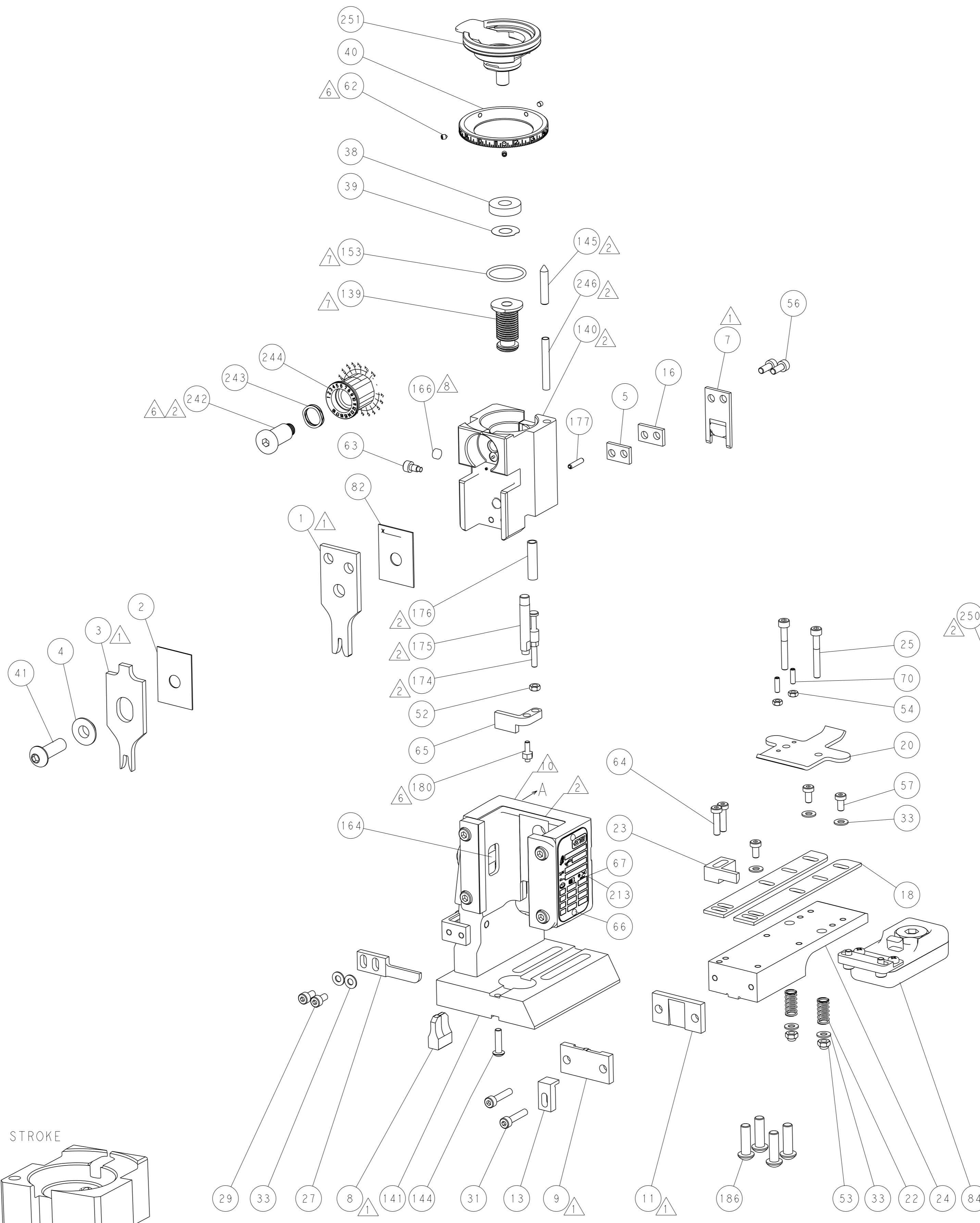

FEED TYPE  
MECHANICAL

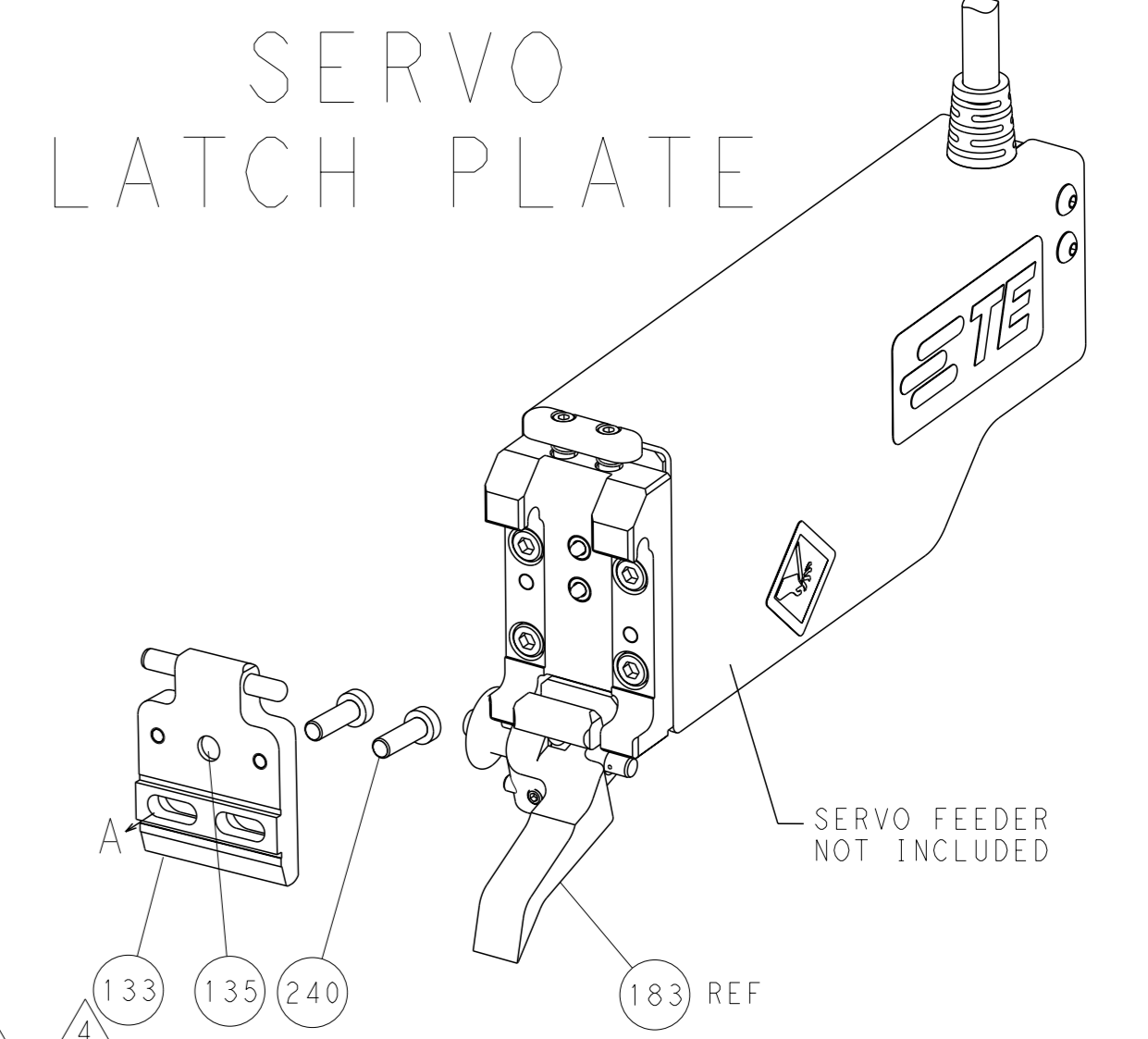
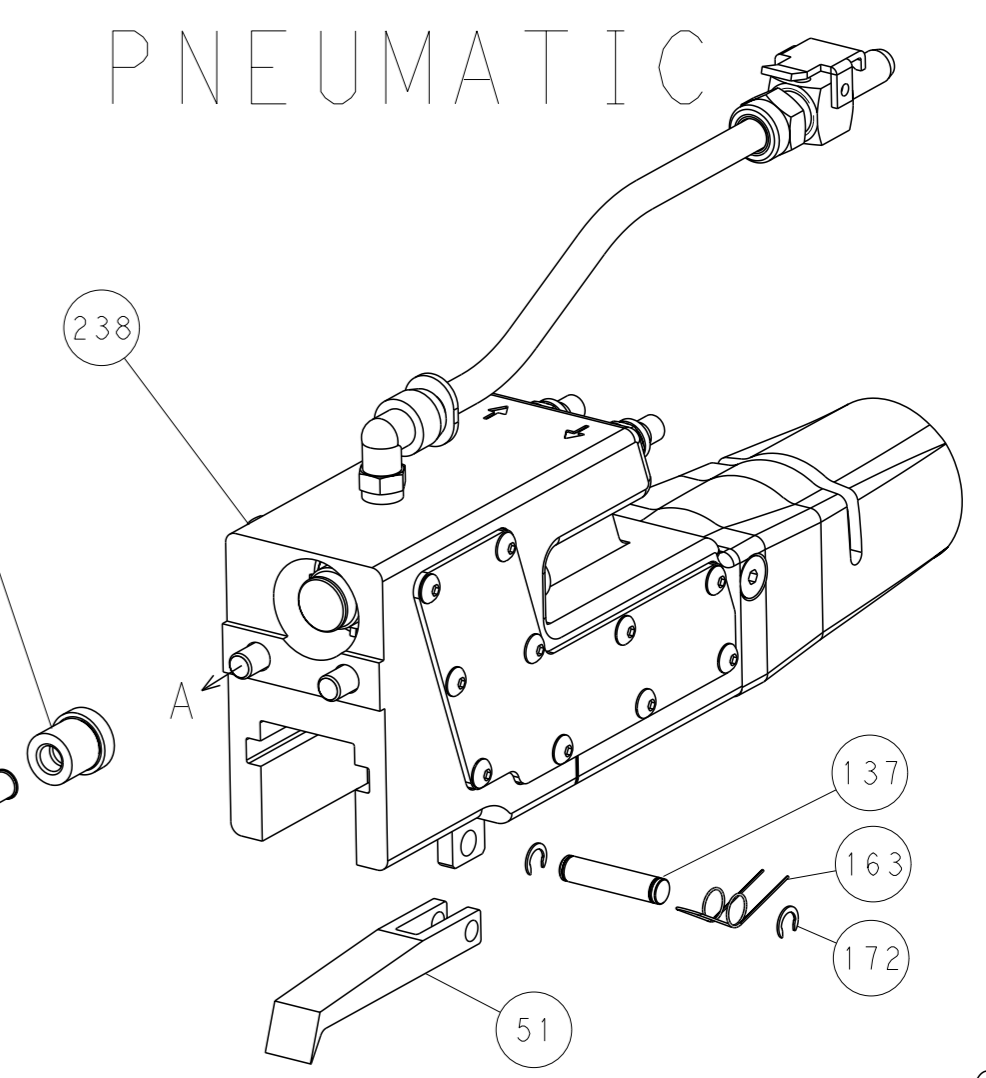
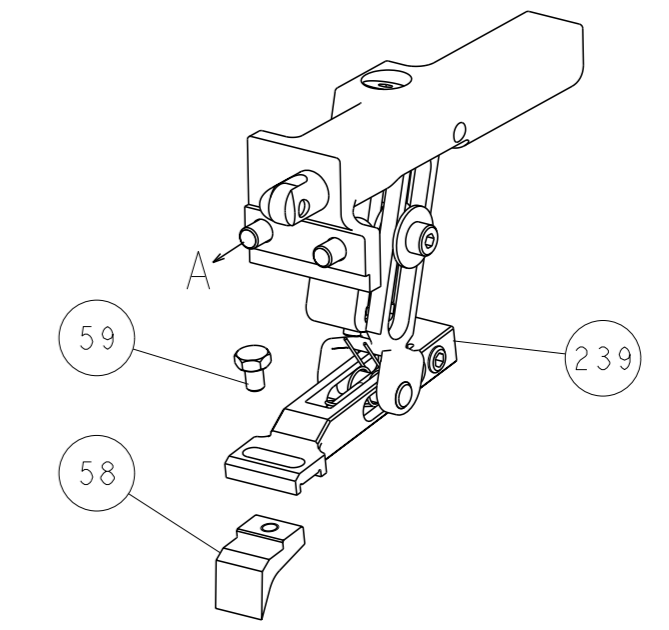

CAM POSITIONS

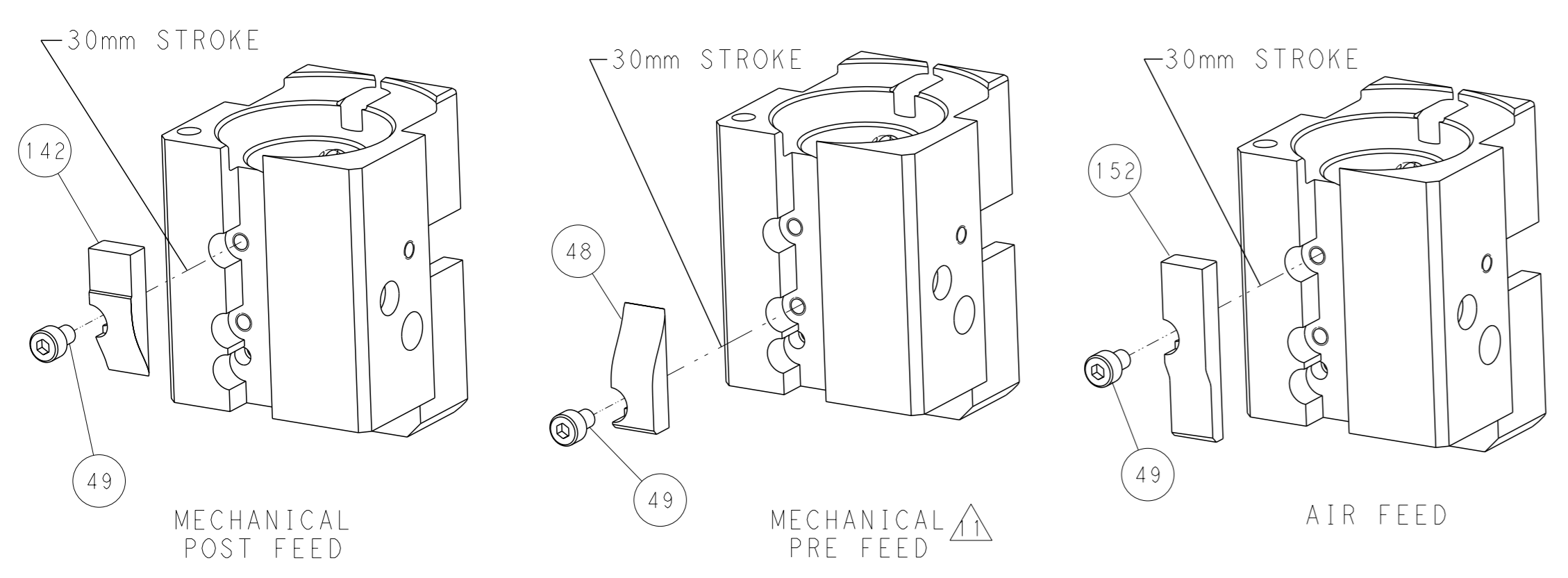

PACIFIC VERSION  
 Shown on sheets 3 of 4 & 4 of 4  
 (Atlantic version shown on sheets 1 of 4 & 2 of 4)

DIMENSIONS:		TOLERANCES UNLESS OTHERWISE SPECIFIED:		OWN: M. HERR 21MAR2017		STE TE Connectivity	
mm	0 PLC ±	1 PLC ±	2 PLC ±	CWK: T. ELBIN 21MAR2017	NAME: Ocean End Feed Applicator		Harrisburg, PA 17105-3608
	3 PLC ±	4 PLC ±	ANGLES ±	APVD: T. ELBIN 21MAR2017	SIZE: A1		Customer Accessible Production Drawing
MATERIAL:	FINISH:	WEIGHT:	SCALE: 1:1	CAGE CODE: 00779		DRAWING NO: C-2150789	RESTRICTED TO: A
				SHEET 4 OF 4		REV A	