

LOC	DIST	REV	DESCRIPTION	DATE	OWN	APVD
A	66		SEE SHEET 1			

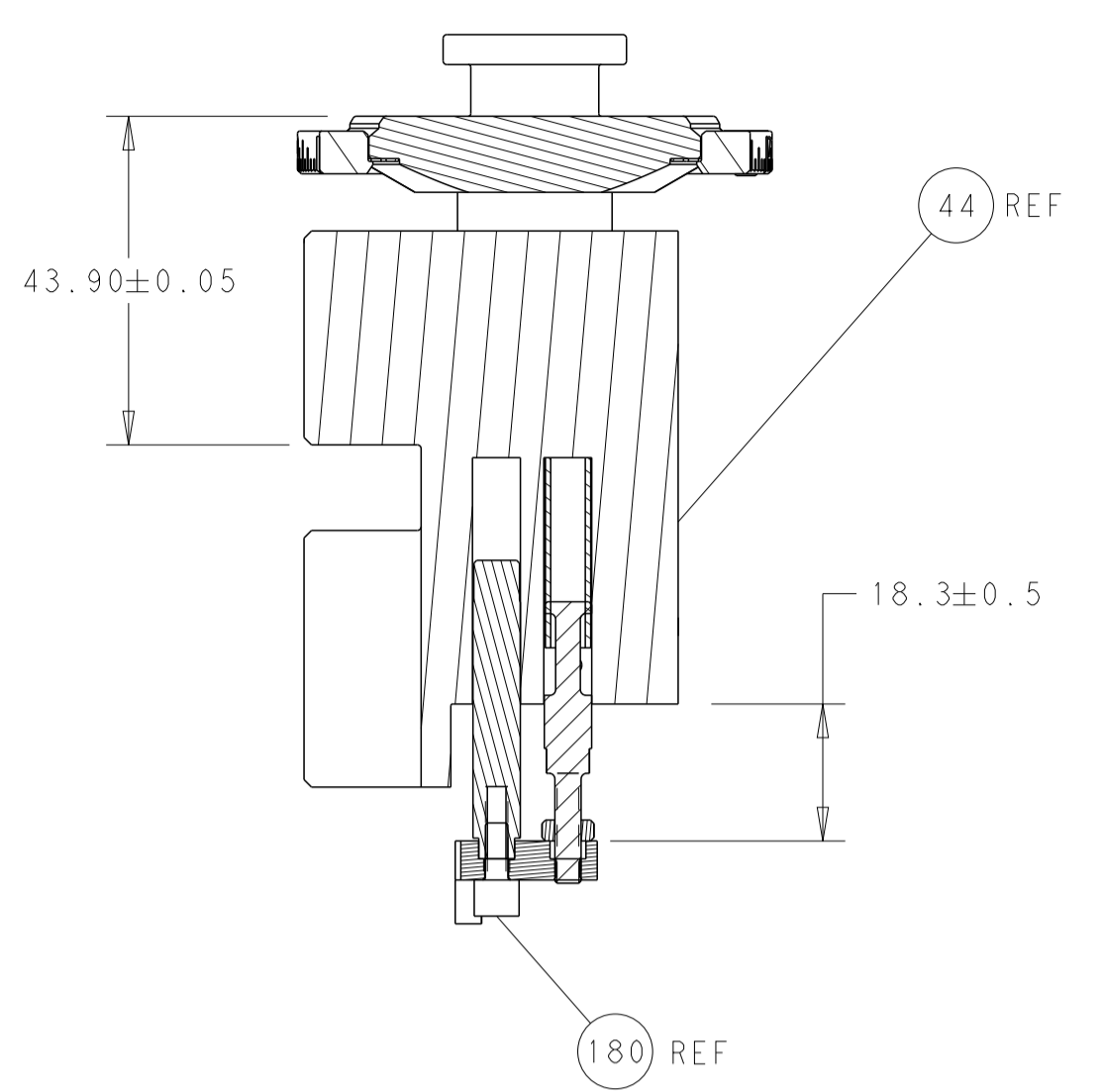

RAM AND HOLDDOWN SET-UP

FEED TYPE
MECHANICAL

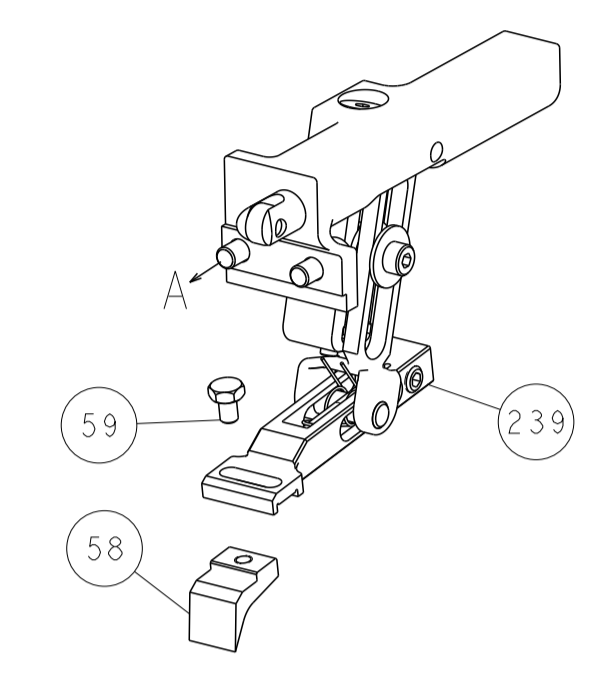

PNEUMATIC

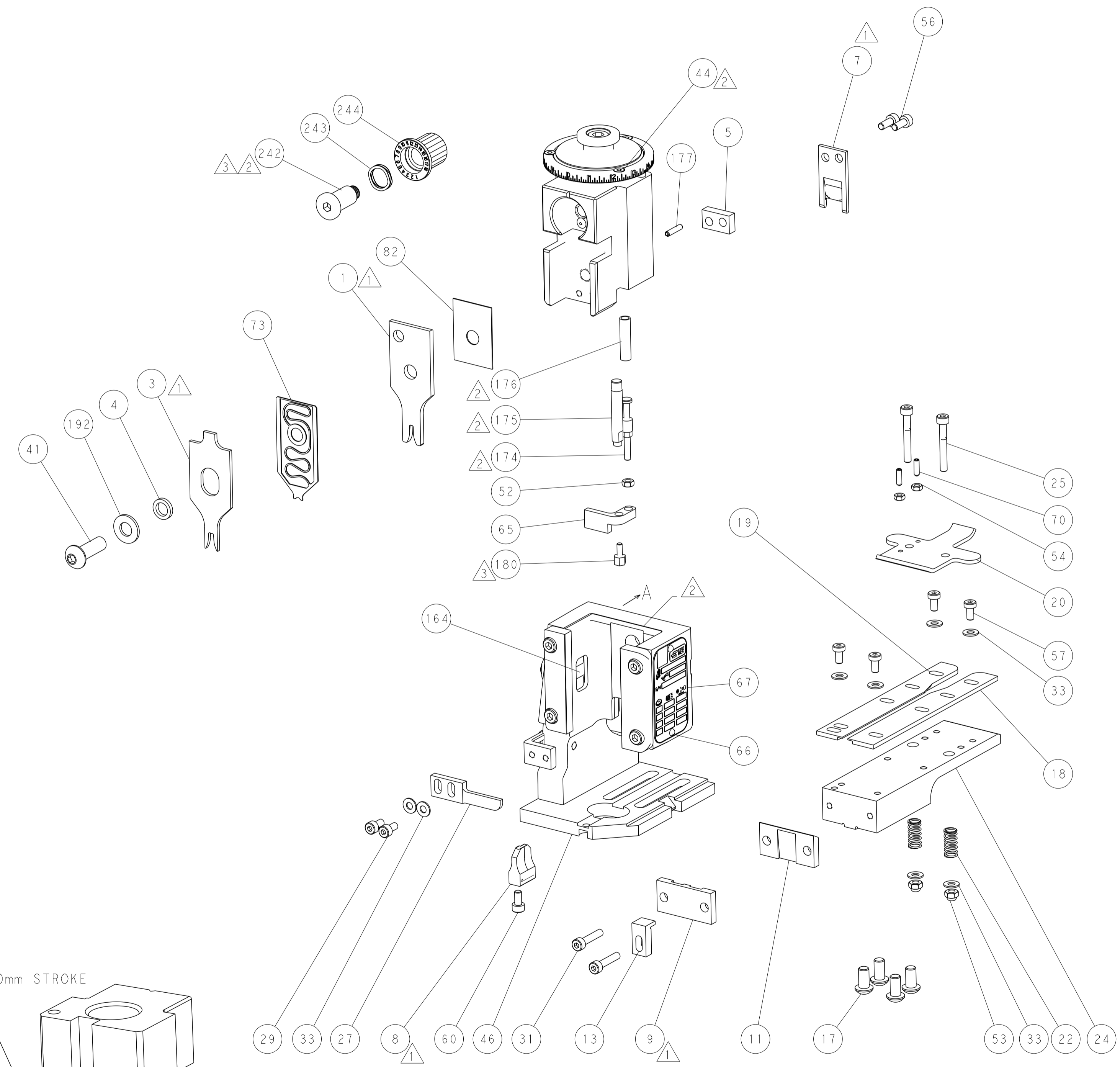
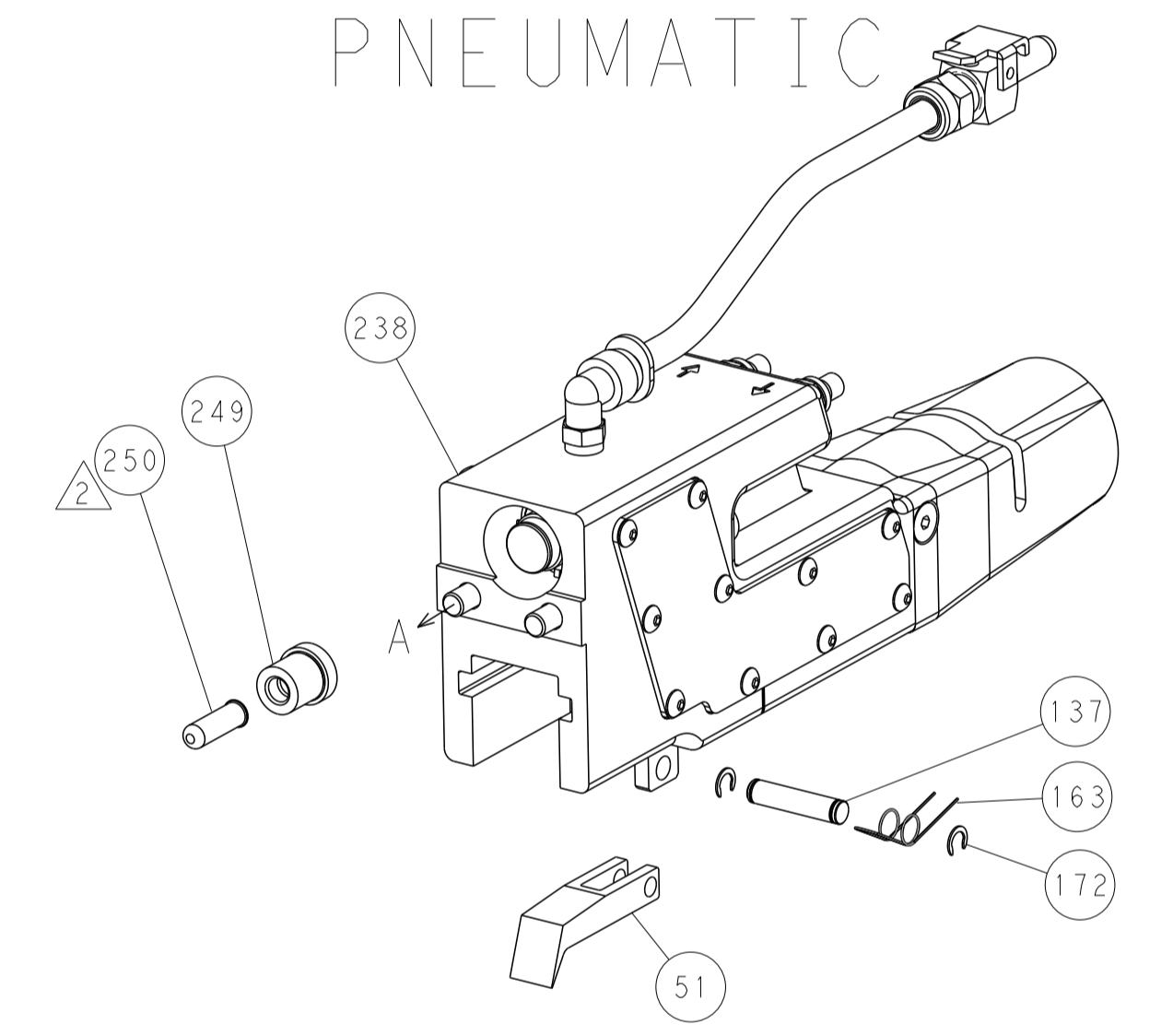

CAM POSITIONS

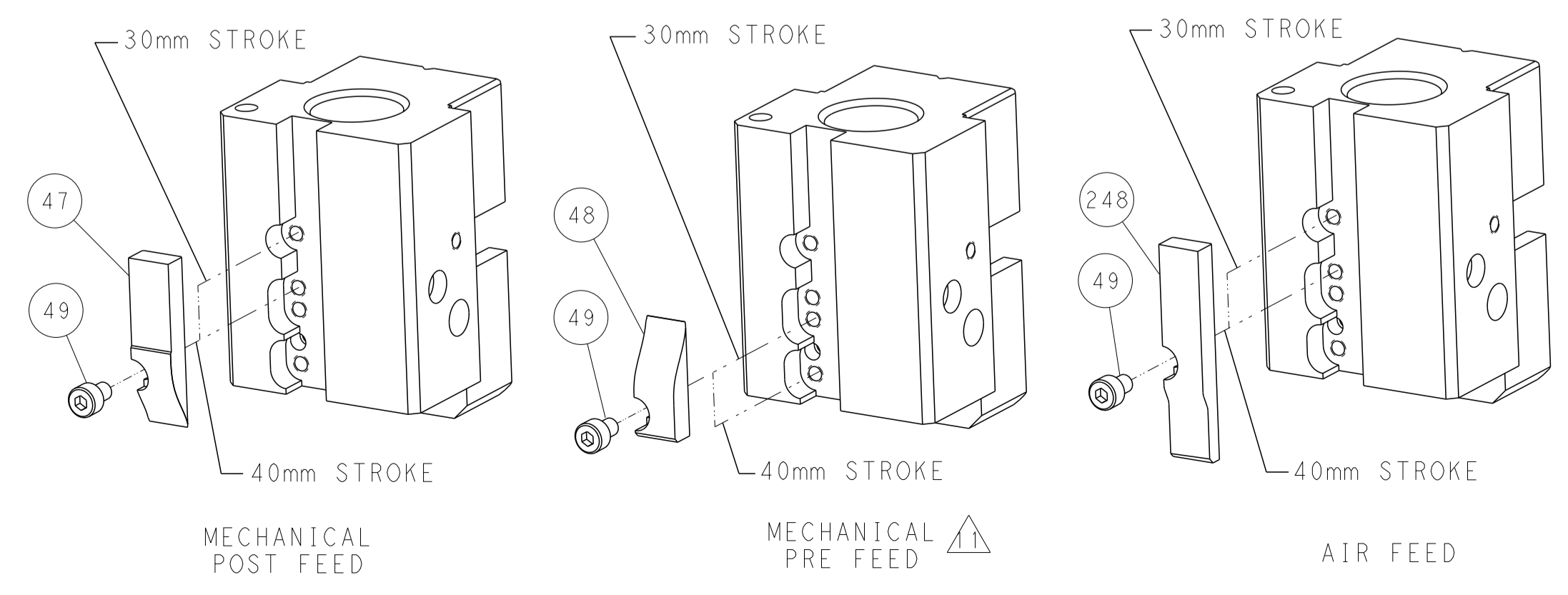

ATLANTIC VERSION
 Shown on sheets 1 of 4 & 2 of 4
 (Pacific version shown on sheets 3 of 4 & 4 of 4)

DIMENSIONS: mm 		TOLERANCES UNLESS OTHERWISE SPECIFIED: 0 PLC ± 1 PLC ± 2 PLC ± 3 PLC ± 4 PLC ± ANGLES ± FINISH ±		DWN M. ZHAO 12MAY2016 CHK K. ZHANG 12MAY2016 APVD K. ZHANG 12MAY2016 NAME Ocean End Feed Applicator SIZE CAGE CODE DRAWING NO. RESTRICTED TO A1 00779 ©=2150675 Customer Accessible Production Drawing SCALE 1:1 SHEET 2 OF 4 REV B	
MATERIAL:		WEIGHT:		TE Connectivity Harrisburg, PA 17105-3608	

PART NUMBER	REVISION	DESCRIPTION	FEED TYPE
2-2150675-1	B	FINE CRIMP HEIGHT ADJUST	MECHANICAL
2-2150675-2	B	FINE CRIMP HEIGHT ADJUST	PNEUMATIC
7-2150675-7	A	CRIMP TOOLING KIT	-

PACIFIC VERSION TERMINATOR
 INTERFACE ADAPTER

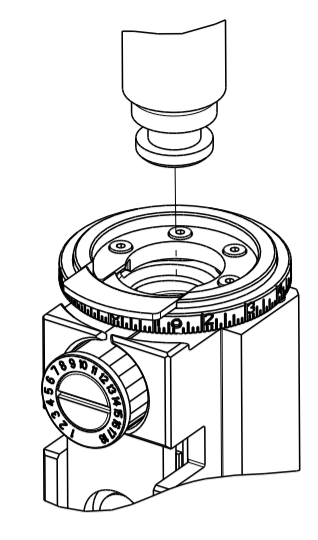

APPLICATOR DATA

CRIMP	SIZE	TYPE
WIRE	2.29 mm (.090)	F
INSUL	3.56 mm (.140)	F

APPL INSTRUCTIONS
 408-35043

TERMINAL DATA: TE TERMINAL TE CRIMP SPECIFICATION

TERMINAL NAME: SHAKE PROOF RING TONGUE

WIRE STRIP LENGTH	INSULATION DIAMETER RANGE
4.80-5.60 mm (.189-.220 IN)	∅2.54-3.05 mm (.100-.120 IN)

TERMINAL APPLICATION SPECIFICATION 114-3118

TERMINALS APPLIED

TE TERMINAL	TE TERMINAL	TE TERMINAL	TE TERMINAL
154672-1	151382-1	151382-2	151382-3
154672-2			

TERMINAL DATA: TE TERMINAL TE CRIMP SPECIFICATION

TERMINAL NAME: SHAKE PROOF RING TONGUE

WIRE STRIP LENGTH	INSULATION DIAMETER RANGE
4.80-5.60 mm (.189-.220 IN)	∅2.79-3.30 mm (.110-.130 IN)

TERMINAL APPLICATION SPECIFICATION 114-3118

TERMINALS APPLIED

TE TERMINAL	TE TERMINAL	TE TERMINAL	TE TERMINAL
152301-1	152301-2	152301-3	

WIRE SIZE	CRIMP HEIGHT mm [INCH]	CRIMP HEIGHT REFERENCE SETTING
16 AWG	1.76 +/- 0.05 [.069 +/- .002]	7.0
1.00mm2	1.66 +/- 0.05 [.065 +/- .002]	8.0
18 AWG	1.59 +/- 0.05 [.063 +/- .002]	8.9
0.75mm2	1.58 +/- 0.05 [.062 +/- .002]	9.0
0.50mm2 OR 20 AWG	1.50 +/- 0.05 [.059 +/- .002]	10.0



- RECOMMENDED SPARE PARTS
- REFER TO SUPPLIED INSTRUCTION SHEET FOR CLEANING, LUBRICATION AND STORAGE OF APPLICATOR.
- APPLY PART NUMBER 2-23419-6 LOCTITE TO THREADS OF ITEM 242. APPLY PART NUMBER 1-23419-5 LOCTITE TO THREADS OF ITEM 180.
- CRIMP HEIGHT REFERENCE SETTING WAS THE SETTING USED WHEN THE APPLICATOR WAS QUALIFIED AT THE FACTORY. ADJUSTMENT MAY BE NECESSARY WHEN RUNNING APPLICATOR IN THE FIELD.
- UNLESS SPECIFIED OTHERWISE TORQUE VALUES SHALL BE USED PER DOCUMENT, 101-35000.

***WARNING**
 ON INSTALLATION, SET WIRE DISC TO CRIMP HEIGHT REFERENCE SETTING FOR LARGEST WIRE SIZE. CRIMP HEIGHT REFERENCE SETTINGS GREATER THAN THE VALUE SHOWN MAY CAUSE DAMAGE TO THE CRIMP TOOLING. REFER TO THE INSTRUCTION SHEET FOR PROPER SETUP AND ADJUSTMENTS.

LOC	DIST	REV	DATE	BY	APPD
A	66				

REV	DATE	BY	APPD	DESCRIPTION	QTY	
-	-	-	-	SEE SHEET 1	-	
-	1	-	-	2119640-1	PUSH ROD, AIR FEED	250
-	1	-	-	1803259-1	BUSHING, FLANGED	249
-	1	1	-	2119082-2	CAM, SNAIL, INSULATION ADJUSTMENT	244
-	1	1	-	2079764-1	WASHER, WAVE SPRING, CREST-TO-CREST	243
-	1	1	-	2119083-1	RETAINER, INSULATION DIAL	242
-	-	1	-	2119580-1	MECHANICAL FEED ASSEMBLY	239
-	1	-	-	2063440-1	AIR FEED MODULE	238
-	1	1	-	1-18028-0	WASHER, FLAT, REG M8	192
-	4	4	-	2079383-9	SCR, BHSC, RoHS (M6 X 20)	186
-	1	1	-	1752354-4	STANDOFF, HOLD-DOWN	180
-	1	1	-	6-993111-6	PIN, SLOTTED SPRING 3.0 X 14.0	177
-	1	1	-	8-22280-7	SPRING, COMPRESSION	176
-	1	1	-	1752353-2	GUIDE PIN, HOLDDOWN	175
-	1	1	-	1901680-2	GUIDE PIN, HOLDDOWN	174
-	2	-	-	21045-3	RING, RETAIN, EXTERN, 3/16 CRESCENT	172
-	REF	REF	-	994970-2	COUNTER, MAGNETIC	164
-	1	-	-	240638-1	SPRING, FEED FINGER	163
-	1	-	-	2119641-2	FEED CAM, AIR FEED	152
-	1	1	-	2168083-8	SCR, SKT HD CAP, RoHS, M4 X 16	144
-	-	1	-	2119653-2	FEED CAM, POST FEED	142
-	1	1	-	2119655-6	APPLICATOR BASIC ASSEMBLY, EF	141
-	1	1	-	1803518-1	RAM ASSEMBLY, EF PACIFIC	140
-	1	-	-	3-23627-7	PIN, RETAIN, GRVD, 3/16 X .854	137
-	1	1	-	455888-5	SPACER, CRIMPER	82
-	1	1	-	2119791-5	DEPRESSOR, WIRE	73
-	1	1	-	1803607-2	DOCUMENTATION PACKAGE	71
-	2	2	-	2-18032-2	SCR, SET, FLT PNT, M3 X 10.0	70
-	1	1	-	2119740-1	TAG, IDENTIFICATION	67
-	2	2	-	2168078-1	SCREW, DRIVE, RH, RoHS, 2 x .188	66
-	1	1	-	1901681-1	HOLDDOWN, TERMINAL	65
-	-	1	-	5-18022-5	SCR, HEX HD CAP, M4 X 6.0	59
-	-	1	-	2063961-1	FEED FINGER	58
-	4	4	-	2168400-4	SHCS, LOW HEAD, RoHS, M4 X 8	57
-	2	2	-	1-2168083-0	SCR, SKT HD CAP, RoHS, M4 X 10	56
-	2	2	-	5018030-1	NUT, HEX, REG, RoHS, M3	54
-	2	2	-	986965-8	NUT, LOCK, HEX, TORQUE (M4)	53
-	1	1	-	1-5018030-0	NUT, HEX, REG, RoHS, M3.5	52
-	1	-	-	2119792-2	PAWL, EF, AIR	51
-	1	2	-	18023-9	SCR, SKT HD CAP M4 X 6.0	49
-	-	1	-	2119652-1	FEED CAM, PRE FEED	48
-	1	1	-	1803602-1	SCR, BHSC, RoHS (M8 X 25)	41
-	8	8	-	1-18028-2	WASHER, FLAT, REG M4	33
-	2	2	-	2168083-9	SCR, SKT HD CAP, RoHS, M4 X 20	31
-	2	2	-	2168083-2	SCR, SKT HD CAP, RoHS, M4 X 8.0	29
-	1	1	-	240639-1	STRIPPER (MACHINING)	27
-	2	2	-	1-2168083-5	SCR, SKT HD CAP, RoHS, M4 X 30	25
-	1	1	-	1752371-5	PLATE, STRIP GUIDE	24
-	2	2	-	2-22281-3	SPRING, COMPRESSION	22
-	1	1	-	1803292-4	DRAG	20
-	1	1	-	4-1901696-4	STRIP GUIDE, REAR	19
-	1	1	-	4-1901695-4	STRIP GUIDE, FRONT	18
-	1	1	-	1752360-1	SPACER, HOLD-DOWN	13
-	1	1	-	240833-7	PLATE, REAR SHEAR	11
-	-	-	-	-	-	10
-	1	1	-	690482-6	PLATE, FRONT SHEAR	9
-	1	1	-	1-1333217-5	ANVIL, EF .090	8
-	1	1	-	2217206-4	BLADE, SLUG	7
-	-	-	-	-	-	6
-	1	1	-	1-240641-8	SPACER	5
-	1	1	-	238011-8	BLOCK, CRIMPER SPACER	4
-	1	1	-	2-2119582-4	CRIMPER, INSULATION F PREMIUM	3
-	-	-	-	-	-	2
-	1	1	-	2-456406-3	CRIMPER, WIRE PREMIUM	1
-	77-22-21			PART NO	DESCRIPTION	ITEM NO

PACIFIC VERSION
 Shown on sheets 3 of 4 & 4 of 4
 (Atlantic version shown on sheets 1 of 4 & 2 of 4)

DIMENSIONS: mm		TOLERANCES UNLESS OTHERWISE SPECIFIED:		DWG: M. ZHAO 12MAY2016		CHK: K. ZHANG 12MAY2016		APVD: K. ZHANG 12MAY2016		NAME: Ocean End Feed Applicator	
0 PLC ±		1 PLC ±		2 PLC ±		3 PLC ±		4 PLC ±		SIZE: A1	
ANGLES		FINISH		WEIGHT		SCALE: 1:1		SHEET: 3 OF 4		REV: B	
MATERIAL		FINISH		WEIGHT		SCALE: 1:1		SHEET: 3 OF 4		REV: B	

Customer Accessible Production Drawing

LOC	DIST	REV	DATE	BY	APPV
A	66				
REVISIONS			DESCRIPTION	DATE	BY
-			SEE SHEET 1	-	-

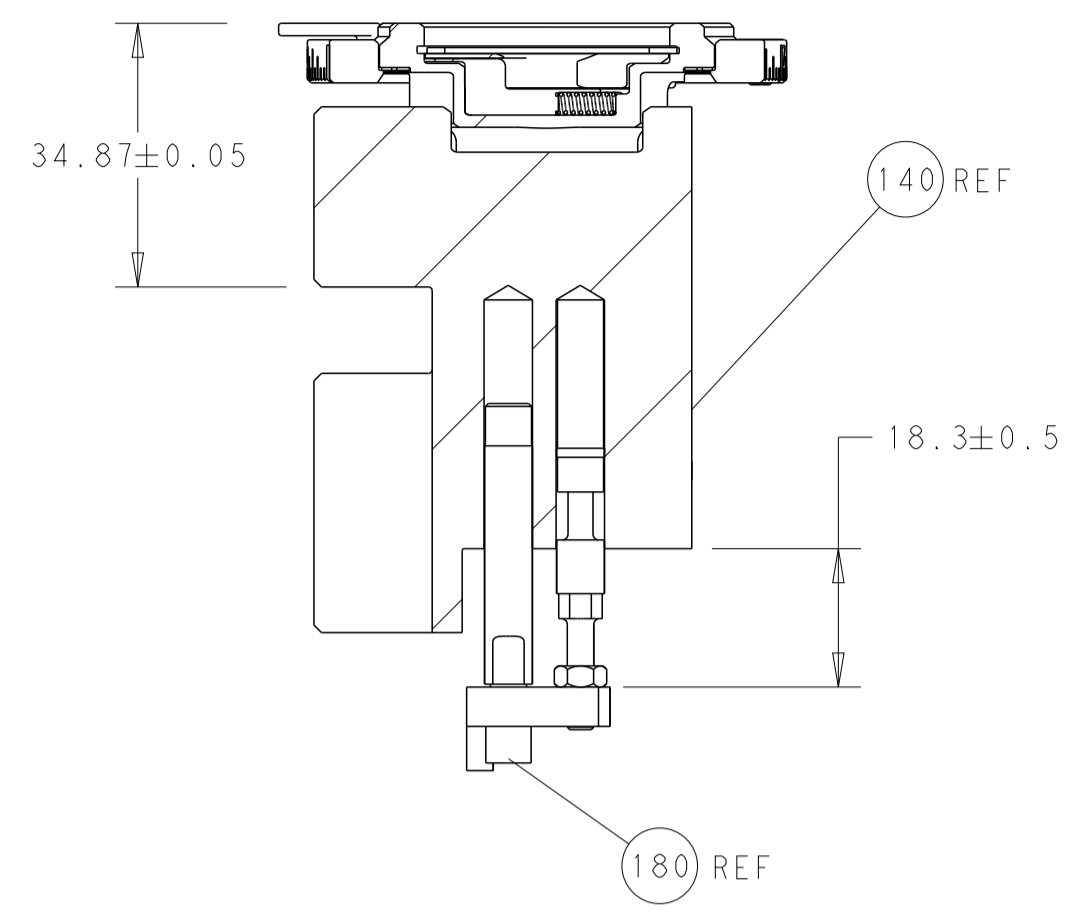

RAM AND HOLDDOWN SET-UP

FEED TYPE
MECHANICAL

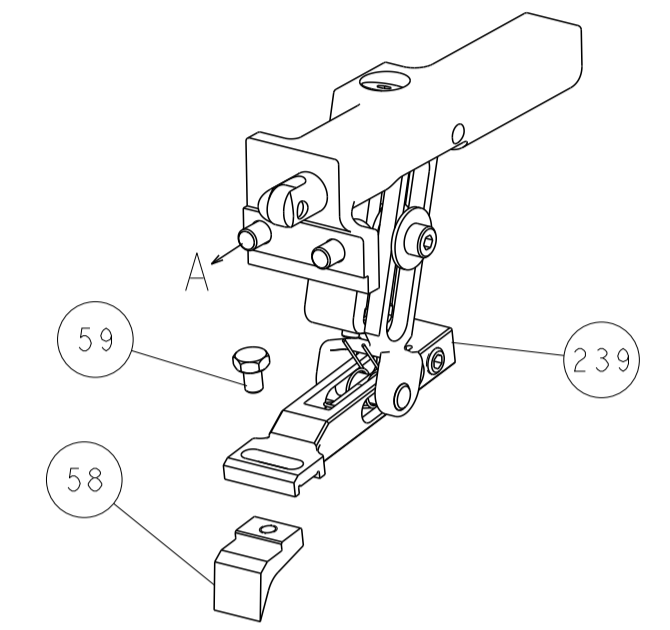

PNEUMATIC

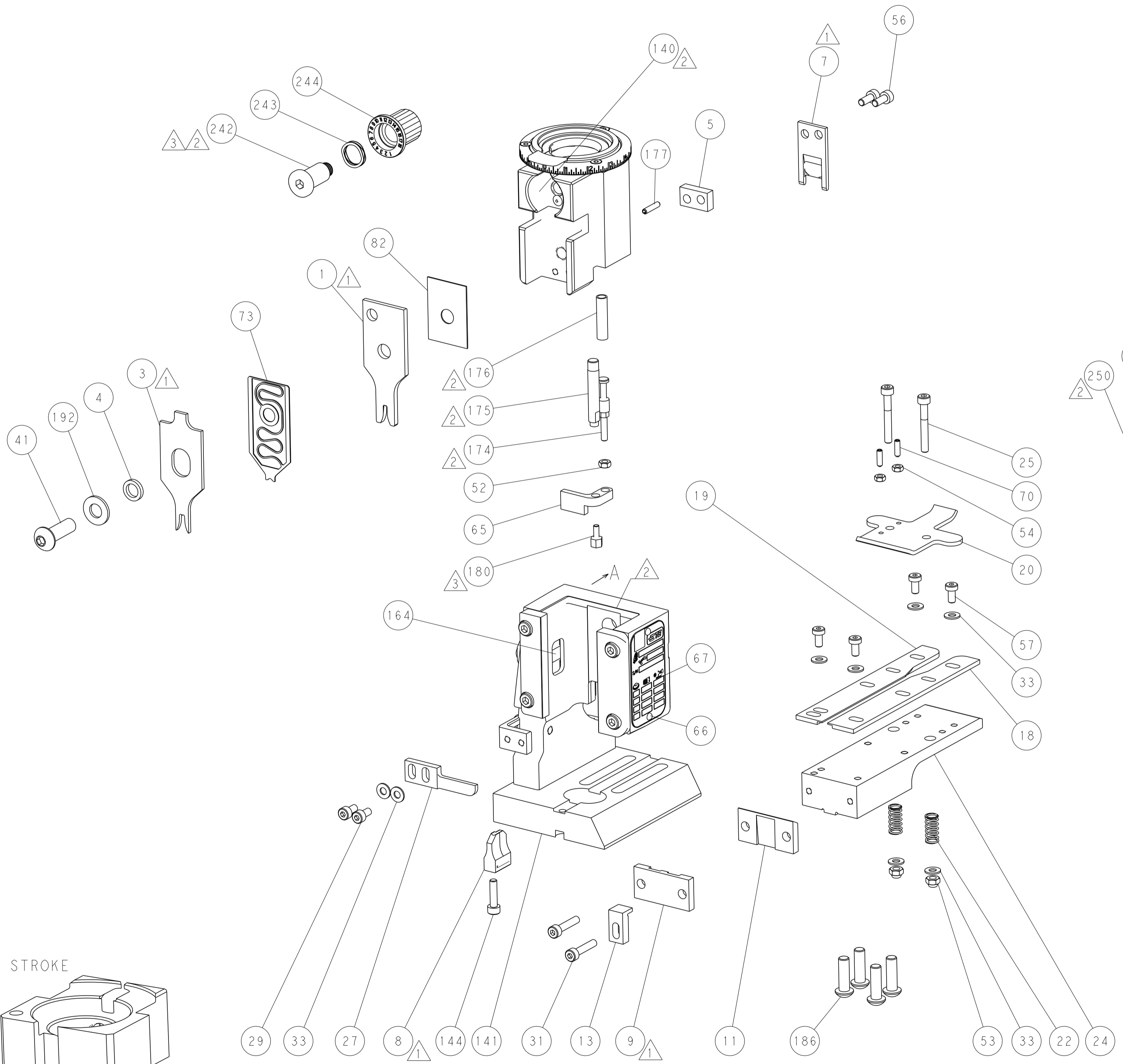
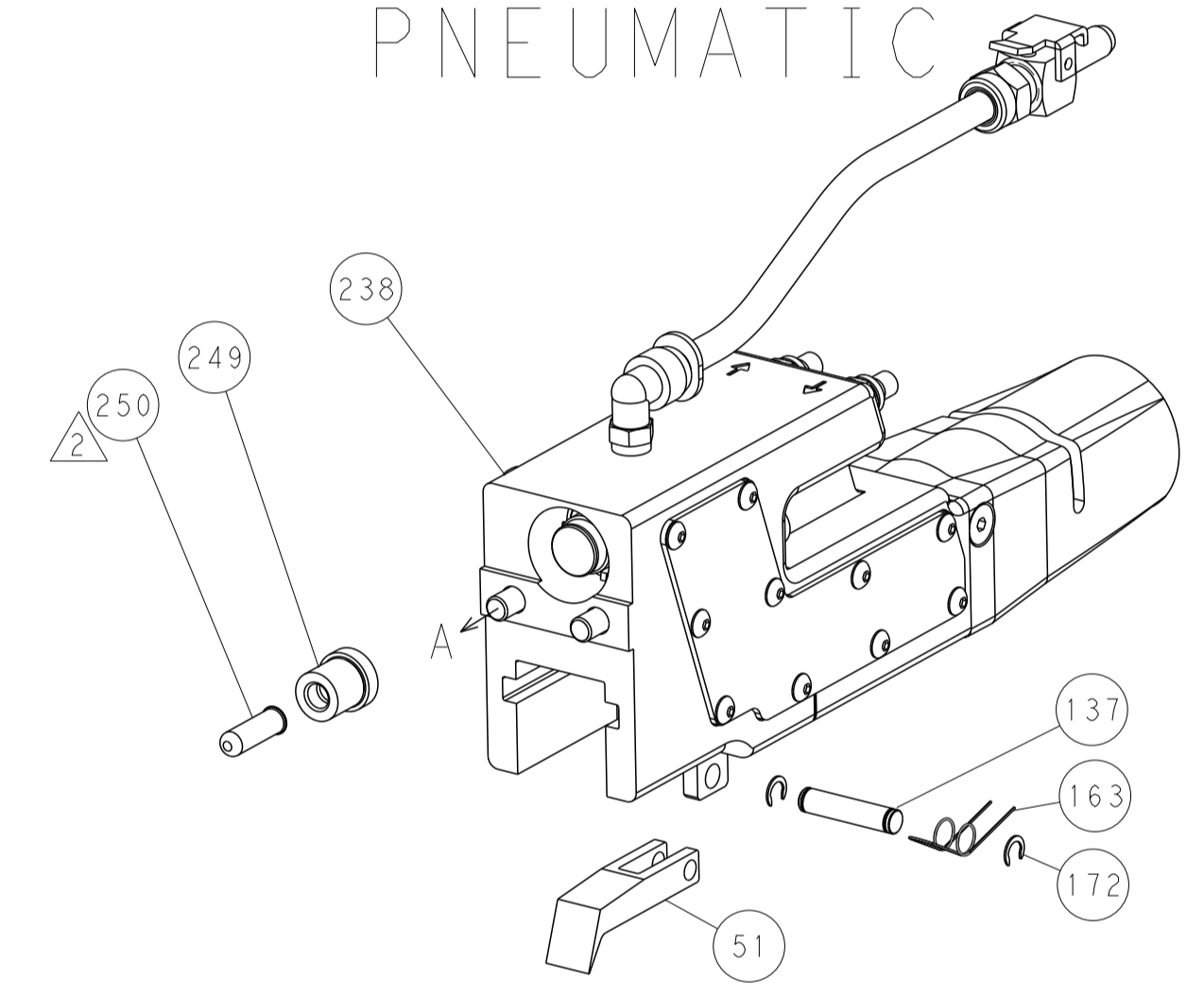

CAM POSITIONS

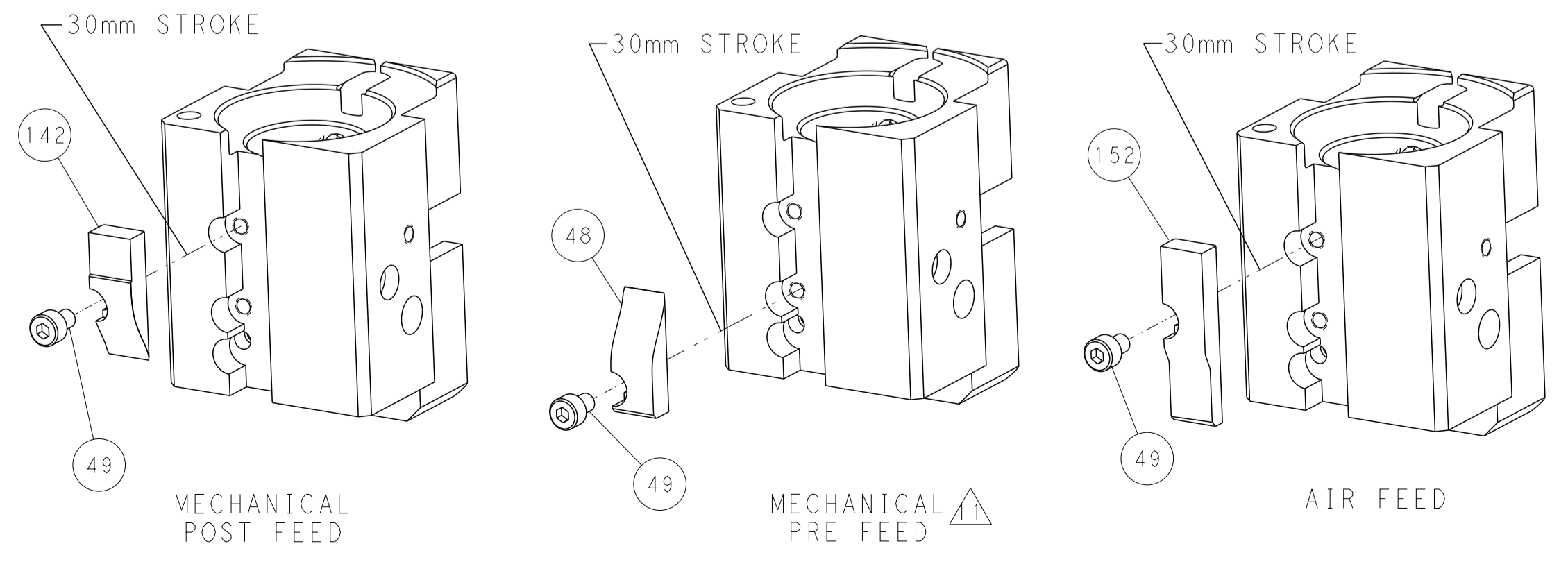

PACIFIC VERSION
 Shown on sheets 3 of 4 & 4 of 4
 (Atlantic version shown on sheets 1 of 4 & 2 of 4)

DIMENSIONS:		TOLERANCES UNLESS OTHERWISE SPECIFIED:		DWG: M. ZHAO 12MAY2016		CHK: K. ZHANG 12MAY2016		APVD: K. ZHANG 12MAY2016		NAME: Ocean End Feed Applicator	
mm	0 PLC	±		SIZE	CAGE CODE	DRAWING NO	RESTRICTED TO	STE TE Connectivity Harrisburg, PA 17105-3608			
	1 PLC	±		APPL				Customer Accessible Production Drawing			
	2 PLC	±		SCALE	1:1			SHEET 4 OF 4 REV B			
	3 PLC	±						MATERIAL			
	4 PLC	±						WEIGHT			
	ANGLES	±						Customer Accessible Production Drawing			
	FINISH							SCALE 1:1 SHEET 4 OF 4 REV B			