

PART NUMBER	REVISION	DESCRIPTION	FEED TYPE
2150324-1	C	FINE CRIMP HEIGHT ADJUST	MECHANICAL
2150324-2	C	FINE CRIMP HEIGHT ADJUST	PNEUMATIC
7-2150324-1	C	MECHANICAL AND CRIMP TOOLING KIT	MECHANICAL
7-2150324-2	C	PNEUMATIC AND CRIMP TOOLING KIT	PNEUMATIC
7-2150324-7	A	CRIMP TOOLING KIT	-

ATLANTIC VERSION TERMINATOR INTERFACE ADAPTER

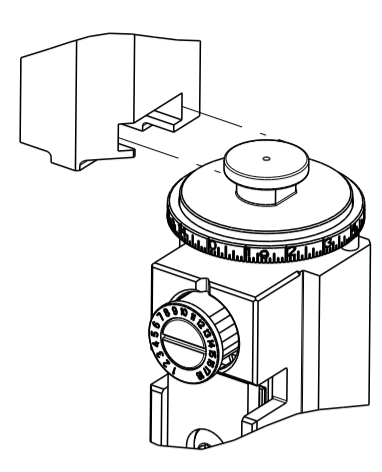

APPLICATOR DATA		
CRIMP	SIZE	TYPE
WIRE	3.05 mm [.120]	F
INSUL	3.05 mm [.120]	F
APPL INSTRUCTIONS 408-35043		

TERMINAL DATA: TE TERMINAL		TE CRIMP SPECIFICATION	
TERMINAL NAME: RECEPTACLE, FASTON, .250 SERIES			
WIRE STRIP LENGTH		INSULATION DIAMETER RANGE	
6.02-6.78 mm [.237-.267 IN]		∅1.52-2.79 mm [.060-.110 IN]	
TERMINAL APPLICATION SPECIFICATION	114-2036		
TERMINALS APPLIED			
TE TERMINAL	TE TERMINAL	TE TERMINAL	TE TERMINAL
61375-1			

WIRE SIZE	CRIMP HEIGHT mm [INCH]	CRIMP HEIGHT REFERENCE SETTING
14 AWG	1.91+/-0.05 [.075+/-0.002]	4.2
16 AWG	1.68+/-0.05 [.066+/-0.002]	7.2
18 AWG	1.55+/-0.05 [.061+/-0.002]	8.3

- 1 RECOMMENDED SPARE PARTS
- 2 REFER TO SUPPLIED INSTRUCTION SHEET FOR CLEANING, LUBRICATION AND STORAGE OF APPLICATOR.
- 3 APPLY PART NUMBER 1-23419-5 LOCTITE TO THREADS OF ITEM 180. APPLY PART NUMBER 2-23419-6 LOCTITE TO THREADS OF ITEM 242.
- 4 CRIMP HEIGHT REFERENCE SETTING WAS THE SETTING USED WHEN THE APPLICATOR WAS QUALIFIED AT THE FACTORY. ADJUSTMENT MAY BE NECESSARY WHEN RUNNING APPLICATOR IN THE FIELD.
- 5. UNLESS SPECIFIED OTHERWISE TORQUE VALUES SHALL BE USED PER DOCUMENT, 101-35000.

***WARNING**
 ON INSTALLATION, SET WIRE DISC TO CRIMP HEIGHT REFERENCE SETTING FOR LARGEST WIRE SIZE. CRIMP HEIGHT REFERENCE SETTINGS GREATER THAN THE VALUE SHOWN MAY CAUSE DAMAGE TO THE CRIMP TOOLING, REFER TO THE INSTRUCTION SHEET FOR PROPER SETUP AND ADJUSTMENTS.

LOC	DIST	REVISIONS					
A	66	P	LTN	DESCRIPTION	DATE	DWN	APVD
		A		RELEASED	24APR2013	KH	LZ
		B		ECR-18-017959	16NOV2018	FL	CT
		C		ECR-20-009076	24JUN2020	TB	RK

-	1	-	1	-	2119641-1	FEED CAM, AIR FEED	248	
-	1	1	1	1	2119082-9	CAM, SNAIL, INSULATION ADJUSTMENT	244	
-	1	1	1	1	2079764-1	WASHER, WAVE SPRING, CREST-TO-CREST	243	
3	-	1	1	1	2119083-1	RETAINER, INSULATION DIAL	242	
-	-	1	-	1	2119580-1	MECHANICAL FEED ASSEMBLY	239	
-	1	-	1	-	2844940-3	AIR FEED MODULE	238	
-	1	1	1	1	1-18028-0	WASHER, FLAT, REG M8	192	
3	-	1	1	1	1-1976055-2	STANDOFF, HOLD-DOWN	180	
-	1	1	1	1	6-993111-6	PIN, SLOTTED SPRING 3.0 X 14.0	177	
-	1	1	1	1	8-22280-7	SPRING, COMPRESSION	176	
-	1	1	1	1	1752353-2	GUIDE PIN,HOLDDOWN	175	
-	1	1	1	1	1901680-2	GUIDE PIN,HOLDDOWN	174	
-	REF	REF	REF	REF	994970-2	COUNTER, MAGNETIC	164	
-	1	1	1	1	455888-7	SPACER, CRIMPER	82	
-	1	1	1	1	2119791-5	DEPRESSOR, WIRE	73	
-	1	1	1	1	1803607-4	DOCUMENTATION PACKAGE	71	
-	2	2	2	2	2-18032-2	SCR, SET, FLT PNT, M3 X 10.0	70	
-	1	1	1	1	2119740-1	TAG, IDENTIFICATION	67	
-	2	2	2	2	2168078-1	SCREW, DRIVE, RH, RoHS, 2 x .188	66	
-	1	1	1	1	1901681-5	HOLDDOWN, TERMINAL	65	
-	2	2	2	2	2168400-8	SHCS, LOW HEAD, RoHS, M4 X 16	64	
-	1	1	1	1	2168083-2	SCR, SKT HD CAP, RoHS, M4 X 8.0	60	
-	1	1	1	1	5-18022-5	SCR, HEX HD CAP, M4 X 6.0	59	
-	-	1	-	1	2063961-1	FEED FINGER	58	
-	3	3	3	3	2168400-4	SHCS, LOW HEAD, RoHS, M4 X 8	57	
-	2	2	2	2	1-2168083-0	SCR, SKT HD CAP, RoHS, M4 X 10	56	
-	2	2	2	2	5018030-1	NUT, HEX, REG, RoHS, M3	54	
-	2	2	2	2	986965-8	NUT, LOCK, HEX, TORQUE (M4)	53	
-	1	1	1	1	1-5018030-0	NUT, HEX, REG, RoHS, M3.5	52	
-	1	-	1	-	2063961-1	FEED FINGER	51	
-	1	2	1	2	18023-9	SCR, SKT HD CAP M4 X 6.0	49	
-	-	1	-	1	2119652-1	FEED CAM, PRE FEED	48	
-	-	1	-	1	2119653-1	FEED CAM, POST FEED	47	
-	1	1	1	1	2119655-5	APPLICATOR BASIC ASSEMBLY, EF	46	
-	1	1	1	1	1803517-1	RAM ASSEMBLY, EF ATLANTIC	44	
-	1	1	1	1	1803602-1	SCR, BHSC, RoHS (M8 X 25)	41	
-	7	7	7	7	1-18028-2	WASHER, FLAT, REG M4	33	
-	2	2	2	2	2168083-9	SCR, SKT HD CAP, RoHS, M4 X 20	31	
-	2	2	2	2	2168083-2	SCR, SKT HD CAP, RoHS, M4 X 8.0	29	
-	1	1	1	1	240639-1	STRIPPER (MACHINING)	27	
-	2	2	2	2	1-2168083-5	SCR, SKT HD CAP, RoHS, M4 X 30	25	
-	1	1	1	1	1752371-1	PLATE, STRIP GUIDE	24	
-	1	1	1	1	240825-4	PLATE, STRIP HOLD DOWN	23	
-	2	2	2	2	2-22281-3	SPRING, COMPRESSION	22	
-	1	1	1	1	1803292-4	DRAG	20	
-	2	2	2	2	1901259-5	GUIDE, LOWER STRIP	18	
-	4	4	4	4	1-2079383-1	SCR, BHSC, RoHS (M6 X 12)	17	
-	1	1	1	1	1752360-1	SPACER,HOLD-DOWN	13	
1	-	1	1	1	240644-1	PLATE, REAR SHEAR	11	
-	-	-	-	-	-	-	10	
1	-	1	1	1	690482-4	PLATE, FRONT SHEAR	9	
1	2	2	1	1	1-1333224-1	ANVIL, COMBINATION (E.F. WIRE/B ONLY)	8	
1	-	1	1	1	1-2217206-0	BLADE, SLUG	7	
-	-	-	-	-	-	-	6	
-	1	1	1	1	240641-3	SPACER	5	
-	1	1	1	1	4-238011-5	BLOCK, CRIMPER SPACER	4	
1	2	2	1	1	7-2119582-2	CRIMPER, INSULATION F PREMIUM	3	
-	-	-	-	-	-	-	2	
1	2	2	1	1	456409-6	CRIMPER, WIRE .120 "F" PREMIUM	1	
-	77	72	71	-2	-1	PART NO	DESCRIPTION	ITEM NO

ATLANTIC VERSION
 Shown on sheets 1 of 4 & 2 of 4
 (Pacific version shown on sheets 3 of 4 & 4 of 4)

DIMENSIONS: mm		TOLERANCES UNLESS OTHERWISE SPECIFIED:		DWN H. HUANG 05MAR2013		CHK L. ZHANG 05MAR2013		APVD U. GUO 05MAR2013		NAME	
0 PLC ±		1 PLC ±		2 PLC ±		3 PLC ±		4 PLC ±		RESTRICTED TO	
MATERIAL		FINISH		WEIGHT		SCALE		SHEET		REV	
						A1 00779 C=2150324		1 OF 4		C	

Customer Accessible Production Drawing

LOC	DIST	REV	DESCRIPTION	DATE	OWN	APVD
A	66		SEE SHEET 1			

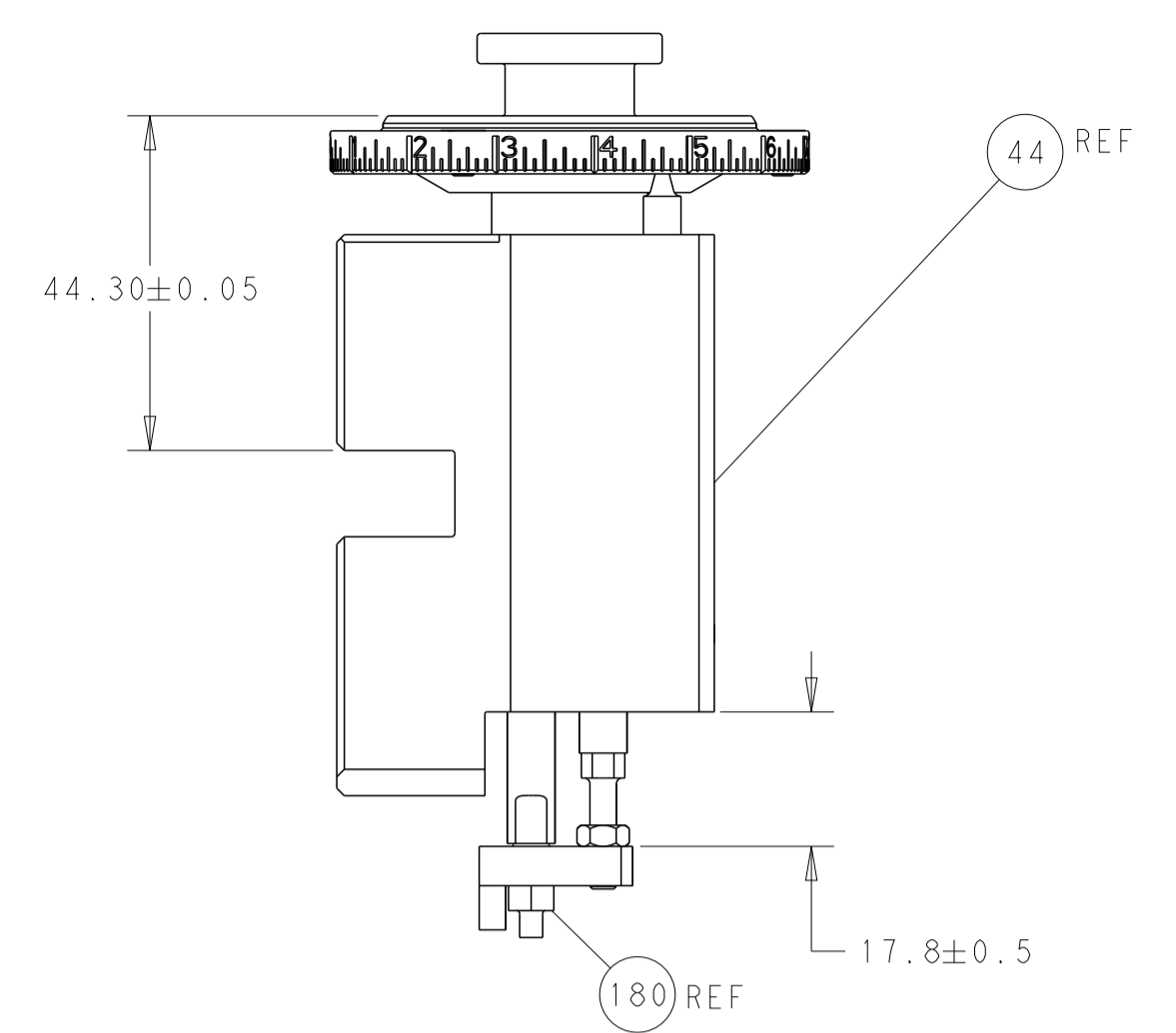

RAM AND HOLDDOWN SET-UP

FEED TYPE
MECHANICAL

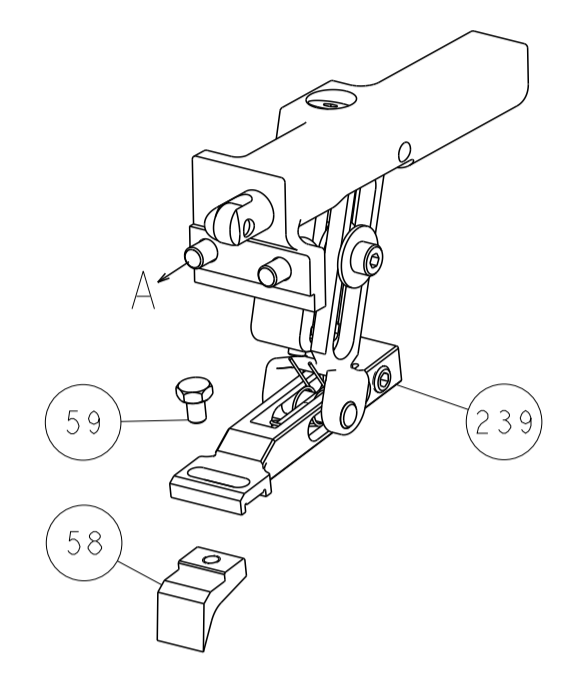

PNEUMATIC

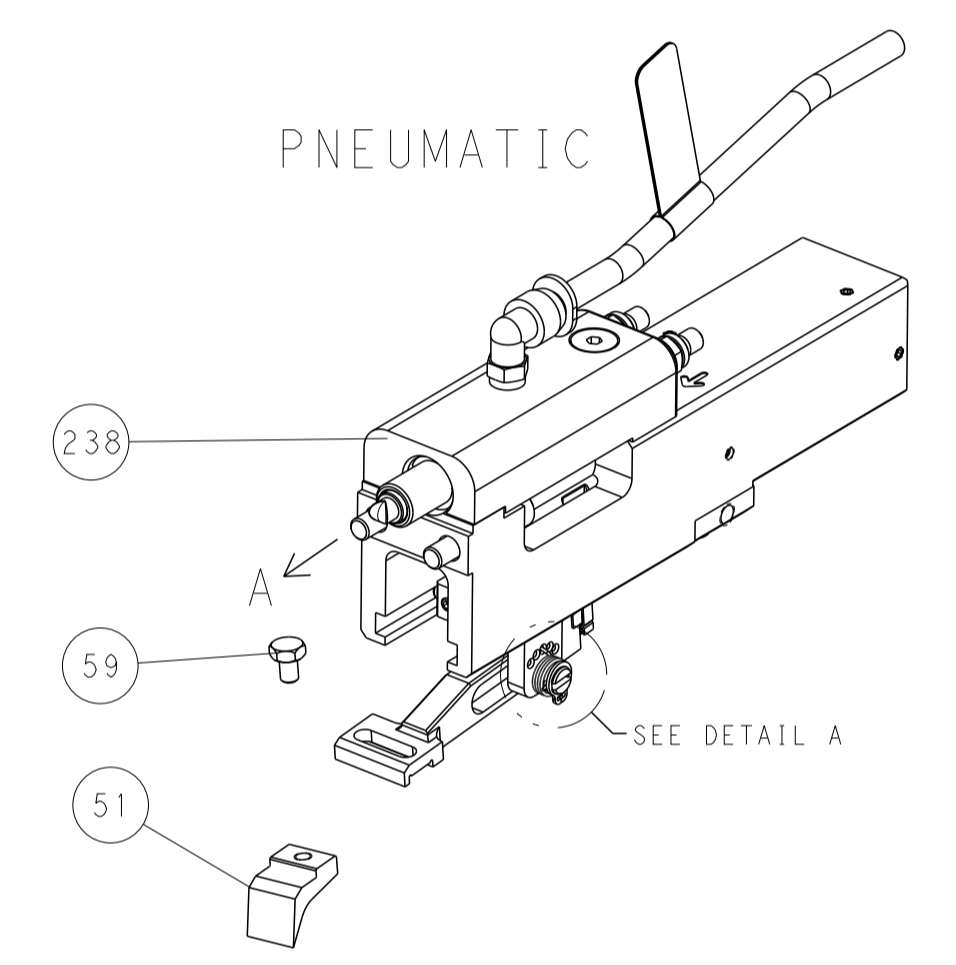

FEED SPRING
SETTING POSITION

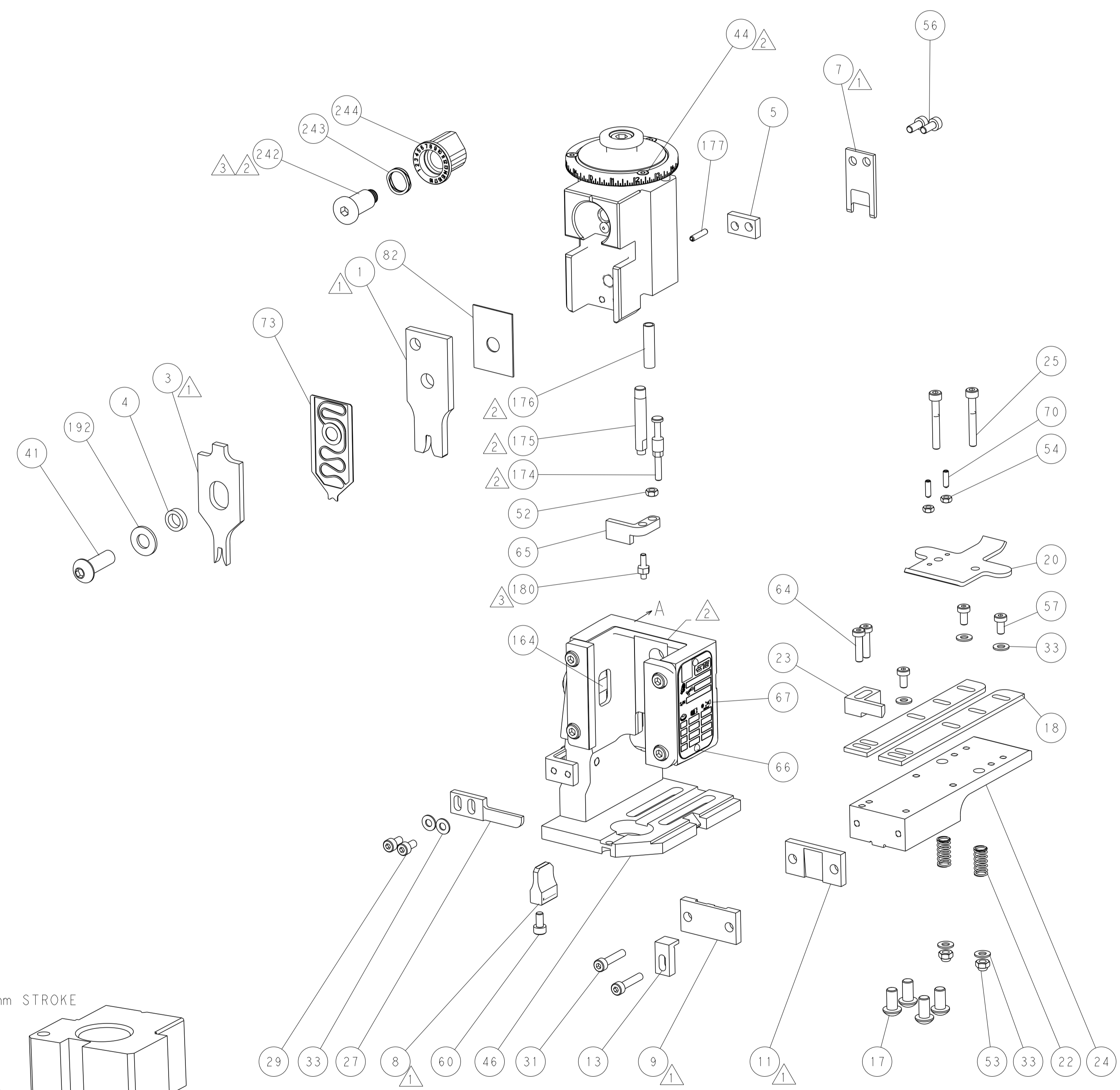
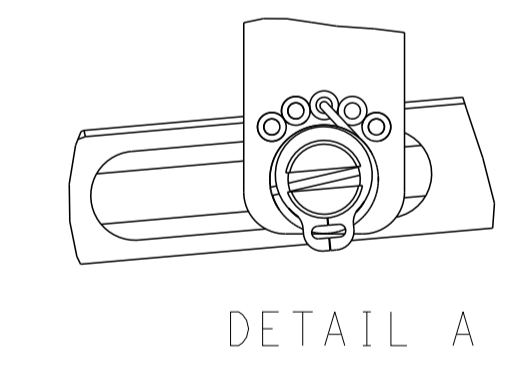

CAM POSITIONS

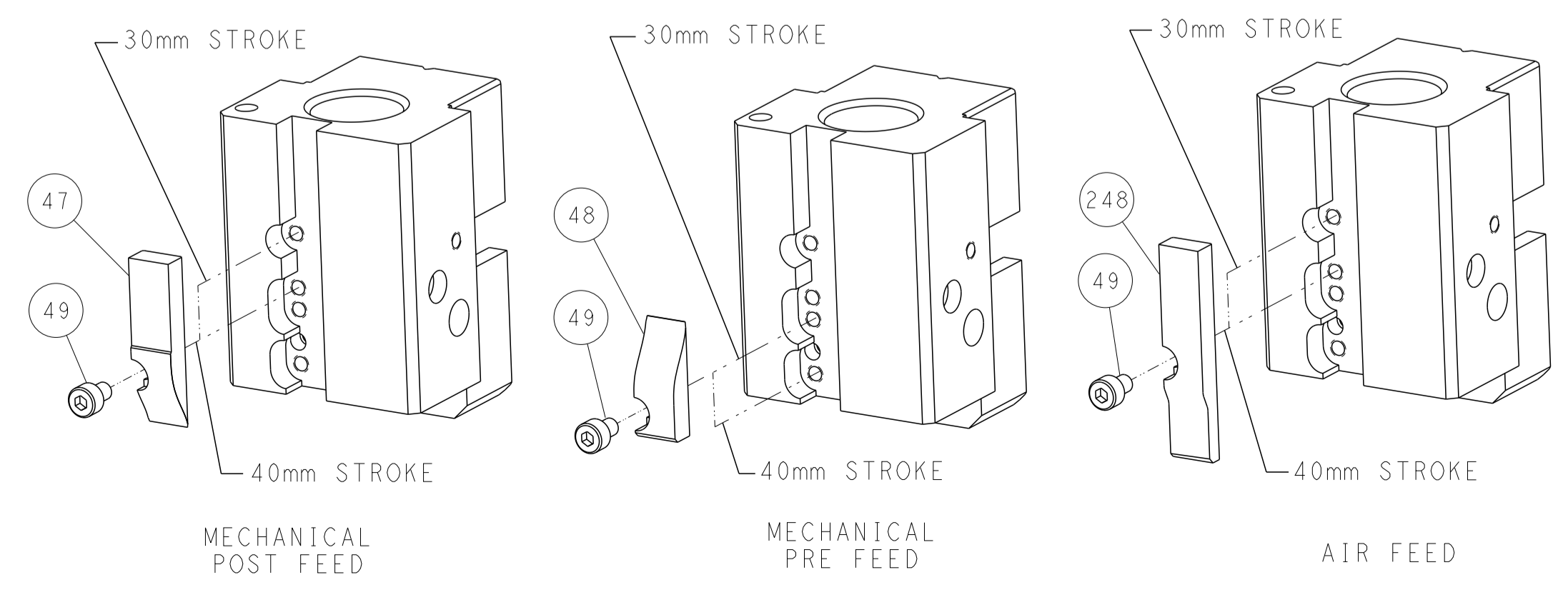

ATLANTIC VERSION
 Shown on sheets 1 of 4 & 2 of 4
 (Pacific version shown on sheets 3 of 4 & 4 of 4)

DIMENSIONS: mm 		TOLERANCES UNLESS OTHERWISE SPECIFIED: 0 PLC ± 1 PLC ± 2 PLC ± 3 PLC ± 4 PLC ± ANGLES ± FINISH		DWN K. HUANG 05MAR2013 CHK L. ZHANG 05MAR2013 APVD H. GUO 05MAR2013 PRODUCT SPEC APPLICATION SPEC WEIGHT SCALE 1:1		NAME Ocean End Feed Applicator SIZE CAGE CODE DRAWING NO. A1 00779 C=2150324 RESTRICTED TO	
Customer Accessible Production Drawing				SHEET 2 OF 4		REV C	

8	7	6	5	4	3	2	1
THIS DRAWING IS UNPUBLISHED.		RELEASED FOR PUBLICATION		20			
COPYRIGHT © BY TYCO ELECTRONICS CORPORATION. ALL RIGHTS RESERVED.							
PART NUMBER	REVISION	DESCRIPTION	FEED TYPE				
2-2150324-1	C	FINE CRIMP HEIGHT ADJUST	MECHANICAL				
2-2150324-2	C	FINE CRIMP HEIGHT ADJUST	PNEUMATIC				
7-2150324-7	A	CRIMP TOOLING KIT	-				

PACIFIC VERSION TERMINATOR
INTERFACE ADAPTER



APPLICATOR DATA		
CRIMP	SIZE	TYPE
WIRE	3.05 mm [.120]	F
INSUL	3.05 mm [.120]	F
APPL INSTRUCTIONS 408-35043		

TERMINAL DATA: TE TERMINAL		TE CRIMP SPECIFICATION	
TERMINAL NAME: RECEPTACLE, FASTON, .250 SERIES			
WIRE STRIP LENGTH 6.02-6.78 mm [.237-.267 IN]		INSULATION DIAMETER RANGE Ø1.52-2.79 mm [.060-.110 IN]	
TERMINAL APPLICATION SPECIFICATION 114-2036			
TERMINALS APPLIED			
TE TERMINAL	TE TERMINAL	TE TERMINAL	TE TERMINAL
61375-1			

WIRE SIZE	CRIMP HEIGHT mm [INCH]	CRIMP HEIGHT REFERENCE SETTING
14 AWG	1.91 +/- 0.05 [.075 +/- .002]	4.2
16 AWG	1.68 +/- 0.05 [.066 +/- .002]	7.2
18 AWG	1.55 +/- 0.05 [.061 +/- .002]	8.3



- 1 RECOMMENDED SPARE PARTS
 - 2 REFER TO SUPPLIED INSTRUCTION SHEET FOR CLEANING, LUBRICATION AND STORAGE OF APPLICATOR.
 - 3 APPLY PART NUMBER 1-23419-5 LOCTITE TO THREADS OF ITEM 180. APPLY PART NUMBER 2-23419-6 LOCTITE TO THREADS OF ITEM 242.
 - 4 CRIMP HEIGHT REFERENCE SETTING WAS THE SETTING USED WHEN THE APPLICATOR WAS QUALIFIED AT THE FACTORY. ADJUSTMENT MAY BE NECESSARY WHEN RUNNING APPLICATOR IN THE FIELD.
5. UNLESS SPECIFIED OTHERWISE TORQUE VALUES SHALL BE USED PER DOCUMENT, 101-35000.

***WARNING**
ON INSTALLATION, SET WIRE DISC TO CRIMP HEIGHT REFERENCE SETTING FOR LARGEST WIRE SIZE. CRIMP HEIGHT REFERENCE SETTINGS GREATER THAN THE VALUE SHOWN MAY CAUSE DAMAGE TO THE CRIMP TOOLING, REFER TO THE INSTRUCTION SHEET FOR PROPER SETUP AND ADJUSTMENTS.

LOC	DIST	REVISIONS					
A	66	P	LTN	DESCRIPTION	DATE	OWN	APVD
		-		SEE SHEET 1	-	-	-

	-	1	1	2119082-9	CAM, SNAIL, INSULATION ADJUSTMENT	244
	-	1	1	2079764-1	WASHER, WAVE SPRING, CREST-TO-CREST	243
3	-	1	1	2119083-1	RETAINER, INSULATION DIAL	242
	-	-	1	2119580-1	MECHANICAL FEED ASSEMBLY	239
	-	1	-	2844940-3	AIR FEED MODULE	238
	-	1	1	1-18028-0	WASHER, FLAT, REG M8	192
	-	4	4	2079383-9	SCR, BHSC, RoHS (M6 X 20)	186
3	-	1	1	1-1976055-2	STANDOFF, HOLD-DOWN	180
	-	1	1	6-993111-6	PIN, SLOTTED SPRING 3.0 X 14.0	177
	-	1	1	8-22280-7	SPRING, COMPRESSION	176
	-	1	1	1752353-2	GUIDE PIN, HOLDDOWN	175
	-	1	1	1901680-2	GUIDE PIN, HOLDDOWN	174
	-	REF	REF	994970-2	COUNTER, MAGNETIC	164
	-	1	-	2119641-2	FEED CAM, AIR FEED	152
	-	1	1	2168083-8	SCR, SKT HD CAP, RoHS, M4 X 16	144
	-	-	1	2119653-2	FEED CAM, POST FEED	142
	-	1	1	2119655-6	APPLICATOR BASIC ASSEMBLY, EF	141
	-	1	1	1803518-1	RAM ASSEMBLY, EF PACIFIC	140
	-	1	1	455888-7	SPACER, CRIMPER	82
	-	1	1	2119791-5	DEPRESSOR, WIRE	73
	-	1	1	1803607-4	DOCUMENTATION PACKAGE	71
	-	2	2	2-18032-2	SCR, SET, FLT PNT, M3 X 10.0	70
	-	1	1	2119740-1	TAG, IDENTIFICATION	67
	-	2	2	2168078-1	SCREW, DRIVE, RH, RoHS, 2 x .188	66
	-	1	1	1901681-5	HOLDDOWN, TERMINAL	65
	-	2	2	2168400-8	SHCS, LOW HEAD, RoHS, M4 X 16	64
	-	1	1	5-18022-5	SCR, HEX HD CAP, M4 X 6.0	59
	-	-	1	2063961-1	FEED FINGER	58
	-	3	3	2168400-4	SHCS, LOW HEAD, RoHS, M4 X 8	57
	-	2	2	1-2168083-0	SCR, SKT HD CAP, RoHS, M4 X 10	56
	-	2	2	5018030-1	NUT, HEX, REG, RoHS, M3	54
	-	2	2	986965-8	NUT, LOCK, HEX, TORQUE (M4)	53
	-	1	1	1-5018030-0	NUT, HEX, REG, RoHS, M3.5	52
	-	1	-	2063961-1	FEED FINGER	51
	-	1	2	18023-9	SCR, SKT HD CAP M4 X 6.0	49
	-	-	1	2119652-1	FEED CAM, PRE FEED	48
	-	1	1	1803602-1	SCR, BHSC, RoHS (M8 X 25)	41
	-	7	7	1-18028-2	WASHER, FLAT, REG M4	33
	-	2	2	2168083-9	SCR, SKT HD CAP, RoHS, M4 X 20	31
	-	2	2	2168083-2	SCR, SKT HD CAP, RoHS, M4 X 8.0	29
	-	1	1	240639-1	STRIPPER (MACHINING)	27
	-	2	2	1-2168083-5	SCR, SKT HD CAP, RoHS, M4 X 30	25
	-	1	1	1752371-1	PLATE, STRIP GUIDE	24
	-	1	1	240825-4	PLATE, STRIP HOLD DOWN	23
	-	2	2	2-22281-3	SPRING, COMPRESSION	22
	-	1	1	1803292-4	DRAG	20
	-	2	2	1901259-5	GUIDE, LOWER STRIP	18
	-	1	1	1752360-1	SPACER, HOLD-DOWN	13
1	-	1	1	240644-1	PLATE, REAR SHEAR	11
	-	-	-	-	-	10
	-	1	1	690482-4	PLATE, FRONT SHEAR	9
1	1	1	1	1-1333224-1	ANVIL, COMBINATION (E.F. WIRE/B ONLY)	8
1	-	1	1	1-2217206-0	BLADE, SLUG	7
	-	-	-	-	-	6
	-	1	1	240641-3	SPACER	5
	-	1	1	4-238011-5	BLOCK, CRIMPER SPACER	4
1	1	1	1	7-2119582-2	CRIMPER, INSULATION F PREMIUM	3
	-	-	-	-	-	2
1	1	1	1	456409-6	CRIMPER, WIRE .120 "F" PREMIUM	1
	-	77	22	21	PART NO	ITEM NO

PACIFIC VERSION
Shown on sheets 3 of 4 & 4 of 4
(Atlantic version shown on sheets 1 of 4 & 2 of 4)

DIMENSIONS: mm		TOLERANCES UNLESS OTHERWISE SPECIFIED:		DWG R. HUANG 05MAR2013		CHK L. ZHANG 05MAR2013		NAME Ocean End Feed Applicator	
0 PLC ±		1 PLC ±		APVD J. GUO 05MAR2013		PRODUCT SPEC		SIZE A1	
2 PLC ±		3 PLC ±		APPLICATION SPEC		CAGE CODE		DRAWING NO 00779	
4 PLC ±		ANGLES ±		WEIGHT		SCALE 1:1		SHEET 3 OF 4	
FINISH		MATERIAL		CUSTOMER ACCESSIBLE PRODUCTION DRAWING		REV C		REV	

LOC	DIST	REV	DATE	BY	APPV
A	66				

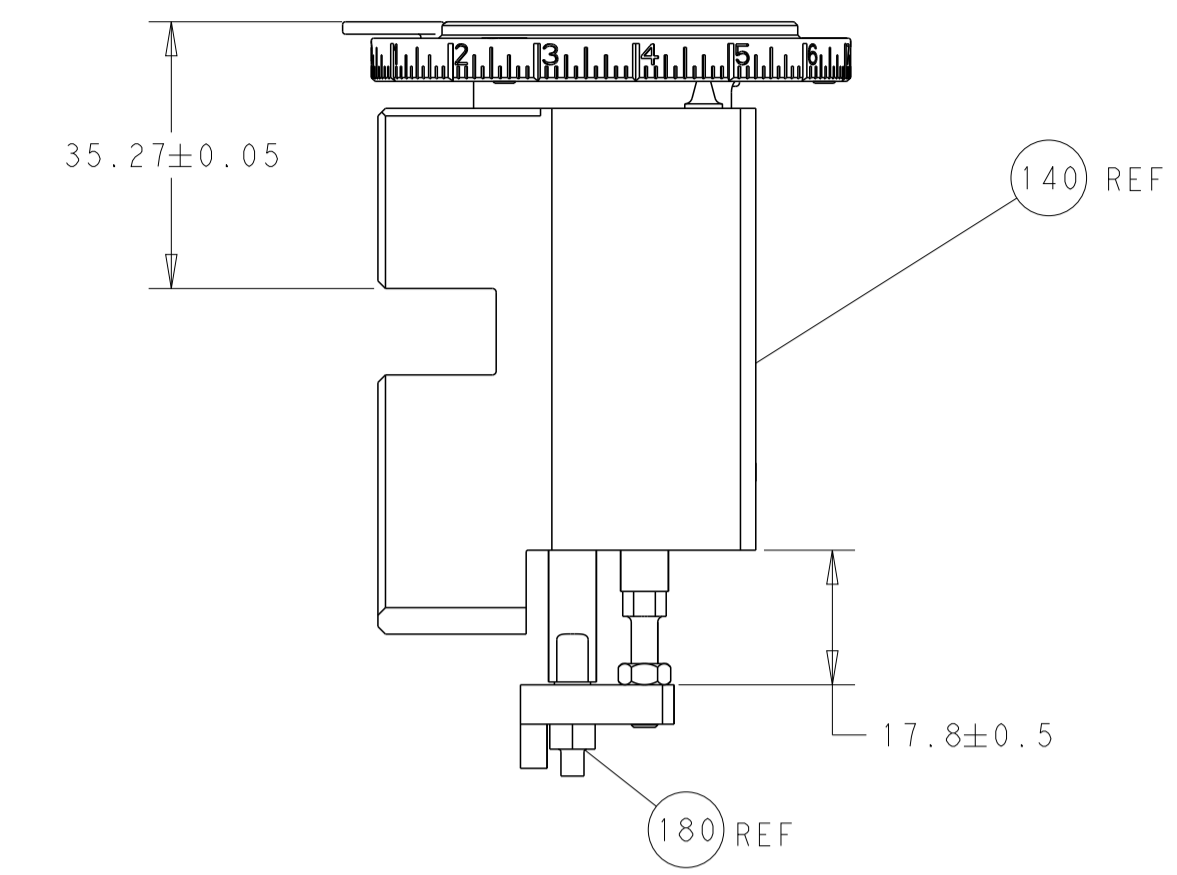

RAM AND HOLDDOWN SET-UP

FEED TYPE
MECHANICAL

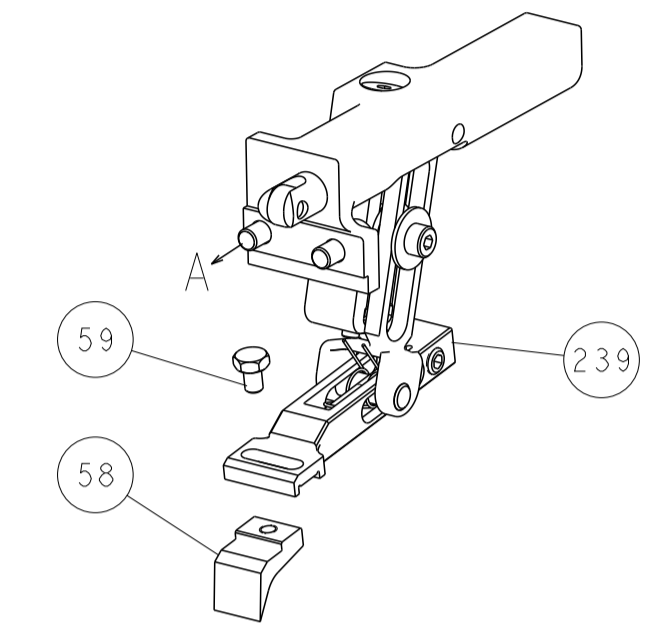

PNEUMATIC

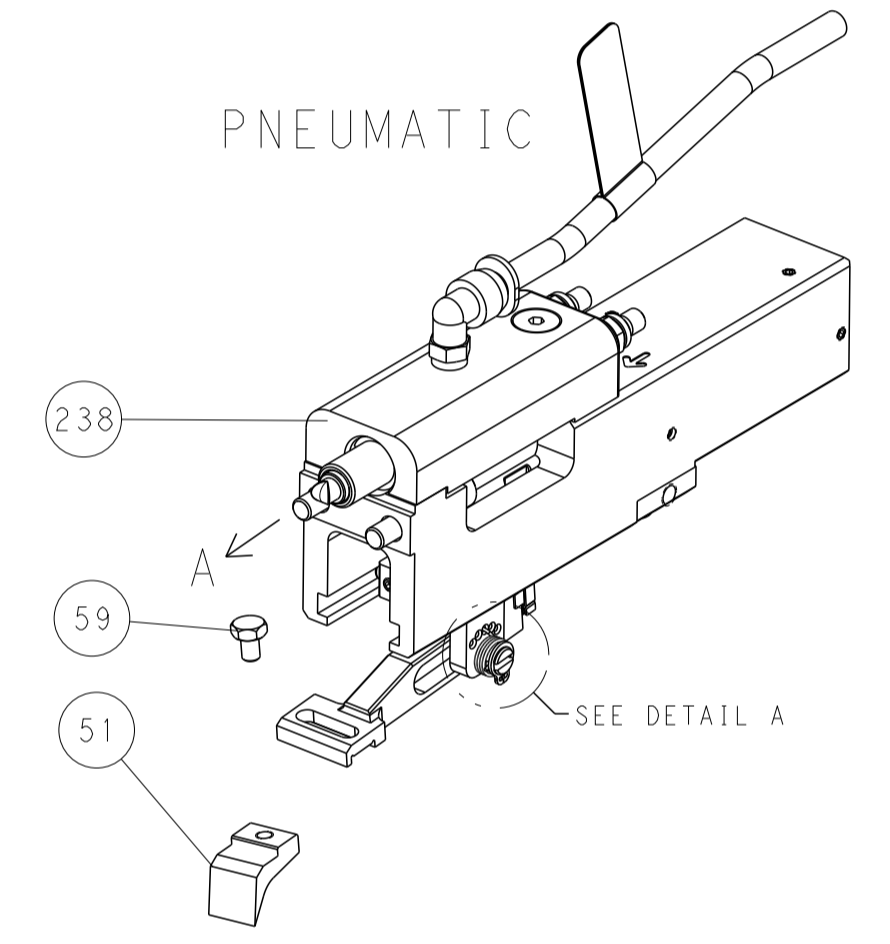

FEED SPRING
SETTING POSITION

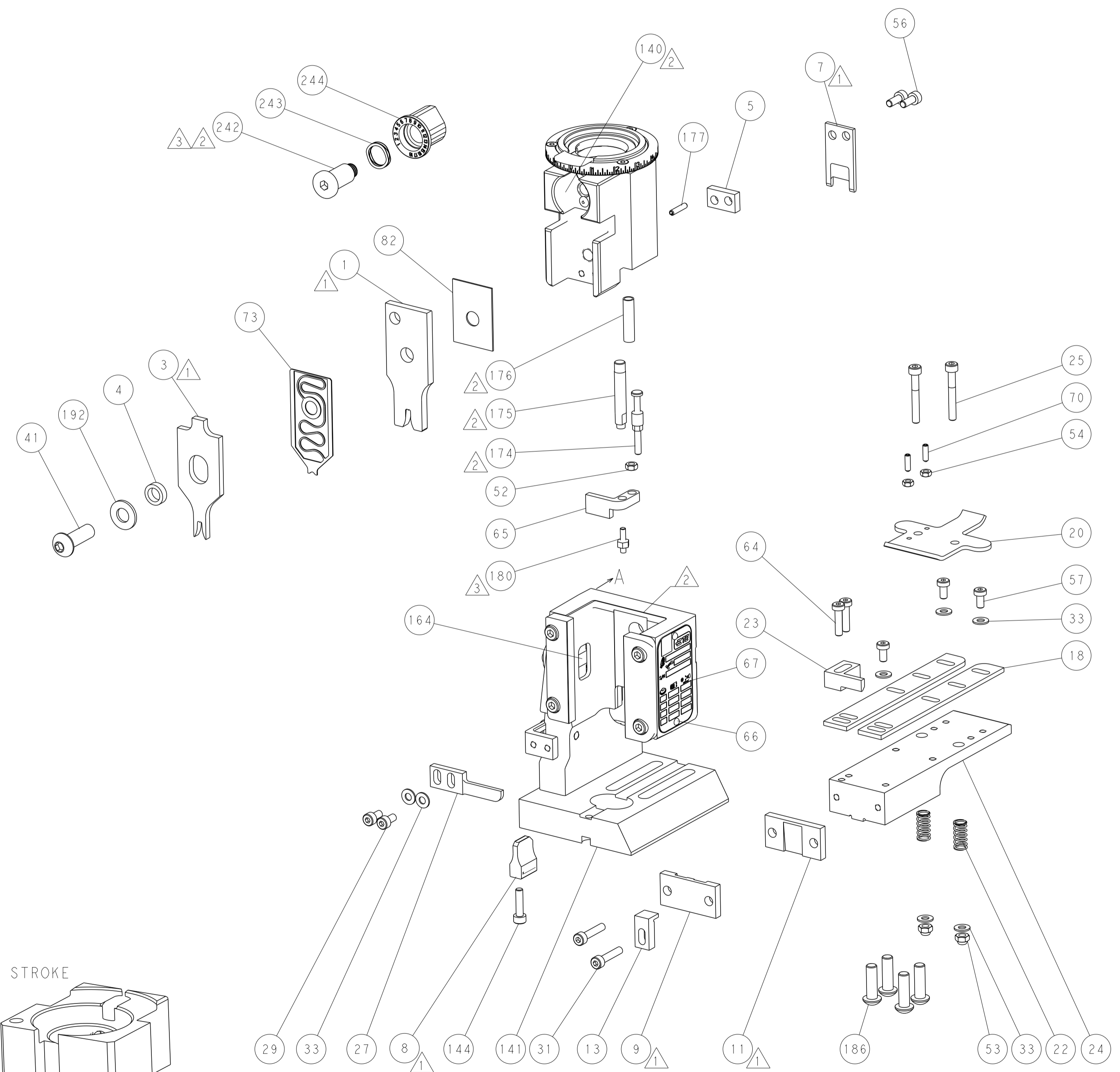
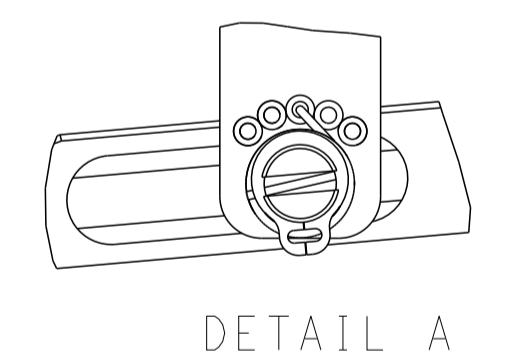

CAM POSITIONS

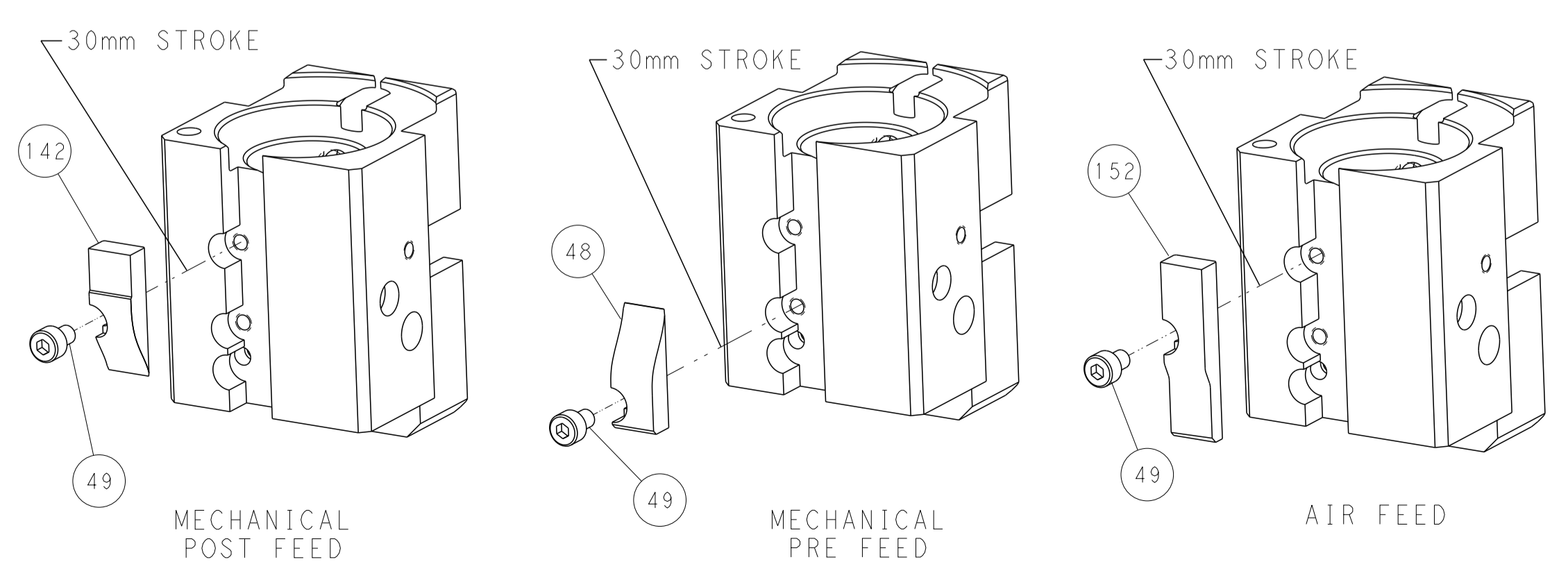

PACIFIC VERSION
 Shown on sheets 3 of 4 & 4 of 4
 (Atlantic version shown on sheets 1 of 4 & 2 of 4)

<small>THIS DRAWING IS UNPUBLISHED. RELEASED FOR PUBLICATION BY TYCO ELECTRONICS CORPORATION. ALL RIGHTS RESERVED.</small> <small>THIS DRAWING IS UNPUBLISHED. RELEASED FOR PUBLICATION BY TYCO ELECTRONICS CORPORATION. ALL RIGHTS RESERVED.</small>		DWN K. HUANG 05MAR2013 CHK L. ZHANG 05MAR2013 APVD J. GUO 05MAR2013	NAME Ocean End Feed Applier
DIMENSIONS: mm 	TOLERANCES UNLESS OTHERWISE SPECIFIED: 0 PLC ± 1 PLC ± 2 PLC ± 3 PLC ± 4 PLC ± ANGLES ± FINISH	PRODUCT SPEC APPLICATION SPEC WEIGHT SCALE 1:1	SIZE CAGE CODE DRAWING NO A1 00779 C-2150324 SHEET 4 OF 4 REV C