Qualification Test Of PDL New Receptacle Contact

1. INTRODUCTION

1.1 Purpose

Testing was performed on the new PDL receptacle contact for the new part qualification.
Contact P/N: 2232902-1, wire size: 26~22 AWG.

1.2 Scope

This report covers the electrical, mechanical and environmental performance of the PDL connector. Test was performed at TE Shanghai Electrical Test Laboratory per Product Specification 108-5410. The associated test number is TP-15-03141.

1.3 Conclusion

The PDL contact listed in paragraph 1.4 met all the listed requirements in Section 3 Summary of Testing.
The contact can meet all the electrical, mechanical and environmental performance requirements of Product Specification 108-5410, Revision H.

1.4 Test Specimens

Specimens with the following part numbers were used for test:

Description	P/N	Part Revision
PDL Receptacle Contact	2232902-1	1
PDL Plug Housing	177898-1	S
PDL TAB Contact	177916-1	H
PDL Cap Housing	179463-1	U

1.5 Test Sequence

Test Item	Test Group ^{a)}											
	1	2	3	4	5	6	7	8	9	10	11	12
	Test Sequence ^{b)}											
Examination of Product	1,3	1	1	1,7	1,7	1,5	1,4	1,4	1,4	1,4	1,4	1,4
Low Level Contact Resistance				2,4,6	3,6	2,4	2,5	2,5	2,5	2,5	2,5	2,5
Insulation Resistance							6					
Withstanding Voltage							7					
Mechanical Shock				3								
Vibration				5								
Connector Mating Force					2							
Connector Unmating Force					4							
Crimp Tensile Strength	2											
Durability					5							
Contact Insertion Force		2										
Contact Retention Force			2									
Humidity-Temperature Cycling							3					
H2S Gas											3	
Ammonia												3
Thermal Shock						3						
Salt Spray								3				
Resistance to Cold										3		
Heat Aging									3			

Note: a). Test group defined per requirement.
 b). Numbers indicate sequence in which tests are performed

1.6 Environmental Conditions

Unless otherwise stated, the following environmental conditions prevailed during testing:

Temperature: 15°C to 35°C
 Relative Humidity: 25% to 75%

2. TEST PROCEDUES

2.1 Examination of Product

Visual Inspection: appearance, and function of specimens pursuant to the applicable inspection plan.
 Requirements: Meets requirements of product drawing and no physical damage.
 Test Method: EIA-364-18B.

2.2 Low Level Contact Resistance

Subject mated contacts assembled in housing to 20 millivolt maximum open circuit at 10 milliamperes maximum.
 Requirements: 10 milliohms maximum initial, 10 milliohms maximum final.
 Test Method: EIA 364-23C

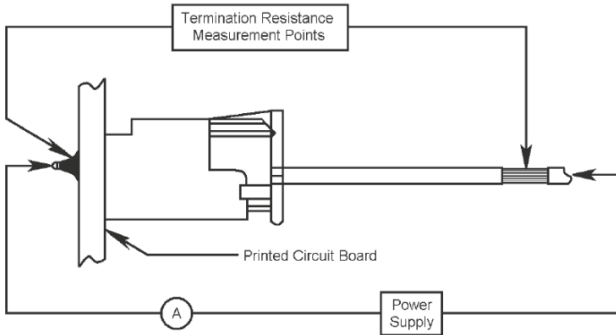

Fig.1 LLCR Measurement Points (Subtract Wire Bulk)

2.3 Crimp Tensile Strength

Apply an axial pull-off load to crimped wire of contact secured on the tester.
 Operation Speed: 100 mm/min. Subject take insulation barrel away.
 Requirements: 49N min. for 22AWG, 29.4N min. for 24AWG, 19.6N min. for 26AWG.

2.4 Mating force & un-mating force

Measure force necessary to mate & un-mate connector assembly with locking latches disengaged. Mount connector in fixtures and perform test at 100 mm per minute.
 Requirements: Mating force: 6.86N maximum per contact, total 13.72N Max.
 Un-mating force: 1.47 minimum per contact, total 2.94N Min.
 Test Method: EIA 364-13B

2.5 Contact retention force

Apply an axial pull-off load to crimped wire.
 Requirements: 41.16N min.

2.6 Contact insertion force

Measure the force required to insert contact into housing.
 Requirements: 6.86N max.

2.7 Insulation Resistance

Insulation resistance was measured separately between the closest adjacent contacts at 500Vdc for 1 minute.
 Requirements: 1000M Ω Min. Initial, 500M Ω Min. Final.
 Test Method: EIA-364-21 D

2.8 Dielectric Withstanding Voltage

Test between adjacent contacts of mated connector assemblies. 2.2 kilovolts AC dielectric withstanding voltage, 1 minute hold.
 Requirements: No breakdown, no flashover
 Test Method: EIA-364-20 D

2.9 Mechanical Shock

Mated Conn. (50 G), Halfsign Curve, durations: 11 m sec, 3 drops each to normal and reversed directions of X,Y,Z axes, totally 18 drops.

Requirements: No electrical discontinuity greater than 1 μ sec. shall occur.

2.10 Vibration

Subjected mated connectors to 10-55-10 Hz traversed in 1 minute at 1.52mm amplitude 2 hours each of 3 mutually perpendicular planes. 100 mA applied.

Requirements: No electrical discontinuity greater than 1 μ sec. shall occur.

2.11 Durability

25 cycles repeated mate/unmating.

Requirements: No physical damage.

2.12 Humidity-Temperature Cycling

Mated connectors, 25~65° C, 80~98% R.H. 10 cycles.

Requirements: No physical damage.

2.13 H2S Gas

Mated connectors, 3 \pm 1 ppm, 40 \pm 2° C 96 hours.

Requirements: No physical damage, no corrosion influence performance.

2.14 Ammonia

Mated connectors, put into atmosphere that rated 25 ml/l of 3% NH₃ for 7 hours.

Requirements: No physical damage, no corrosion influence performance.

2.15 Thermal Shock

Mated connectors, -55° C /30min., 85° C /30min. repeat 25 cycles.

Requirements: No physical damage.

2.16 Salt Spray

Mated connectors, 5 \pm 1 % salt concentration for 48 hours.

Requirements: No physical damage, no corrosion influence performance.

2.17 Resistance to Cold

Mated connectors, -30° C \pm 2° C , 96 hours.

Requirements: No physical damage.

2.18 Heat Aging

Mated connectors, 105° C \pm 2° C , 96 hours.

Requirements: No physical damage.

3. SUMMARY OF TESTING

Group	Test Item	N	Condition	Test Result				Requirement	Conclusion	
				Max	Min	Ave	Unit			
1	Examination of Product	3	initial	No physical damage occurred.				/	No abnormalities	Meet Spec
	Crimp Tensile Strength(22A WG)	3	initial	78.78	63.03	71.22	N	49N Min.	Meet Spec	
	Crimp Tensile Strength(24A WG)	3	initial	47.53	45.44	46.18	N	29.4N Min.	Meet Spec	
	Crimp Tensile Strength(26A WG)	3	initial	29.31	21.95	26.23	N	19.6N Min.	Meet Spec	
	Examination of Product	3	final	No physical damage occurred.				/	No abnormalities	Meet Spec
2	Examination of Product	3	initial	No physical damage occurred.				/	No abnormalities	Meet Spec
	Contact Insertion Force	3	initial	5.1	3.94	4.53	N	6.86N Max.	Meet Spec	
3	Examination of Product	3	initial	No physical damage occurred.				/	No abnormalities	Meet Spec
	Contact Retention Force	3	initial	55.47	43.67	51.09	N	41.16N Min.	Meet Spec	
4	Examination of Product	3	initial	No physical damage occurred.				/	No abnormalities	Meet Spec
	LLCR	3	initial	3.07	2	2.3	mΩ	10mΩ Max.	Meet Spec	
	Mechanical Shock	3	initial	No physical damage occurred, No electrical discontinuity greater than 1μs.				mΩ	No abnormalities	Meet Spec
	LLCR	3	initial	3.29	2.06	2.47	mΩ	10mΩ Max.	Meet Spec	
	Vibration	3	initial	No physical damage occurred, No electrical discontinuity greater				mΩ	No abnormalities	Meet Spec
	LLCR	3	final	3.35	2.11	2.47	mΩ	20mΩ Max.	Meet Spec	
	Examination of Product	3	final	No physical damage occurred.				/	No abnormalities	Meet Spec
5	Examination of Product	3	initial	No physical damage occurred.				/	No abnormalities	Meet Spec
	Mating Force	3	initial	13.48	11.52	12.37	N	13.72N Max.	Meet Spec	
	LLCR	3	initial	2.59	1.79	2.15	mΩ	No abnormalities	Meet Spec	
	Un-mating Force	3	initial	13.02	10.22	11.5	N	2.94N Min.	Meet Spec	
	Durability	3	initial	No physical damage occurred.				mΩ	No abnormalities	Meet Spec
	LLCR	3	final	2.94	1.91	2.35	mΩ	20mΩ Max.	Meet Spec	
	Examination of Product	3	final	No physical damage occurred.				/	No abnormalities	Meet Spec

Group	Test Item	N	Condition	Test Result				Requirement	Conclusion
				Max	Min	Ave	Unit		
6	Examination of Product	3	initial	No physical damage occurred.				No abnormalities	Meet Spec
	LLCR	3	initial	2.68	2.23	2.46	mΩ	10mΩ Max.	Meet Spec
	Thermal Shock	3	initial	No physical damage occurred.				No abnormalities	Meet Spec
	LLCR	3	final	2.47	1.85	2.17	mΩ	20mΩ Max.	Meet Spec
	Examination of Product	3	final	No physical damage occurred.				No abnormalities	Meet Spec
7	Examination of Product	3	initial	No physical damage occurred.				No abnormalities	Meet Spec
	LLCR	3	initial	2.73	1.92	2.35	mΩ	10mΩ Max.	Meet Spec
	Humidity and Temperature Cycling	3	initial	No physical damage occurred				No abnormalities	Meet Spec
	Examination of Product	3	final	No physical damage occurred.				No abnormalities	Meet Spec
	LLCR	3	final	3.91	2.7	3.3	mΩ	20mΩ Max.	Meet Spec
	Insulation Resistance	3	initial	17.08	2.01	7.84	10 ¹¹ Ω	500MΩ Min.	Meet Spec
	Withstanding Voltage	3	initial	No flashover or breakdown of voltage				No abnormalities	Meet Spec
8	Examination of Product	3	initial	No physical damage occurred.				No abnormalities	Meet Spec
	LLCR	3	initial	2.87	2.33	2.58	mΩ	10mΩ Max.	Meet Spec
	Salt Spray	3	initial	No physical damage, no corrosion influence performance.				No abnormalities	Meet Spec
	Examination of Product	3	final	No physical damage occurred.				No abnormalities	Meet Spec
	LLCR	3	final	2.61	1.96	2.18	mΩ	20mΩ Max.	Meet Spec
9	Examination of Product	3	initial	No physical damage occurred.				No abnormalities	Meet Spec
	LLCR	3	initial	2.71	2.04	2.47	mΩ	10mΩ Max.	Meet Spec
	Heat Aging	3	initial	No physical damage occurred.				No abnormalities	Meet Spec
	Examination of Product	3	final	No physical damage occurred.				No abnormalities	Meet Spec
	LLCR	3	final	4.34	2.83	3.81	mΩ	20mΩ Max.	Meet Spec

Group	Test Item	N	Condition	Test Result				Requirement	Conclusion	
				Max	Min	Ave	Unit			
10	Examination of Product	3	initial	No physical damage occurred.				/	No abnormalities	Meet Spec
	LLCR	3	initial	4.21	1.56	2.47	mΩ	10mΩ Max.	Meet Spec	
	Resistance To Cold	3	initial	No physical damage occurred.				mΩ	No abnormalities	Meet Spec
	Examination of Product	3	final	No physical damage occurred.				/	No abnormalities	Meet Spec
	LLCR	3	final	5.85	5.08	5.55	mΩ	20mΩ Max.	Meet Spec	
11	Examination of Product	3	initial	No physical damage occurred.				/	No abnormalities	Meet Spec
	LLCR	3	initial	2.64	1.77	2.1	mΩ	10mΩ Max.	Meet Spec	
	H2S Gas	3	initial	No physical damage occurred.				mΩ	No abnormalities	Meet Spec
	Examination of Product	3	final	No physical damage occurred.				/	No abnormalities	Meet Spec
	LLCR	3	final	2.98	2.22	2.48	mΩ	20mΩ Max.	Meet Spec	
12	Examination of Product	3	initial	No physical damage occurred.				/	No abnormalities	Meet Spec
	LLCR	3	initial	3.24	2.65	3.02	mΩ	10mΩ Max.	Meet Spec	
	Ammonia	3	initial	No physical damage occurred.				mΩ	No abnormalities	Meet Spec
	Examination of Product	3	final	No physical damage occurred.				/	No abnormalities	Meet Spec
	LLCR	3	final	3.75	3.23	3.49	mΩ	20mΩ Max.	Meet Spec	

Note: 10¹¹Ω=100GΩ, 1GΩ =1000MΩ.

The contact can meet all the electrical, mechanical and environmental performance requirements.