



A LOOK INSIDE A SMART ELECTRIC METER

The smart grid is more than just power generation and distribution; it's an ecosystem of Internet of Things (IoT) connected technologies and communication networks that can allow for two-way communications transmitting data that can be analyzed to assess grid stability, prevent and automatically report outages, monitor advanced digital readouts that can give consumers better information, and more. Smart meters are an essential part of today's smart grid.

What makes smart meters smart? What components are inside? What key connection components are needed? To answer these questions, we disassembled two smart meters. Let's take a look:

Appearance and Key Specifications

The meters are respectively produced by Landis+Gyr (left) and Linyang (right), a local brand in Jiangsu Province. They are similar in terms of external appearance, functions and internal structure, while the Linyang-made smart meter has an additional feature – wireless communication. As such, it houses an additional communication module inside.



EXTERNAL VIEW OF LANDIS+GYR (LEFT) AND LINYANG (RIGHT)

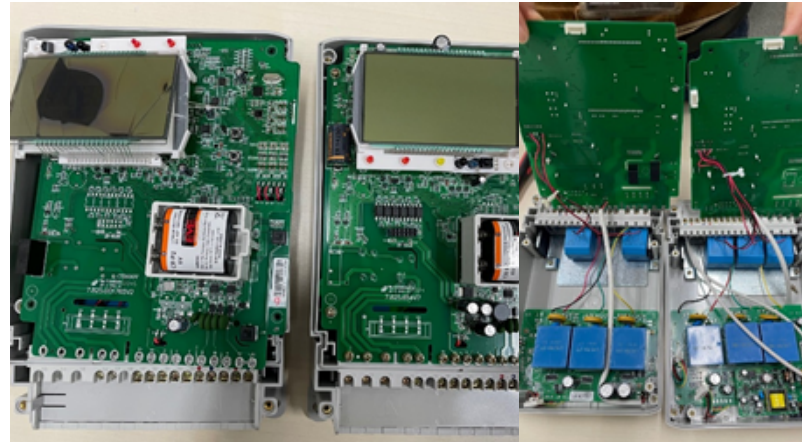

INNER STRUCTURE

Basic specifications and functions

Model	Landis+Gyr DTZ1169	Linyang DSZY71-G
Basic Specifications	Three-phase Four-wire, 50Hz, 3×57.7/100V	Three-phase Three-wire, 50Hz, 3×100V
Communication	RS485, Infrared (standard)	RS485, Infrared (standard), Wireless (GPRS/CDMA)
Basic Functions	Electric power measurement, demand measurement, display function, clock, duration and charge-rate functions, timer function, measurement and monitoring, time records, freezing function, load record, power-interruption for meter reading, pulse output	Electric power measurement, remote charge-control, display function, clock, duration and charge-rate functions, timer function, measurement and monitoring, incident recording, freezing function, power-interruption for meter reading, data storage, reset to zero, communication, pulse output, load control, parameters setting and safety verification, etc.
Dimension (mm)	290×170×85	290×170×85
Number of Board	2	3

Let's now examine the internal structure of the Jiangsu Linyang meter.

Overall Design

The meter has a square, box-like shape. The upper cover is screwed to the bottom, and its sealing structure can prevent unauthorized individuals to remove the cover and access the meter's interior.



THE OUTER COVER OF JIANGSU LINYANG METER

After the outer case is removed, we can see the main body consists of 3 boards. The first is the communication module for wireless communication. The second section is the main board for installation display, microcontroller unit (MCU) and two batteries. It is likely responsible for display, data processing, storage and power-supply of the meter. The main board is connected through wire-to-board interconnect to the third board, a power board. The latter is believed to be responsible for system power-supply, voltage stabilization and circuit regulation.

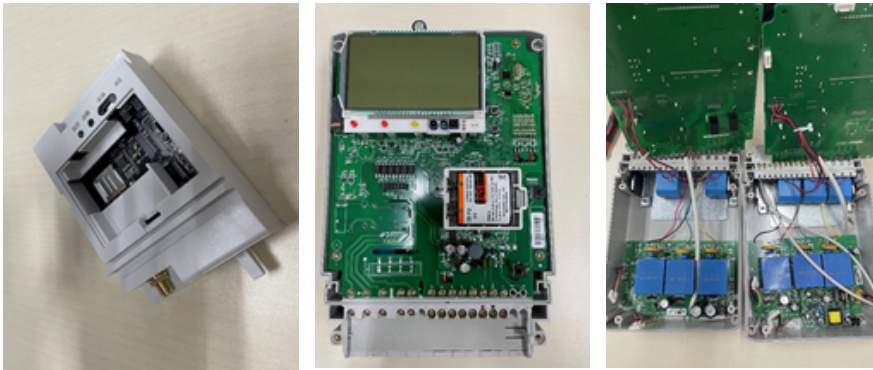

COMMUNICATION MODULE (LEFT), MAIN BOARD (MIDDLE), POWER BOARD (RIGHT)

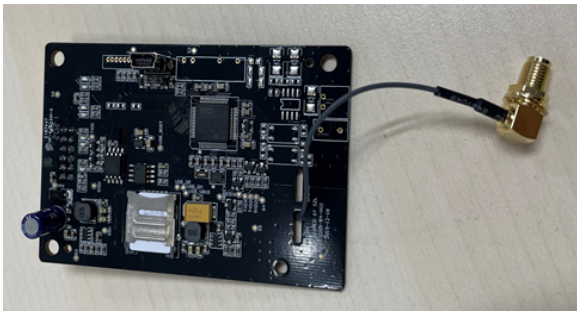

COMMUNICATION BOARD

Communication module

The meter has a built-in General Packet Radio Service (GPRS) module that allows it to be directly connected to the meter-reading system. With its modular design, it appears to be pluggable and interchangeable. The main board has two chips: one is a flash chip model number MX25L25645G from Macronix, and the other is a 32F205 series microcontroller manufactured by STMicroelectronics based on ARM structure. Other components include a SIM memory card, USB port, power supply, and antenna.

Wireless and connector products include a micro SIM card connector, RF connector, board-to-board connector, and external antenna.

Mainboard

We can see that on the mainboard a display unit that is welded onto the circuit board. Beneath the display unit is the MCU. The chip installed is STM32 chip manufactured by STMicroelectronics, that can be used for high-performance, low-cost and low power-consumption embedded applications. Voltage and current samples are converted using the measurement chip into output digital data (electric pulse) for actual electric power.



MAIN BOARD

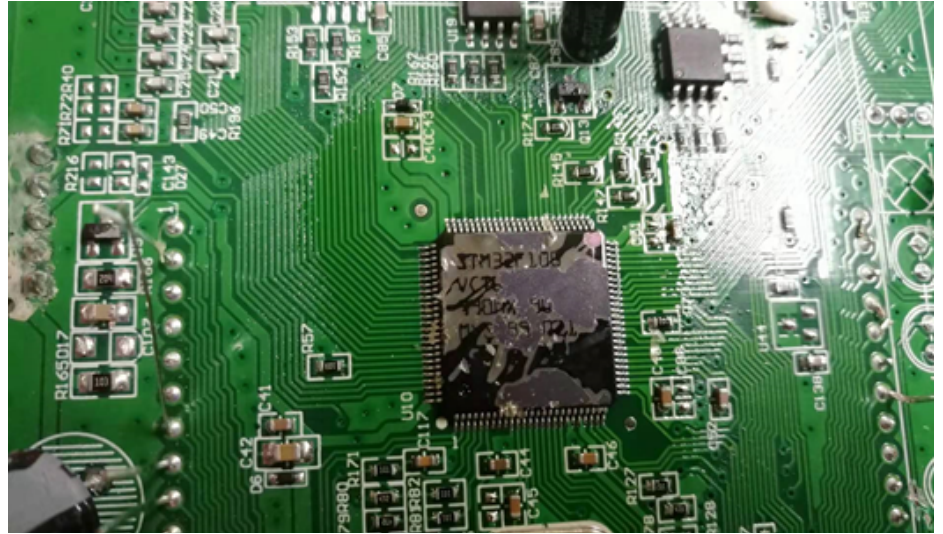

MCU

A 3.6V lithium-ion battery serves as back-up battery, and a 6V EVE lithium-ion battery supports power-interruption during meter-reading.

Connector products can include wire-to-board connectors, passive components and resistors.

Power board

There are 3 transformers and an intermediate-frequency transformer on the power board. These are typically intended to stabilize voltage and regulate circuits. There are also several resistors/capacitors for regulating the circuit. The connector products included are mainly wire-to-board.

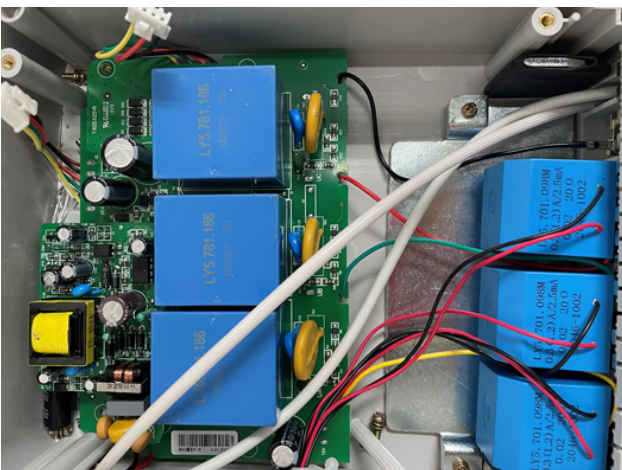

POWER BOARD

Connectivity solutions

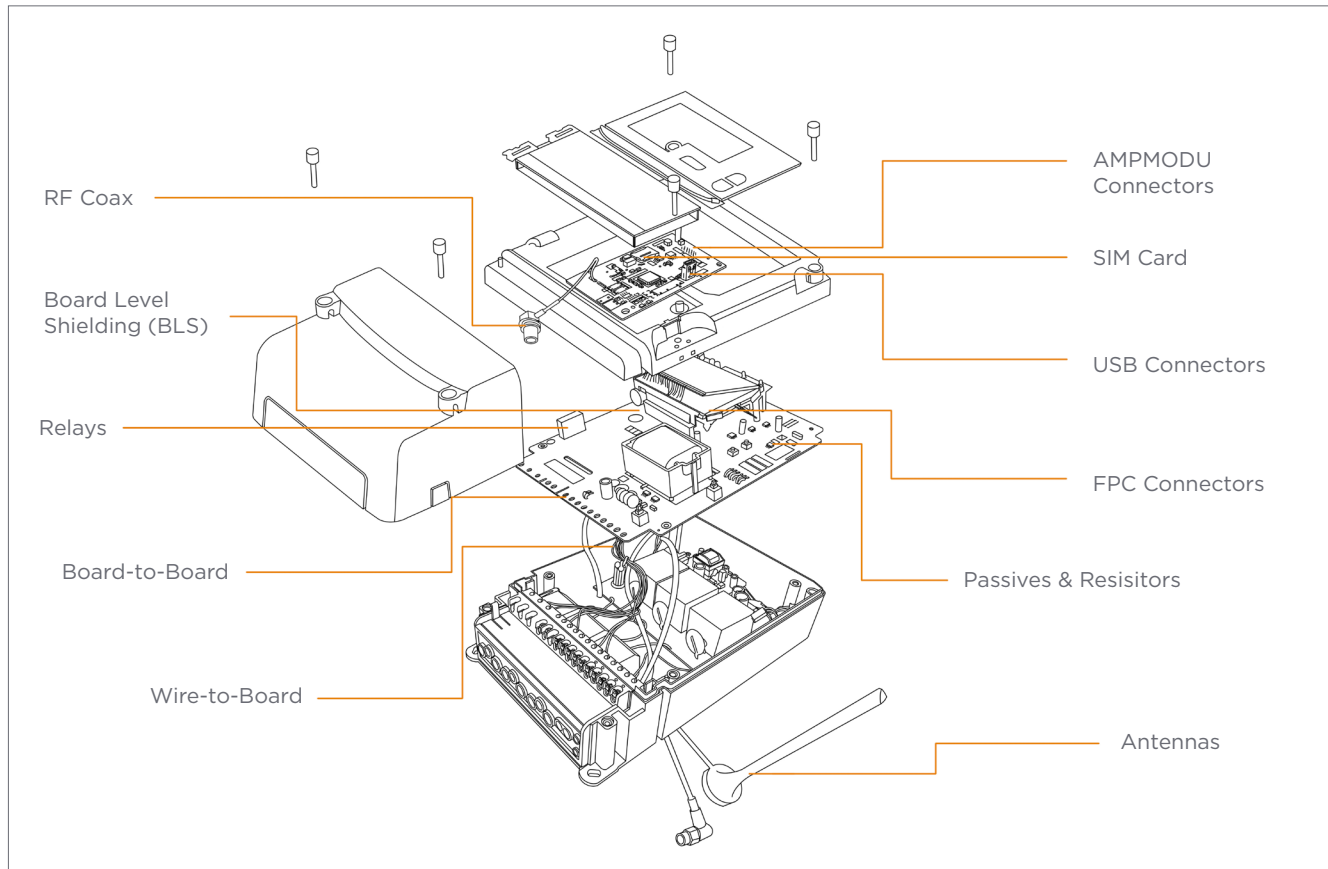

EXPLODED VIEW

TE Connectivity's (TE) reliable, compact, high performance products, including wire-to-board, board-to-board, input and output, internal interconnects, antennas, RF connectors, board level shield and relays products can enable advanced wireless communication and connectivity supporting the development of smart metering solutions that can enable the monitoring and recording of real-time data, providing insights for utilities companies as well as help deliver a better customer experience.

For more information, click [Solution Guide](#) or visit us at www.te.com/smart-metering

te.com

TE Connectivity, TE Connectivity (logo) and Every Connection Counts are trademarks. All other logos, products and/or company names referred to herein might be trademarks of their respective owners.

The information given herein, including drawings, illustrations and schematics which are intended for illustration purposes only, is believed to be reliable. However, TE Connectivity makes no warranties as to its accuracy or completeness and disclaims any liability in connection with its use. TE Connectivity's obligations shall only be as set forth in TE Connectivity's Standard Terms and Conditions of Sale for this product and in no case will TE Connectivity be liable for any incidental, indirect or consequential damages arising out of the sale, resale, use or misuse of the product. Users of TE Connectivity products should make their own evaluation to determine the suitability of each such product for the specific application.

© 2021 TE Connectivity Ltd. family of companies All Rights Reserved.

05/21 Original