

# Kontaktbuchse 2 mm

**Einsatzbereich: - 923 Stecker  
- 940 Stecker (Signalkontakt)**

**TE Teile Nr.: 60-0023-011-P00  
IC Ref. Nr.: 60.023.11**

## Elektrische Werte

Bemessungsstrom max. 30 A\*  
Durchgangswiderstand < 3 mOhm

## Werkstoff

Kontakt Messing, vergoldet

## Anschluss

Anschlussart/-bereich Crimp/ 2,5 - 4,0 mm<sup>2</sup>  
- für Isolationscrimp max.  $\varnothing 4,3$  mm  
Abisolierlänge 7 mm  
Crimpeinstellungen sind individuell zu wählen

## Mechanische Werte

Steckzyklen 500

## Werkzeuge (nicht im Lieferumfang enthalten)

digitale Crimpzange TE Teile Nr.: C0-0236-000-000  
IC Ref. Nr.: C0.236.00

(analoge Crimpzange TE Teile Nr.: C0-0201-000-000  
IC Ref. Nr.: C0.201.00)

(Positioniereinsatz für 2 mm Kontakte TE Teile Nr.: C0-0004-000-000  
IC Ref. Nr.: C0.004.00)

Crimpmaschine TE Teile Nr.: WA-1672-000-000  
IC Ref. Nr.: Wa10672

Digitaler Crimpeinsatz, mittel TE Teile Nr.: C0-0373-000-000  
IC Ref. Nr.: C0.373.00

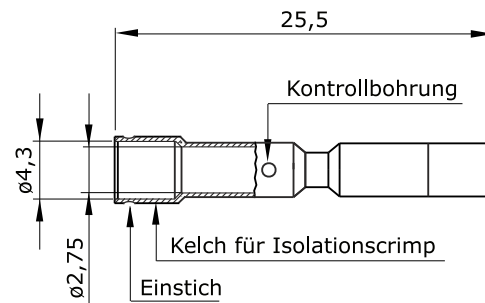

## Hauptabmessungen

Kontaktbuchse



# Contact Socket 2 mm

for: - 923 Plug  
- 940 Plug (signal contact)

TE part number: 60-0023-011-P00  
IC reference number: 60.023.11

### Electrical Data

rated current max. 30 A\*  
contact resistance < 3 mOhm

### Material

contact brass, gold plated

### Termination

cross-section crimp/ 2.5 - 4.0 mm<sup>2</sup>  
- for insulation crimp max.  $\varnothing$ 4.3 mm  
stripping length 7 mm  
crimp settings select individually

### Mechanical Data

mating cycles 500

### Tools (not part of product contents)

digital crimping tool	TE part no.: C0-0236-000-000 IC ref. no.: C0.236.00
(analog crimping tool)	TE part no.: C0-0201-000-000 IC ref. no.: C0.201.00)
(positioner for 2 mm contacts)	TE part no.: C0-0004-000-000 IC ref. no.: C0.004.00)
crimping machine	TE part no.: WA-1672-000-000 IC ref. no.: Wa10672
digital crimp insert, medium	TE part no.: C0-0373-000-000 IC ref. no.: C0.373.00

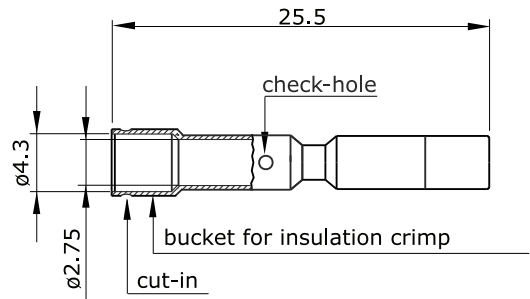

**Main Dimension**  
contact socket

