

MINISENSE 100 NM (No Mass) Vibration Sensor

SPECIFICATIONS

- High Sensitivity
- Higher Resonant Frequency
- Solderable
- Shielded
- Rugged
- Withstands High Shock

DIMENSIONS IN MM

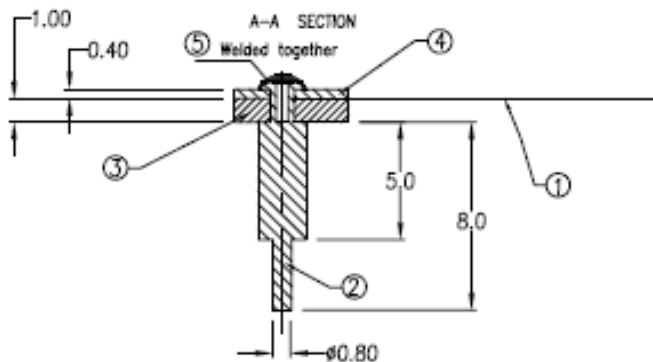
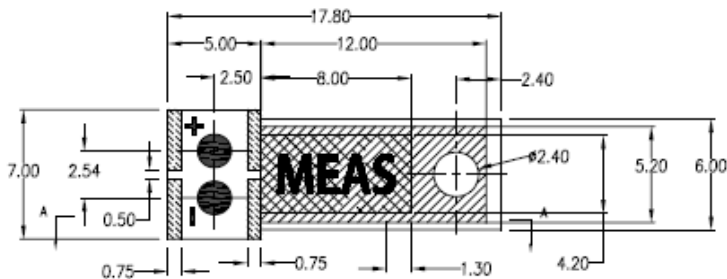

The **MiniSense 100NM** is a low-cost cantilever-type vibration sensor offering moderate sensitivity over a useful frequency band up to 200 Hz. Pins are designed for easy installation and are solderable. Horizontal and vertical mounting options are offered. The active sensor area is shielded for improved RFI/EMI rejection. Rugged, flexible PVDF sensing element withstands high shock overload. Sensor has excellent linearity and dynamic range, and may be used for detecting either continuous vibration or impacts.

FEATURES

- High Voltage Sensitivity (65 mV/g)
- Over 6 V/g at Resonance
- Horizontal or Vertical Mounting
- Shielded Construction
- Solderable Pins, PCB Mounting
- 1% Linearity
- Up to 200 Hz (12,000 rpm) Operation Below Resonance

APPLICATIONS

- Low Cost Vibration Sensing
- Car Alarms
- Body Movement
- Medical Applications
- Security Systems

PERFORMANCE SPECIFICATIONS

M100NM Voltage Sensitivity

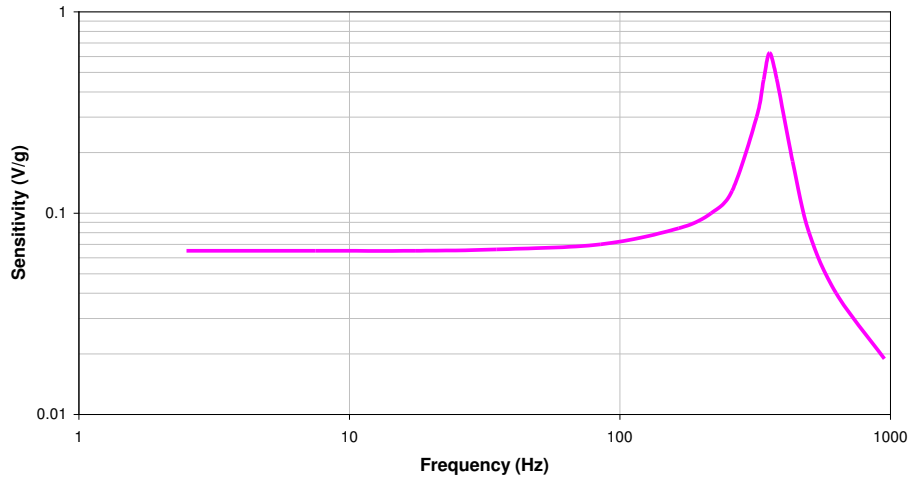

PROPERTIES/SPECIFICATIONS

Typical Properties (at 25 °C)

Parameter	Value	Units
Voltage Sensitivity (open-circuit, baseline)	65	mV/g
Charge Sensitivity (baseline)	16	pC/g
Resonance Frequency	360	Hz
Voltage Sensitivity (open-circuit, at resonance)	625	mV/g
Upper Limiting Frequency (+3 dB)	200	Hz
Linearity	+/-1	%
Capacitance	245	pF
Dissipation Factor	0.018	(none)

Environmental Specifications

Storage Temperature	-40 to +80 °C
Operating Temperature	-20 to +60 °C
Weight	Minisense 100HNM 0.2 gram

FUNCTIONAL DESCRIPTION

The **MiniSense 100NM** acts as a cantilever-beam accelerometer. When the beam is mounted horizontally, acceleration in the vertical plane creates bending in the beam, due to the inertia of the beam. Strain in the beam creates a piezoelectric response, which may be detected as a charge or voltage output across the electrodes of the sensor.

The sensor may be used to detect either continuous or impulsive vibration or impacts. For excitation frequencies below the resonant frequency of the sensor, the device produces a linear output governed by the "baseline" sensitivity quoted above. The sensitivity at resonance is significantly higher. Impacts containing high-frequency components will excite the resonance frequency. The ability of the sensor to detect low frequency motion is strongly influenced by the external electrical circuit, as described below (see "Electrical Description").

ELECTRICAL DESCRIPTION

The **MiniSense 100NM** behaves electrically as an "active" capacitor: it may be modelled as a perfect voltage source (voltage proportional to applied acceleration) in series with the quoted device capacitance. Any external input or load resistance will form a high-pass filter, with a roll-off frequency as tabulated above, or calculated from the formula $f(c) = 1/(2\pi RC)$. The impedance of the sensor is approximately 650 M ohm at 1 Hz. The active sensor element is electrically shielded, although care should be taken in the PCB design to keep unshielded traces as short as possible.

Lower Limiting Frequency (-3 dB roll-off)			
External R (Ω)	LLF (Hz)	Desired LLF (Hz)	Required R (Ω)
10 M	65	10	65 M
100 M	6.5	1	650 M
1 G	0.65	0.1	6.5 G

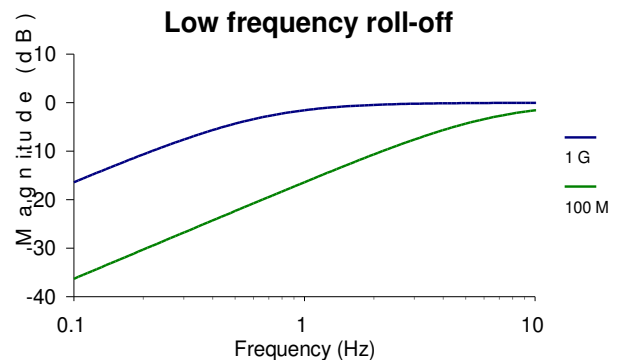
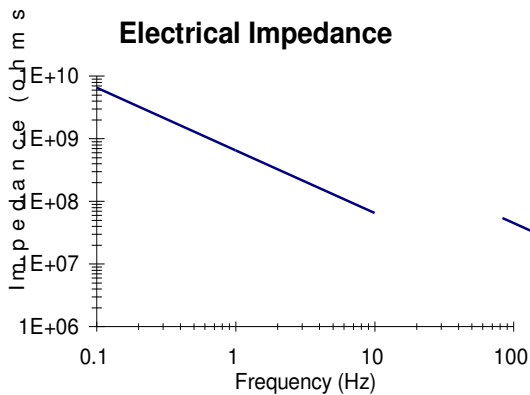

ON-AXIS SENSITIVITY

The sensitivity of the Minisense 100NM follows a cosine law, when rotated horizontally around its axis, or vertically around its mid-point. At 90 degrees rotation in either plane, both baseline sensitivity and sensitivity at resonance are at a minimum. In theory, sensitivity should be zero in this condition. It is likely that some sensitivity around the resonance frequency will still be observed – but this may be unpredictable and is likely to be at least -16 dB with reference to the on-axis response. Note that the sensitivity at 30 degrees rotation is -1.25 dB (87% of on-axis response), at 60 degrees, it falls to -6 dB (50%).

The plots below show the change in sensitivity observed for either:

- 1) Rotation about major axis of sensing element, or
- 2) Rotation about mid-point of sensing element.

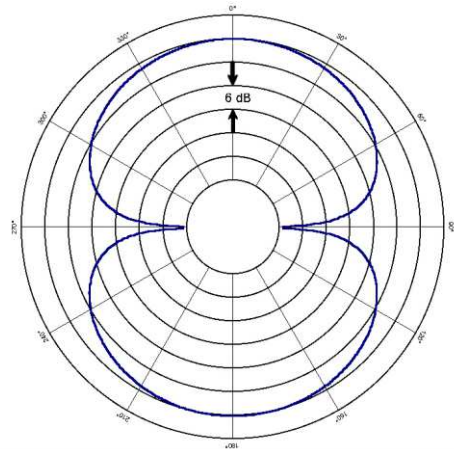
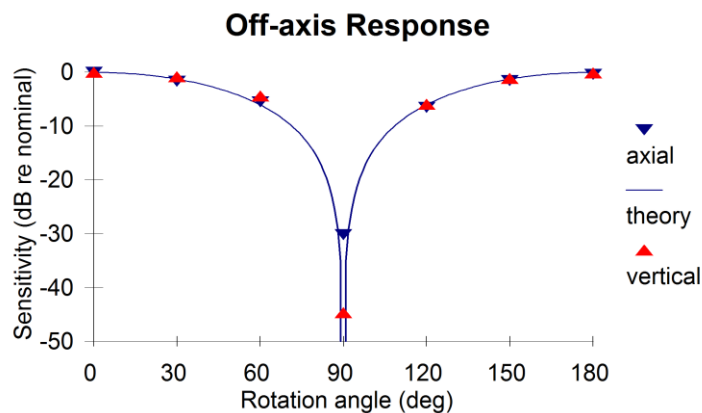

ORDERING INFORMATION

Description

Horizontal Mounting No Mass

Model No.
Minisense HNM

Part No.
1007158-1

NORTH AMERICA

Measurement Specialties, Inc.,
a TE Connectivity Company
Tel: +1-800-522-6752
Email: customercare.dtm@te.com

EUROPE

MEAS Deutschland GmbH
a TE Connectivity Company
Tel: +49-800-440-5100
Email: customercare.dtm@te.com

ASIA

Measurement Specialties (China), Ltd.,
a TE Connectivity Company
Tel: +86 0400-820-6015
Email: customercare.chdu@te.com

TE.com/sensorsolutions

Measurement Specialties, Inc., a TE Connectivity company.

Measurement Specialties, TE Connectivity, TE Connectivity (logo) and EVERY CONNECTION COUNTS are trademarks. All other logos, products and/or company names referred to herein might be trademarks of their respective owners.

The information given herein, including drawings, illustrations and schematics which are intended for illustration purposes only, is believed to be reliable. However, TE Connectivity makes no warranties as to its accuracy or completeness and disclaims any liability in connection with its use. TE Connectivity's obligations shall only be as set forth in TE Connectivity's Standard Terms and Conditions of Sale for this product and in no case will TE Connectivity be liable for any incidental, indirect or consequential damages arising out of the sale, resale, use or misuse of the product. Users of TE Connectivity products should make their own evaluation to determine the suitability of each such product for the specific application.

© 2015 TE Connectivity Ltd. family of companies All Rights Reserved.