

HIGH VOLTAGE CONTACTORS ECK250 SERIES - UP TO 500AMP

INTRODUCTION

TE Connectivity's (TE) ECK250 series high-voltage DC contactor is designed for control in latest energy applications. The ECK250 product line is a noteworthy and reliable solution for EV charging stations, solar inverters, battery energy storage systems, automated-guided vehicles (AGV) and electric forklifts. ECK250 is hermetically sealed with ceramic technology and enables high switching capability under 1000VDC. The built-in PWM module design makes it smaller to save space.

FEATURES

- Hermetically sealed with ceramic technology
- Designed with built-in economizer, hold power 1.7W
- 500A carry current capability (see cautions)
- Maximum DC breaking current at 2000A
- Maximum DC breaking voltage at 1000VDC
- Auxiliary contact version available
- Comply with DC-1 utilization category in IEC60947-4-1

APPLICATIONS

- DC charging stations
- Electric vehicles
- AGV
- Electric forklift
- Energy storage systems
- Photovoltaic inverters
- DC converters
- Battery protection boards

APPROVALS

- CE: 724-00004
- UL: E82292
- TUV: R50571784
- CCC approved

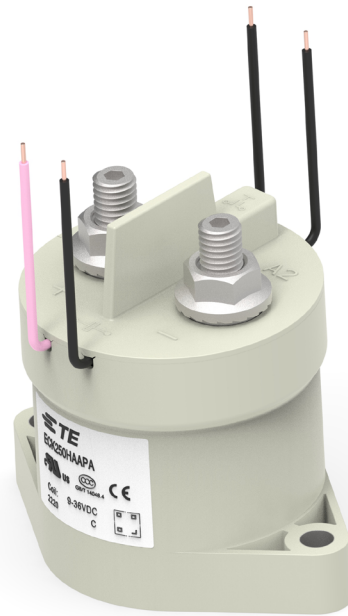

High Voltage Contactors ECK250 Series

CONTACT DATA

Contact current	500A
Maximum Switching voltage	1000VDC
Contact arrangement	1 Form X (SPST-NO-DM)
Initial contact resistance	≤ 0.4mΩ (250A, after 1 minute)
Operating time, maximum (At 23°C)	30ms
Release time, maximum (At 23°C)	10ms
Mechanical life	
With auxiliary contact	200,000 cycles
Without auxiliary contact	500,000 cycles

CONTACT RATINGS

Load	Cycles
250A, 450VDC, make/break, resistive	6000
250A, 800VDC, make/break, resistive	1000
200A, 1000VDC, make/break, resistive	1000
250A, 1000VDC, make/break, resistive	400

Note:

- Only typical rating listed, please refer to make/break curves on the next page for more details at different current and voltage.

CE DECLARATION (IEC60947-4-1)

Rated Operational Current	Utilization Category	Switching Cycles
100A	DC-1	6,050

COIL VERSIONS, DC COIL

Coil Code	Nominal Voltage	Nominal Operating Current	Max Starting Current	Operating Voltage	Maximum Operating Voltage	Release Voltage	Coil Power
A	9VDC - 36VDC	0.13A@12VDC 0.07A@24VDC	3.6A	≤9VDC	36VDC	≥3VDC	Start: 43.2W Hold: 1.7W

All figures are given for coil without pre-energization, at ambient temperature +23°C.

AUXILIARY CONTACT DATA

Contact form	1 Form A (SPST-NO)
Contact current, maximum	2A, 30VDC
Contact current, minimum	10mA, 24VDC
Contact resistance, maximum	0.4Ω @ 30VDC

INSULATION DATA

Dielectric Withstand Voltage (leakage current <1mA)	
Between open main contacts	4300Vrms
Between main contact and coil	4300Vrms
Between main contacts and auxiliary contacts	4300Vrms
Between open auxiliary contacts	750Vrms
Initial Insulation Resistance @ 1000VDC	
Between insulated elements	> 1x10 ⁹ Ω

OTHER DATA

Material compliance: EU RoHS/ELV, China RoHS, REACH, and for halogen content refer to the product compliance support Center at www.te.com/customer-support/rohssupportcenter	
Ambient temperature	-40°C to 85°C
Vibration resistance (functional)	Sine, 10-2000Hz, 6G
Shock resistance (functional)	11ms 1/2 Sine, Peak 20G
Terminal type	Screw for contact, wire for coil
Weight	380g
Packaging/Unit	Box/24 pcs.

High Voltage Contactors ECK250 Series

CURRENT CARRYING CAPABILITY CURVE

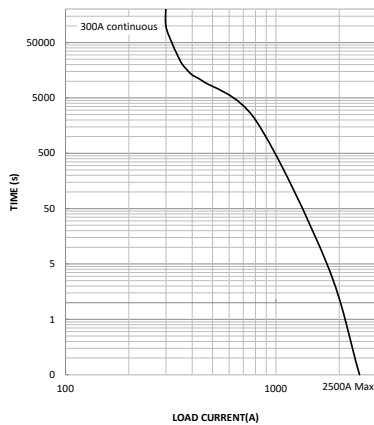

Notes:

- The data is measured at the environment temperature 85°C with cross section area of wire 185mm² minimum. Smaller cable cross section wires are also allowed depending on the end users thermal conditions..
- For 500Amp application, recommend >202mm² conductor size and please users select the appropriate connection conductor cross section or active cooling to control the temperature. Keep main contact terminals @130°C max for long-term continuous carry, @140°C max for two hours.

DIMENSIONS

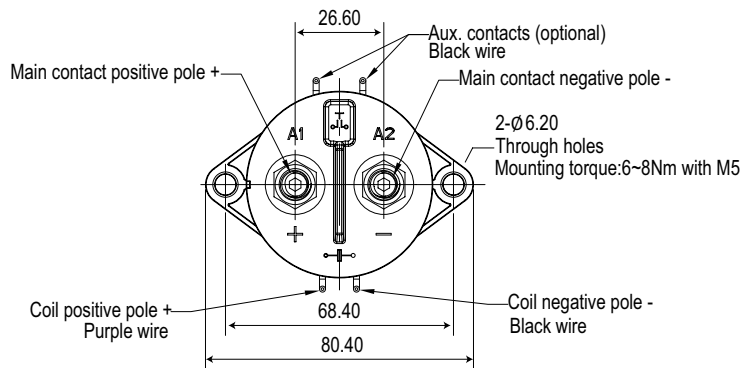

ESTIMATED MAKE & BREAK POWER SWITCHING RATINGS

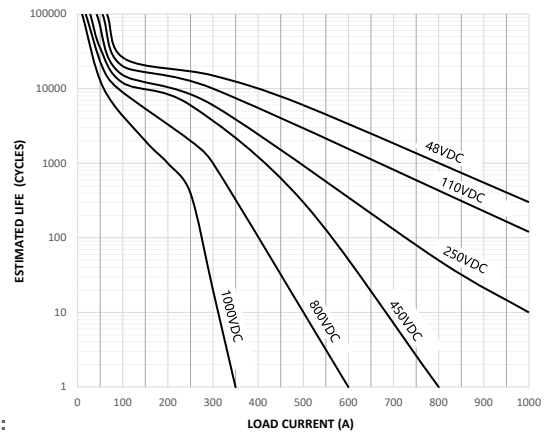

Notes:

- The curve was created based on extrapolated data with few typical points, users are recommended to confirm performance in actual application.
- The typical data were estimated with resistive load at room temperature.

CIRCUIT DIAGRAM

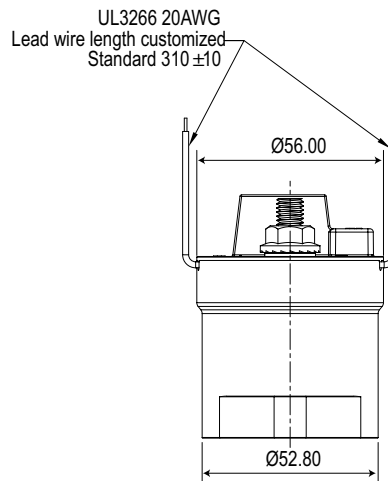
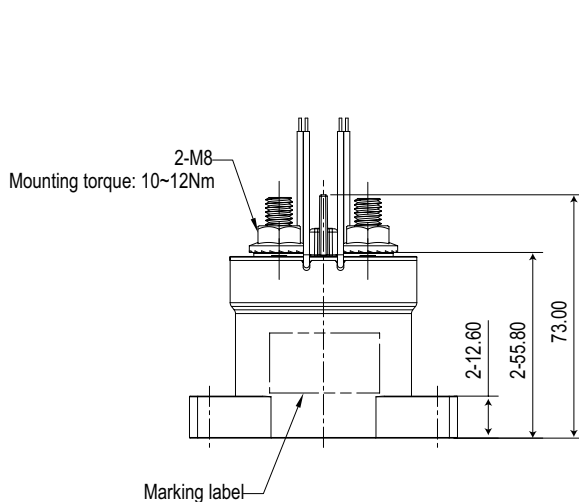
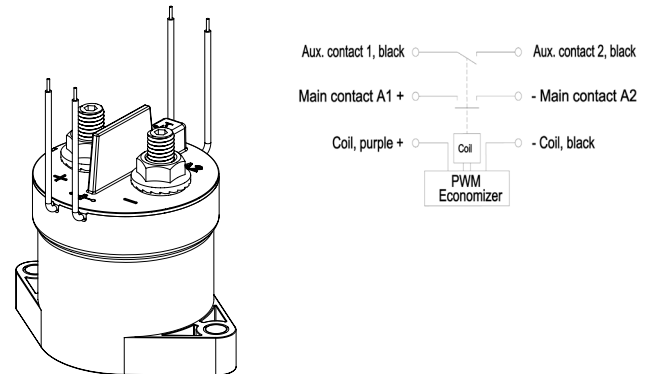

Note:

- Main contact terminal connection and coil connection with positive and negative difference.

General Tolerance	
Dimension	Tolerance
<10	±0.3
10 - 50	±0.6
>50	±1.0

ORDERING INFORMATION

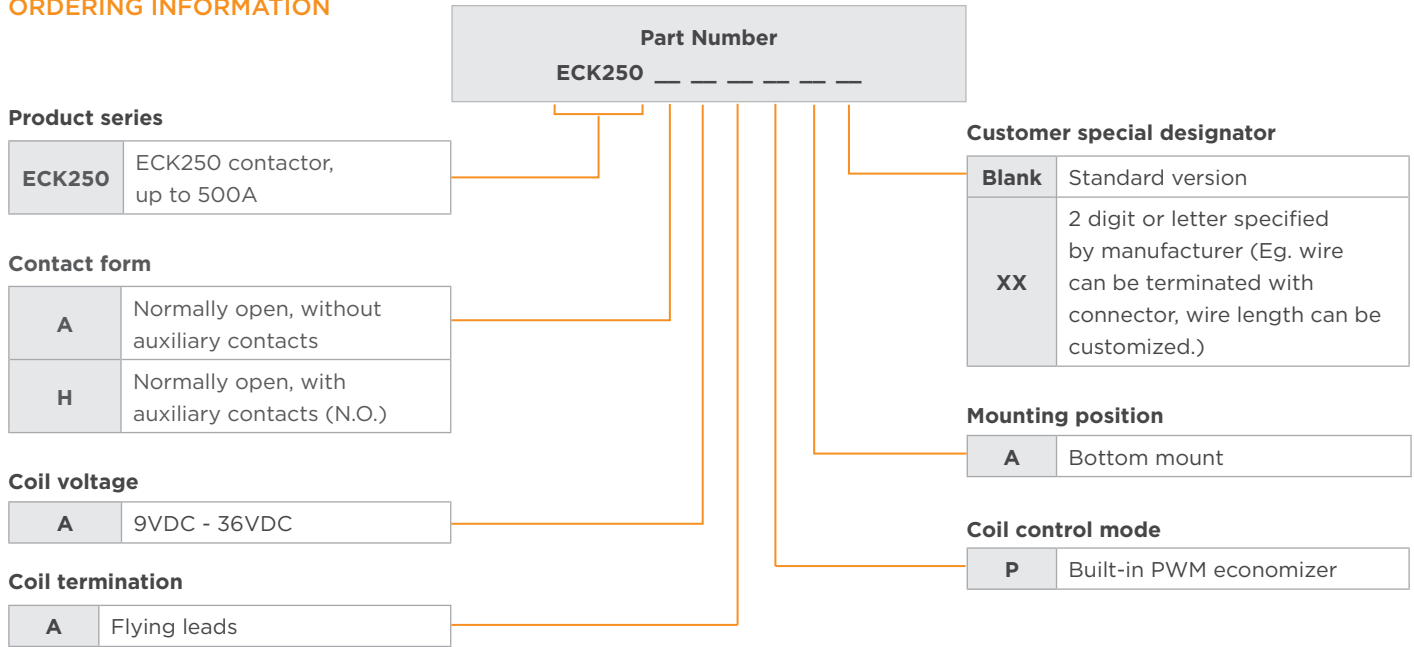

PRODUCT PART NUMBER TABLE

Product code	Contact form	Mounting position	Coil	Coil control mode	Part number
ECK250AAAPA	Normally open, without auxiliary contacts	Bottom	9VDC - 36VDC	Built-in PWM economizer	<u>2-2071567-2</u>
ECK250HAAPA	Normally open, with auxiliary contacts (N.O.)				<u>2-2071567-1</u>

Note: Only typical part numbers are listed above, other types please contact TE engineer.

CAUTIONS

- Do not use the product when product is dropped or broken.
- Avoid mounting the contactor with the main contact screw terminals in downward direction, otherwise the contactor performance will not be achieved.
- Please use correctly according to the mark on the surface of the product. Main contact terminals and coil wires have polarity difference. When the connection polarity is reversed, the electrical characteristics promised in the datasheet will not be guaranteed.
- There are diodes built in the PWM economizer of the coil inside the contactor, additional diodes are not required.
- Please consider electromagnetic interference when using the product.
- Screw locking torque of main contact terminals should be 10 N·m - 12 N·m for M8 screw. Screw locking torque of product bottom mounting should be 6 N·m - 8 N·m for M5 screw.
- Suitable for applications under Uimp 6kV.

te.com

©2024 TE Connectivity. All Rights Reserved.

TE Connectivity, TE, TE connectivity (logo) and EVERY CONNECTION COUNTS are trademarks owned or licensed by the TE Connectivity Ltd. family of companies.

All other logos, products and/or company names referred to herein might be trademarks of their respective owners.

While TE has made every reasonable effort to ensure the accuracy of the information in this document, TE does not guarantee that it is error-free, nor does TE make any other representation, warranty or guarantee that the information is accurate, correct, reliable or current. TE reserves the right to make any changes to the information contained herein without prior notice. TE Connectivity assumes only those obligations set forth in the terms and conditions for this product and shall in no event be liable for any incidental, indirect, or consequential damages arising out of the sale, resale, use, or misapplication of the product. TE expressly disclaims any implied warranties with respect to the information contained herein, including, but not limited to, implied warranties of merchantability or fitness for a particular purpose. Dimensions, specifications and/or information contained herein are for reference purposes only and are subject to change without notice. Consult TE for the latest dimensions, specifications and/or information. Users of TE Connectivity products must make their own assessment as to whether the respective product is suitable for the respective desired application.

Issue Date: 04/24 ED