



## MODEL 8711-01 INDUSTRIAL IEPE ACCELEROMETER

### Specifications

- Industrial IEPE Accelerometer
- Low Cost, Quick Delivery
- -55°C to +125°C Operating Range
- Top Exit Connector
- Low Noise, Wide Bandwidth

### Features

- $\pm 5g$ ,  $\pm 10g$ ,  $\pm 20g$  &  $\pm 80g$  Ranges
- Frequency Response  $>10kHz$
- Case Isolated, Internally Shielded
- Hermetically Sealed, Welded
- Annular Shear Mode
- Reverse Wiring Protection
- Stable Temperature Response

### Applications

- General Purpose
- Machine Condition Monitoring
- Preventive & Predictive Maintenance
- Industrial Applications
- Harsh Environments
- Gearbox Monitoring

The model 8711-01 are internally shielded rugged IEPE accelerometers designed for industrial condition monitoring. The accelerometers are available in four standard dynamic ranges from  $\pm 5g$  to  $\pm 80g$  and have a wide bandwidth up to greater than  $10kHz$ .

The model 8711-01 accelerometers feature a top exit MIL-C-5015 connector and are designed to operate in ambient temperature ranges from  $-55^{\circ}C$  to  $+125^{\circ}C$ .

For a side exit form factor with same performance specifications, TE Connectivity also offers the model 8021 industrial accelerometer.

For wind turbines and other elevated installations that could be exposed to lightning strike, the model 8811-01 should be selected with 5,000V protection rating.

## MODEL 8711-01 ACCELEROMETER

### Performance Specifications

All values are typical at +24°C, 80Hz and 4mA excitation unless otherwise stated. TE Connectivity reserves the right to update and change these specifications without notice.

#### Parameters

##### DYNAMIC

	±5	±10	±20	±80	Notes
Range (g)					
Sensitivity (mV/g)	1000	500	250	100	±10%
Frequency Response (Hz)	0.3-4000	0.3-4000	1-7000	1-7000	±5%
Frequency Response (Hz)	0.1-6000	0.1-6000	0.3-10000	0.3-10000	±3dB
Natural Frequency (Hz)	20000	20000	32000	32000	
Non-Linearity (%FSO)	±1	±1	±1	±1	
Transverse Sensitivity (%)	<5	<5	<5	<5	
Shock Limit (g)	2000	2000	5000	5000	
Residual Noise (g RMS)	0.00003	0.00005	0.00010	0.00015	
Weight (grams)	105	105	88	88	

##### ELECTRICAL

Compliance Voltage (Vdc)	18 to 30	See Note 1
Excitation Current (mA)	2 to 10	
Bias Voltage (Vdc)	10 to 13	Room Temperature
Output Impedance (Ω)	<100	
Insulation Resistance (MΩ)	>100	@100Vdc
Warm-up Time (sec)	<5	
Grounding	Case Isolated, Internally Shielded	

##### ENVIRONMENTAL

Temperature Response (%)	See typical temperature response on following page
Operating Temperature (°C)	-55 to +125
Storage Temperature (°C)	-55 to +125
Humidity	Hermetically Sealed, IP67

##### PHYSICAL

Sensing Element	Ceramic (shear mode)
Case Material	Stainless Steel
Mounting Torque	24 lb-in (2.7 N-m)

<sup>1</sup> For full dynamic range a minimum compliance voltage of 24Vdc is recommended

<b>Calibration supplied:</b>	CS-SENS-0100	NIST Traceable Amplitude Calibration at 80Hz
<b>Supplied accessories:</b>	AC-D03665	¼-28 to M6 mounting stud
<b>Optional accessories:</b>	316A-XXX	Cable Assembly, Straight (XXX designates length in inches, 10ft standard)
	318A-XXX	Cable Assembly, 90 Degrees (XXX designates length in inches, 10ft standard)
	AC-D03664	¼-28 to M5 mounting stud
	AC-A03663	¼-28 to ¼-28 mounting stud

The information in this sheet has been carefully reviewed and is believed to be accurate; however, no responsibility is assumed for inaccuracies. Furthermore, this information does not convey to the purchaser of such devices any license under the patent rights to the manufacturer. Measurement Specialties, Inc. reserves the right to make changes without further notice to any product herein. Measurement Specialties, Inc. makes no warranty, representation or guarantee regarding the suitability of its product for any particular purpose, nor does Measurement Specialties, Inc. assume any liability arising out of the application or use of any product or circuit and specifically disclaims any and all liability, including without limitation consequential or incidental damages. Typical parameters can and do vary in different applications. All operating parameters must be validated for each customer application by customer's technical experts. Measurement Specialties, Inc. does not convey any license under its patent rights nor the rights of others.

Typical Frequency Response

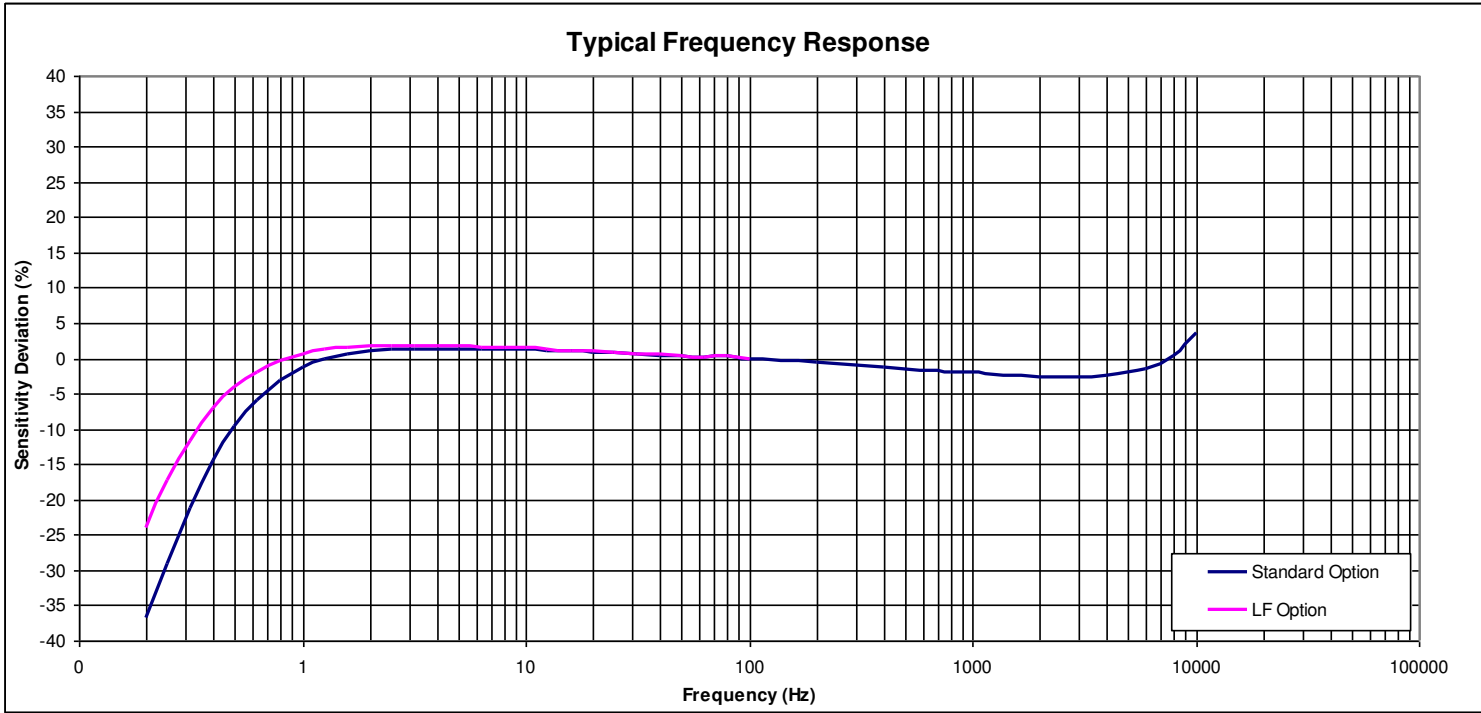

Typical Thermal Sensitivity Response

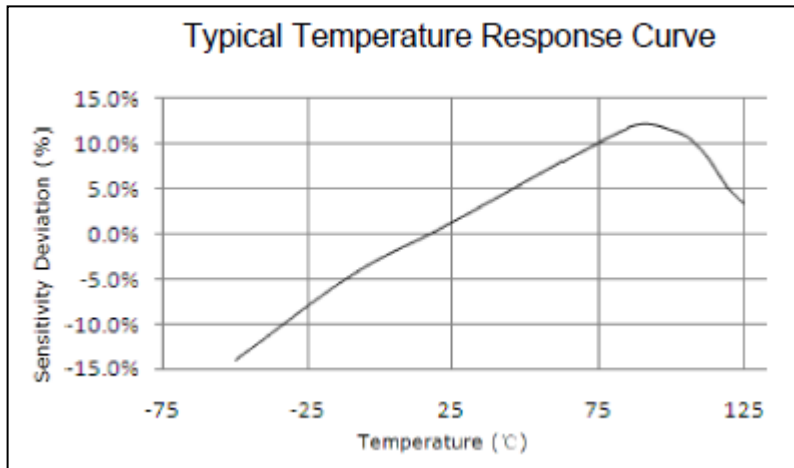

# MODEL 8711-01 ACCELEROMETER

## Dimensions

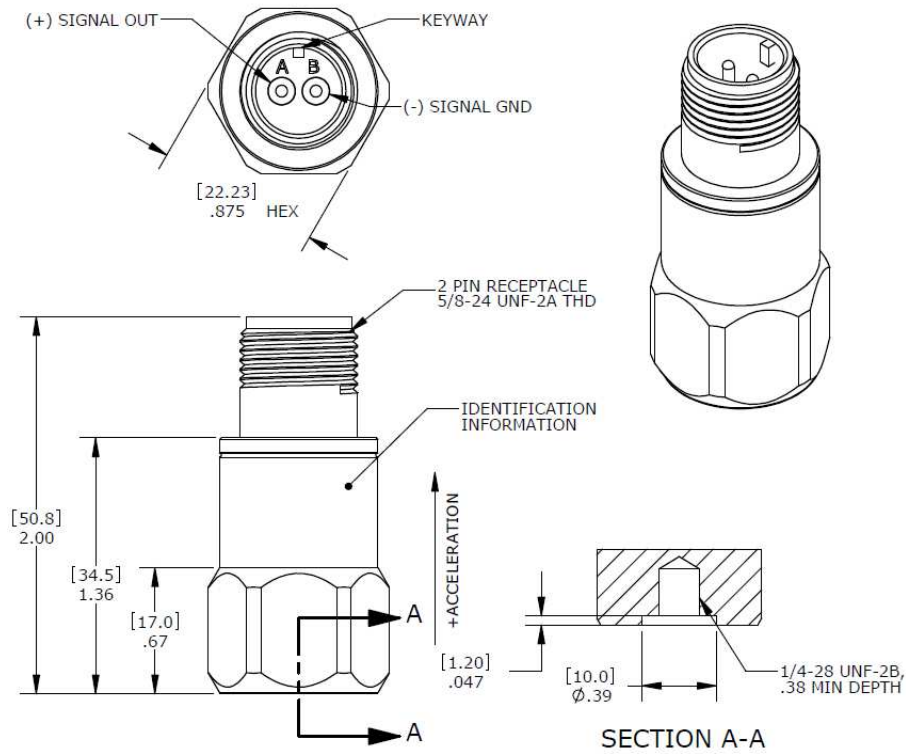

## Schematic

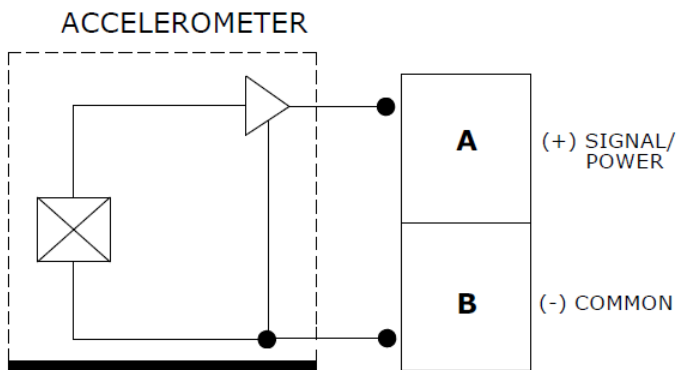

# MODEL 8711-01 ACCELEROMETER

---

## Ordering Information

8711LF-01 for 5g and 10g Range  
8711-01 for 20g and 80g Range

GGG

### Range

005 = 5g  
010 = 10g  
020 = 20g  
080 = 80g

Standard model numbers:

8711LF-01-005  
8711LF-01-010  
8711-01-020  
8711-01-080

### NORTH AMERICA

Measurement Specialties, Inc.,  
a TE Connectivity Company  
Tel: 800-522-6752  
[customercare.hmpt@te.com](mailto:customercare.hmpt@te.com)

### EUROPE

MEAS France SAS  
a TE Connectivity Company  
Tel: +31 73 624 6999  
[customercare.lcsb@te.com](mailto:customercare.lcsb@te.com)

### ASIA

Measurement Specialties (China), Ltd.,  
a TE Connectivity Company  
Tel: 0400-820-6015  
[customercare.shzn@te.com](mailto:customercare.shzn@te.com)

## te.com

TE Connectivity, TE, TE Connectivity (logo) and Every Connection Counts are trademarks. All other logos, products and/or company names referred to herein might be trademarks of their respective owners

The information given herein, including drawings, illustrations and schematics which are intended for illustration purposes only, is believed to be reliable. However, TE Connectivity makes no warranties as to its accuracy or completeness and disclaims any liability in connection with its use. TE Connectivity's obligations shall only be as set forth in TE Connectivity's Standard Terms and Conditions of Sale for this product and in no case will TE Connectivity be liable for any incidental, indirect or consequential damages arising out of the sale, resale, use or misuse of the product. Users of TE Connectivity products should make their own evaluation to determine the suitability of each such product for the specific application.

© 2019 TE Connectivity Corporation. All Rights Reserved.

Version # 08/2020

