

REVISIONS

REV.	ECO	DESCRIPTION	DATE	APPROVED
M	09-0025474	ALIGN W/GVI-GER-7218	02JUN2009	DLM

SA120B  
 CONTACTOR, 3PDT  
 60 AMP, 28 VDC COIL  
 GASKET SEALED

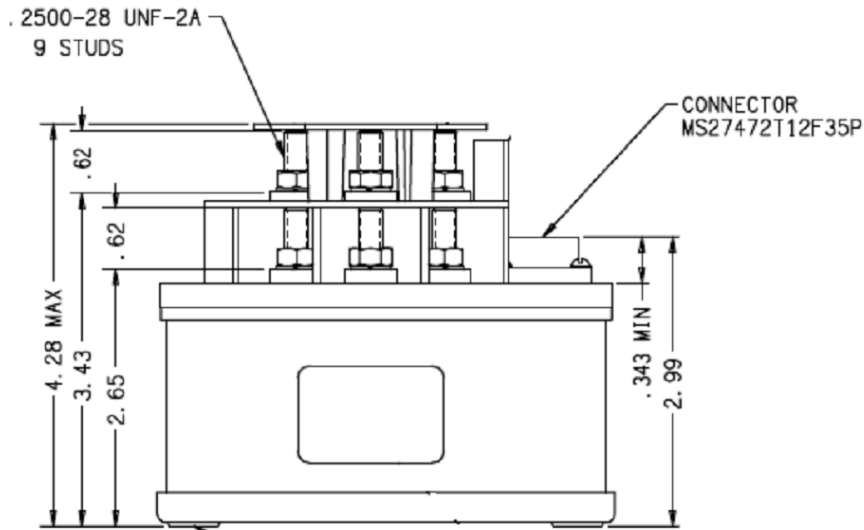
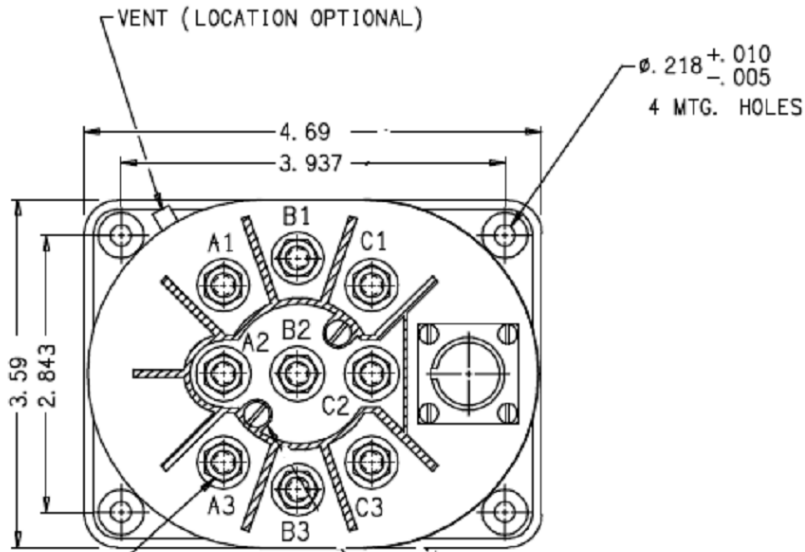

FOUR MTG. HOLES SHALL BE PAINT FREE ON BOTH SIDES OF THE MOUNTING FLANGES FOR GROUNDING PURPOSES

ALL DIMENSIONS ARE IN INCHES



TE CONNECTIVITY  
 175 N. DIAMOND STREET MANSFIELD,  
 OHIO 44902

TITLE  
 CONTACTOR, 3PDT  
 60 AMP, 28 VDC COIL  
 GASKET SEALED

TE P.N.  
 1616042-3

DWG NO.  
 SA120B

DS DATA SHEET

CAGE CODE  
 74063

SCALE  
 NONE

SHEET  
 1 OF 2

REV  
 M

## GENERAL SPECIFICATION

<b>CONSTRUCTION</b>	<b>GASKET SEALED</b>
<b>MAIN CONTACTS</b>	
CONFIGURATION	3PDT SIDE STABLE
VOLTAGE (NOMINAL)	115/200 VAC 400HZ
CURRENT RESISTIVE	60 AMPERES
INDUCTIVE	60 AMPERES
OVERLOAD (5 MIN)	75 AMPERES
OVERLOAD (10 SEC)	175 AMPERES
RUPTURE	600 AMPERES
<b>AUX CONTACTS</b>	
CONFIGURATION	6PDT
VOLTAGE (NOMINAL)	28 VDC, 115VAC 400/60 HZ
CURRENT RESISTIVE	5 AMPERES
INDUCTIVE	3 AMPERES
LAMP	1 AMPERES
LOW LEVEL	10 MILLIAMPERES @
<b>COIL DATA</b>	
DUTY CYCLE	CONTINUOUS
OPERATE VOLTAGE	28 VDC
OPERATE VOLTAGE (MAX)	32 VDC
OPERATE VOLTAGE (MIN)	18 VDC
DROPOUT VOLTAGE	2-7 VDC
HOLD VOLTAGE	7 VDC
COIL CURRENT (MAX)	.40 AMPERES AT 20°C 28 VDC
OPERATE TIMES	AT 20°C      AT -55°C      AT 71°C
	28 VDC      32 VDC      18 VDC
PICKUP TIME	50 mS (MAX)    10 mS (MIN)    100 mS (MAX)
DROPOUT TIME	25 mS (MAX)    40 mS (MAX)    10 mS (MIN)
TIMING (MAX)	2 MILLISECONDS
BOUNCE (MAX)	3 MILLISECONDS
STAGGER TIME (MAX)	5 MILLISECONDS
TRANSIENT SUPPRESSION	±42 VDC REFERENCED TO ZERO VOLTS
<b>ENVIRONMENTAL</b>	
ALTITUDE (MAX)	
LIFE ELECTRICAL (MIN)	50,000 FEET
LIFE MECHANICAL (MIN)	50,000 CYCLES
WEIGHT (MAX)	100,000 CYCLES
	2.7 LBS

### SCHEMATIC

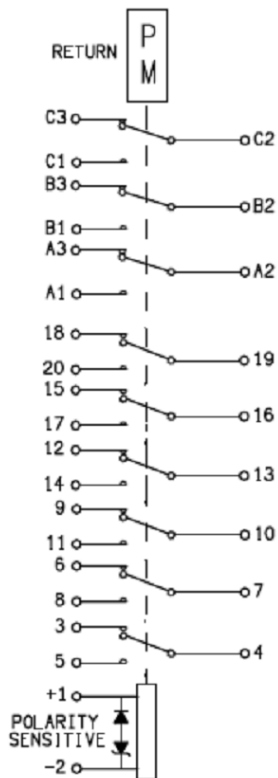

TE CONNECTIVITY  
175 N, DIAMOND STREET MANSFIELD,  
OHIO 44902

TITLE

CONTACTOR, 3PDT  
60 AMP, 28 VDC COIL  
GASKET SEALED

TE P.N.

1616042-3

DWG NO.

SA120B

THIRD ANGLE PROJECTION

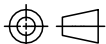

THIS DRAWING PREPARED  
IN ACCORDANCE WITH  
ANSI/ASMEY14.5M-1982

CAGE CODE

74063

SCALE

NONE

SHEET

2 OF 2

REV

M