

DH-25CM
 CONTACTOR-3PST, NO
 120AMP., 400Hz, 28 VDC COIL

REVISIONS

REV.	ECO	DESCRIPTION	DATE	APPROVED
P	34653	(REF) ADDED TO CONNECTOR	06JAN1998	RSS

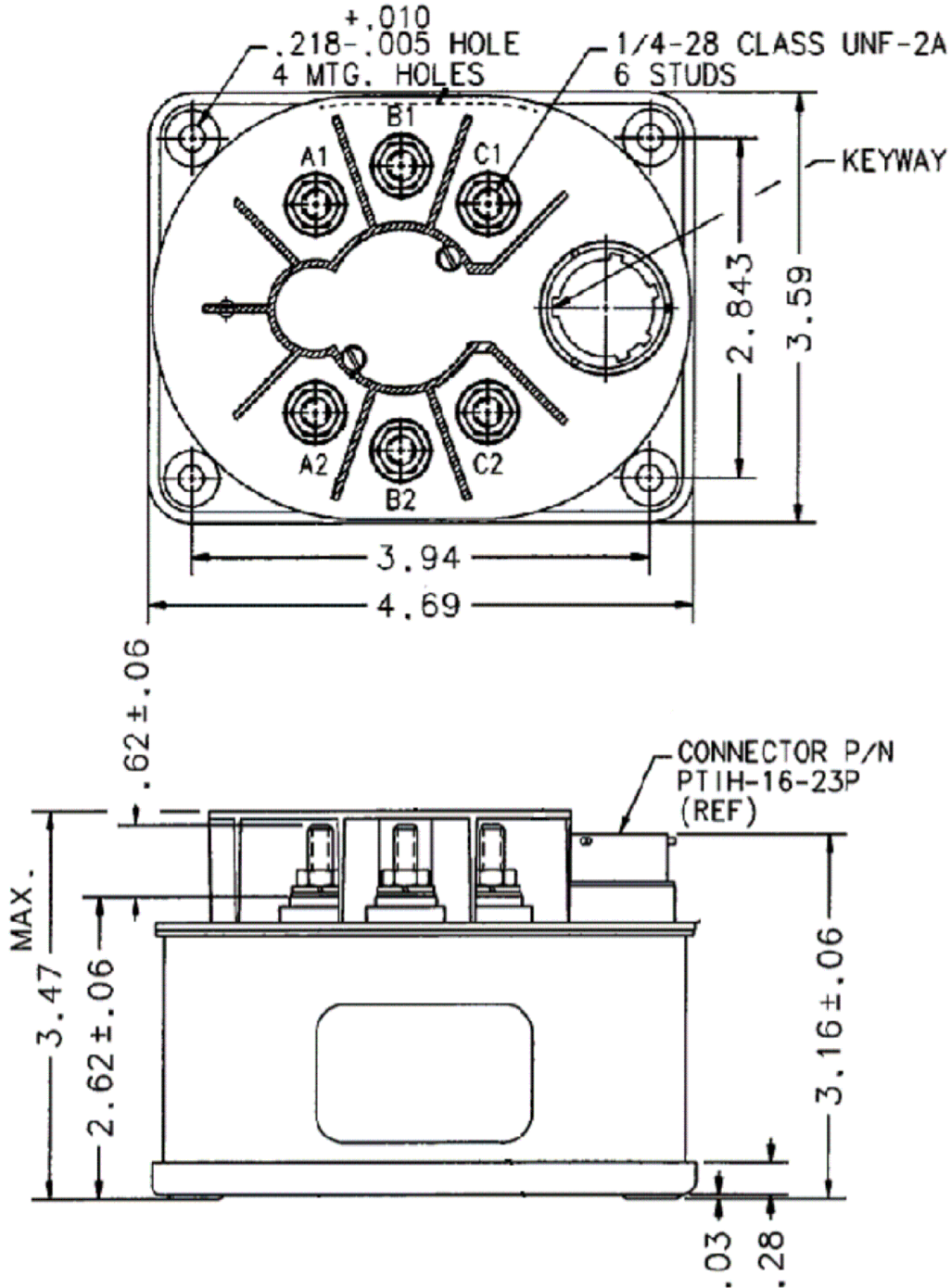

ALL DIMENSIONS ARE IN INCHES



TE CONNECTIVITY
 175 N. DIAMOND STREET MANSFIELD,
 OHIO 44902

TITLE

CONTACTOR-3PST, NO
 120AMP., 400Hz, 28 VDC COIL

TE P.N.

1616017-3

DWG NO.

DH-25CM

DS

DATA SHEET

CAGE CODE
 74063

SCALE
 NONE

SHEET
 1 OF 2

REV
 P

GENERAL SPECIFICATION

CONSTRUCTION CONTACTS NOMINAL CONTACT VOLTAGE MAIN CONTACT CONFIGURATION RATING: RESISTIVE INDUCTIVE AUXILIARY CONTACT CONFIGURATION RATING NOMINAL COIL VOLTAGE PICKUP VOLTAGE DROPOUT VOLTAGE TEMPERATURE RANGE MIN. OPERATING CYCLES MAX. WEIGHT	HERMETICALLY SEALED 115/200 VAC, 400 HZ 3PST NO 120 AMP, 400 HZ 120 AMP, 400 HZ 7PST, 3 N.O. - 4 N.C 7.5 AMP, 400 HZ 28 VDC 21 VDC MAX. AT 120°C 18 VDC MAX. AT 71°C 7 +0, -5.5 VDC -55°C TO +120°C 50,000 2 LBS. 6 OZ.
--	--

SCHEMATIC

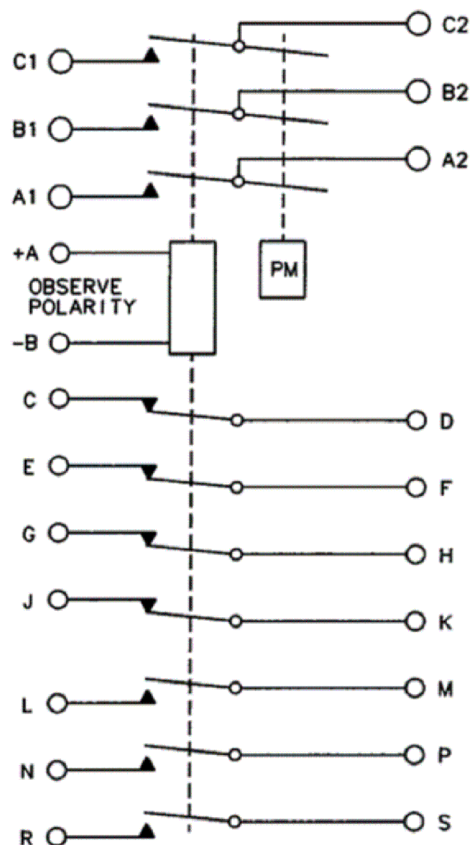

TE
 TE CONNECTIVITY
 175 N, DIAMOND STREET MANSFIELD,
 OHIO 44902

TITLE
 CONTACTOR-3PST, NO
 120AMP., 400Hz, 28 VDC COIL

TE P.N.
 1616017-3

DWG NO.
 DH-25CM

DS DATA SHEET

CAGE CODE
 74063

SCALE
 NONE

SHEET
 2 OF 2

REV
 P