

MODEL 1203 ACCELEROMETER



SPECIFICATIONS

- DC Response Triaxial Accelerometer
- Durable, Low Noise Cable
- Reliable Performance
- Low Cost, Rugged

The **Model 1203 Accelerometer** is a small, compact triaxial device designed for vehicle impact and road testing. Its mechanical overload stops provide high shock protection in rugged applications. Featuring ranges from $\pm 50g$ to $\pm 1000g$ and frequency response to 3000 Hz, this sensor is easily mounted in hard to reach places on vehicles under test.

DIMENSIONS

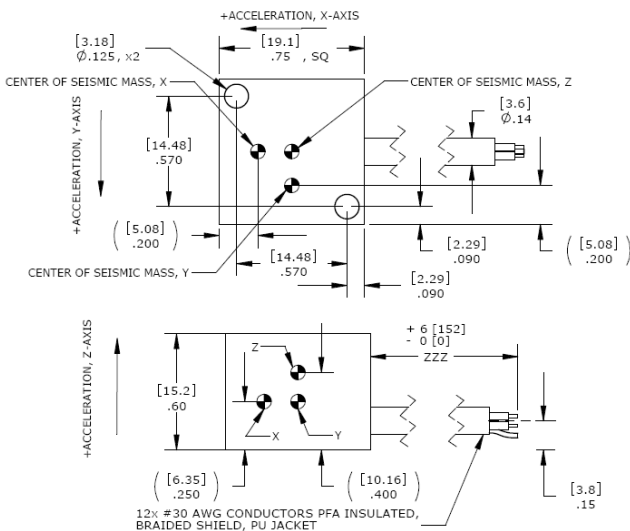

FEATURES

- Advanced MEMS Sensing Element
- $\pm 50g$ to $\pm 1000g$ Dynamic Range
- 2-10 Vdc Excitation
- 0-50 °C Temperature Range
- ± 40 mV Zero Measurand Output
- Gas Damping
- Mechanical Overload Stops
- Designed for Screw Mounting

APPLICATIONS

- Crash Testing
- Vehicle Testing
- Impact Testing
- Off-Road Testing
- Transportation Testing

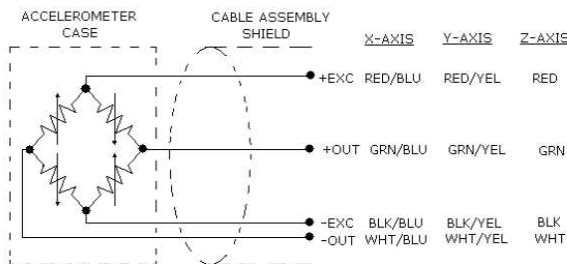

PERFORMANCE SPECIFICATIONS

All values are typical at ±24°C, 80 Hz and 10 Vdc excitation unless otherwise stated. Measurement Specialties reserves the right to update and change these specifications without notice.

Parameters	-0050	-0100	-0200	-0500	-1000	Notes
DYNAMIC						
Range(g)	±50	±100	±200	±500	±1000	
Sensitivity (mV/g) ¹	2.0	0.9	0.9	0.40	0.15	@ 10Vdc excitation ±5%
Frequency Response (Hz)	0-600	0-800	0-1000	0-1200	0-1500	
Natural Frequency (Hz)	2000	3000	4000	6000	7000	
Non-Linearity (% FS)	±1	±1	±1	±1	±1	
Damping Ratio	0.7	0.5	0.5	0.3	0.1	Typical
Transverse Sensitivity (%)	<3	<3	<3	<3	<3	
Shock Limit (g)	3000	3000	4000	5000	5000	
ELECTRICAL						
Zero Acceleration Output (mV)	<±40					
Excitation (Vdc)	2 to 10					
Input Resistance (Ω)	2400-6000					
Output Resistance (Ω)	2400-6000					
Insulation Resistance (MΩ)	>100					@50Vdc
Ground Isolation	Isolated from mounting surface.					
ENVIRONMENTAL						
Thermal Zero Shift (%FSO/°C)	±0.05					From 0 to +50°C
Thermal Sensitivity Shift (%/°C)	±0.2					From 0 to +50°C
Operating Temperature (°C)	-20 to +85					
Humidity	Epoxy Sealed, IP65					
PHYSICAL						
Case Material	Anodized Aluminum					
Cable	12x #30 AWG Conductors, PFA Insulated, Braided Shield, PU Jacket					
Weight (grams)	20					Cable Not Included
Mounting	2x #4 or M3 socket head cap screws					Torque 8 lb-in (1 N-m)

¹ Output is ratiometric to excitation voltage

Calibration supplied: CS-FREQ-0100 NIST Traceable Amplitude Calibration from 20Hz to ±5% Frequency Limit

Optional accessories: 121 Three Channel DC Differential Amplifier
140A Auto-zero Inline Amplifier

The information in this sheet has been carefully reviewed and is believed to be accurate; however, no responsibility is assumed for inaccuracies. Furthermore, this information does not convey to the purchaser of such devices any license under the patent rights to the manufacturer. Measurement Specialties, Inc. reserves the right to make changes without further notice to any product herein. Measurement Specialties, Inc. makes no warranty, representation or guarantee regarding the suitability of its product for any particular purpose, nor does Measurement Specialties, Inc. assume any liability arising out of the application or use of any product or circuit and specifically disclaims any and all liability, including without limitation consequential or incidental damages. Typical parameters can and do vary in different applications. All operating parameters must be validated for each customer application by customer's technical experts. Measurement Specialties, Inc. does not convey any license under its patent rights nor the rights of others.

ORDERING INFORMATION

PART NUMBERING Model Number+Range+Cable Length+Options

1203-GGGG-ZZZ-XXX

 | | | Options (otherwise leave blank)
 | | | Cable (360 is 360 inches)
 | | | Range (0100 is 100 g)

Installed

Optional Dash Numbers

-001 5Vdc Calibration
-002 2Vdc Calibration
-007 Lemo FGG.1B.307 and Dallas DS2401

Example: 1203-1000-072

Standard Configuration: 1000g, 72" (30ft) cable, No Options

NORTH AMERICA

Measurement Specialties, Inc.,
a TE Connectivity Company
1000 Lucas Way
Hampton, VA 23666
Sales and Customer Service
Tel: +1-800-745-8008 or
+1-757-766-1500
Fax: +1-757-766-4297
t&m@meas-spec.com

EUROPE

MEAS France SAS
a TE Connectivity Company
26 Rue des Dames
F78340 Les Clayes-sous-Bois
France
Sales and Customer Service
Tel: +33 (0) 1 79 33 00
Fax: +33(0)1 34 81 03 59
t&m@meas-spec.com

ASIA

Measurement Specialties (China), Ltd.,
a TE Connectivity Company
No. 26 Langshan Road
Shenzhen High-Tech Park (North)
Nanshan District, Shenzhen 518057
China
Sales and Customer Service
Tel: +86 755 3330 5088
Fax: +86 755 3330 5099
t&m@meas-spec.com

TE.com/sensorsolutions

Measurement Specialties, Inc., a TE Connectivity company.

Measurement Specialties, TE Connectivity, TE Connectivity (logo) and EVERY CONNECTION COUNTS are trademarks. All other logos, products and/or company names referred to herein might be trademarks of their respective owners.

The information given herein, including drawings, illustrations and schematics which are intended for illustration purposes only, is believed to be reliable. However, TE Connectivity makes no warranties as to its accuracy or completeness and disclaims any liability in connection with its use. TE Connectivity's obligations shall only be as set forth in TE Connectivity's Standard Terms and Conditions of Sale for this product and in no case will TE Connectivity be liable for any incidental, indirect or consequential damages arising out of the sale, resale, use or misuse of the product. Users of TE Connectivity products should make their own evaluation to determine the suitability of each such product for the specific application.

© 2015 TE Connectivity Ltd. family of companies All Rights Reserved.