

P	LTR	DESCRIPTION	DATE	DWN	APVD
	B	ECR-20-003872	13MAR2020	GK	MN

### LABEL AND LINER DESIGN

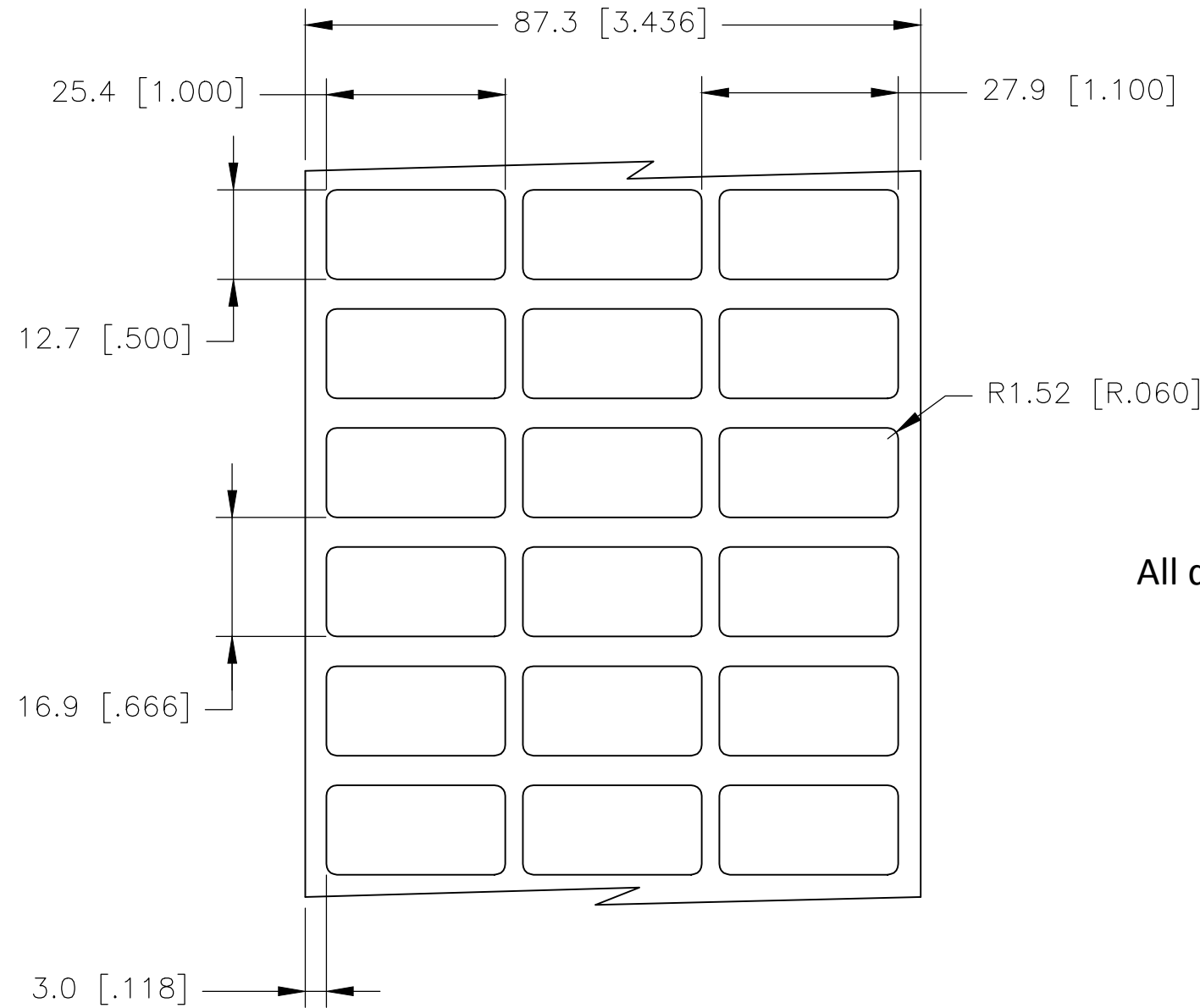

### PRESENTATION

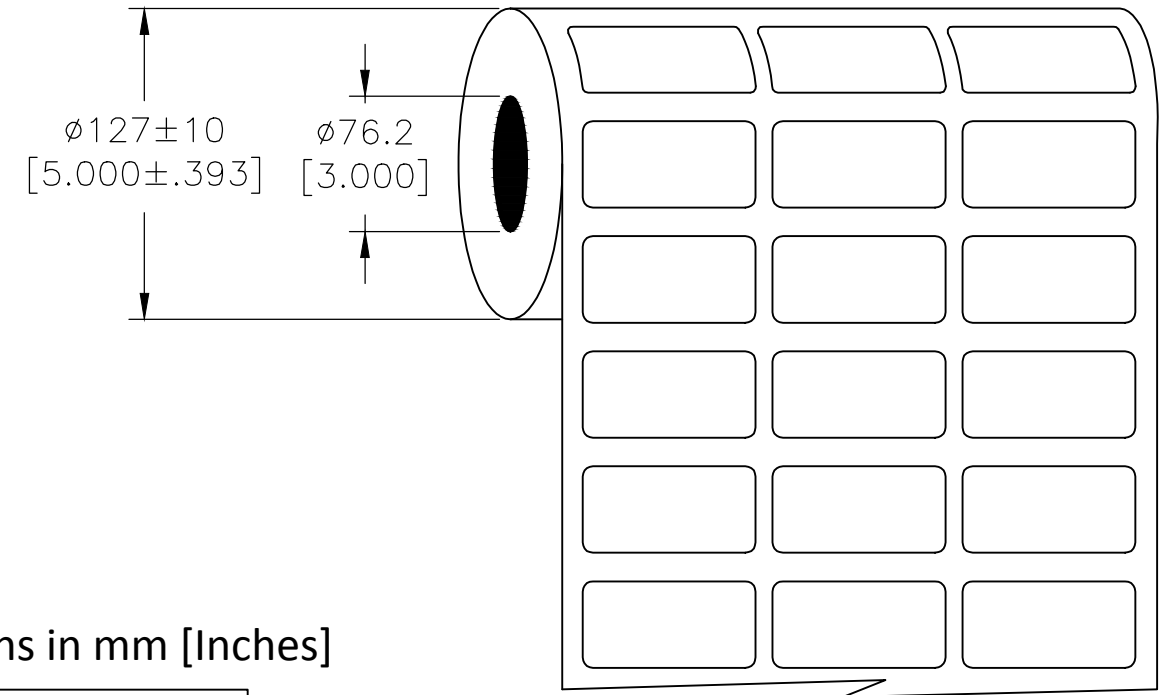

All dimensions in mm [Inches]

**TE PN: D01460-000**

**OUTSIDE WOUND  
LABEL ACROSS: 3  
PER ROLL QTY: 10000**

MATERIAL	WHITE POLYESTER
ADHESIVE TYPE	PERMANENT
LINER	GLASSINE PAPER

TOLERANCES mm [INCH]	
LABEL HEIGHT:	±0.3 [.012]
LABEL WIDTH:	±0.3 [.012]
WEB WIDTH:	±0.8 [.031]
VERTICAL REPEAT:	±0.8 [.031]*
HORIZONTAL REPEAT:	±0.8 [.031]*
PRINT POSITIONING:	±0.8 [.031]*
LEFT MARGIN:	±0.4 [.016]
QUANTITY:	-0 % +2 %
*NON ACCUMULATING	

THIS DRAWING IS A CONTROLLED DOCUMENT.	
DIMENSIONS: mm [INCHES]	TOLERANCES UNLESS OTHERWISE SPECIFIED:
	0 PLC ± -
	1 PLC ± -
	2 PLC ± -
	3 PLC ± -
	4 PLC ± -
ANGLES ± -	± -
MATERIAL SEE TABLE	FINISH -

DWN	10NOV2005
GOPALAKRISHNA HV	
CHK	10NOV2005
K. MUNZ	
APVD	10NOV2005
K. MUNZ	
PRODUCT SPEC	
TTDS-073	
APPLICATION SPEC	
WEIGHT	0.029g

TE Connectivity		NAME		RESTRICTED TO
		WP - WHITE POLYESTER LABELS		
SIZE	CAGE CODE	DRAWING NO	-	
A3	C2290	G-WP-254127-10-9	-	
CUSTOMER DRAWING		SCALE	SHEET	REV
		NTS	1 OF 1	B