

P	LTR	DESCRIPTION	DATE	DWN	APVD
A		ORIGINAL ISSUE	10AUG2023	JM	-
AI		ECR-23-186865	12SEP2023	JM	-

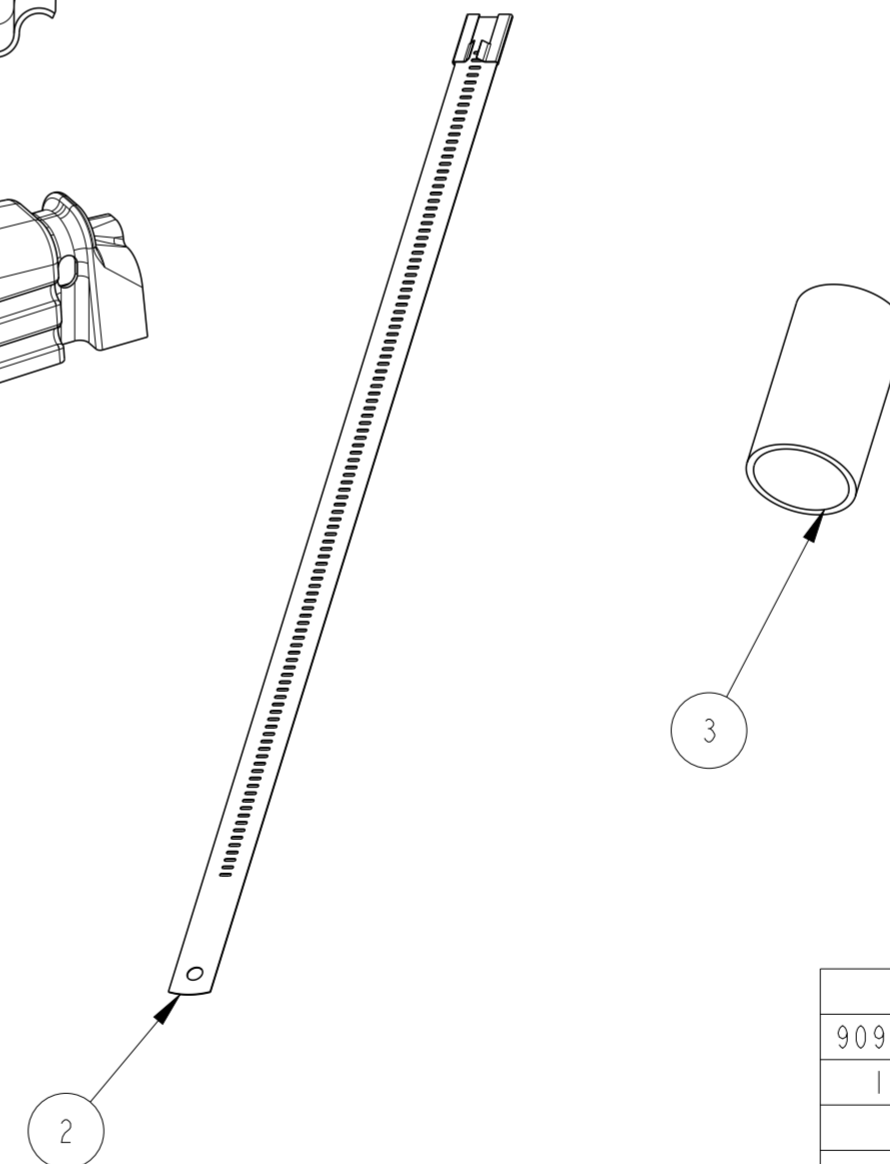
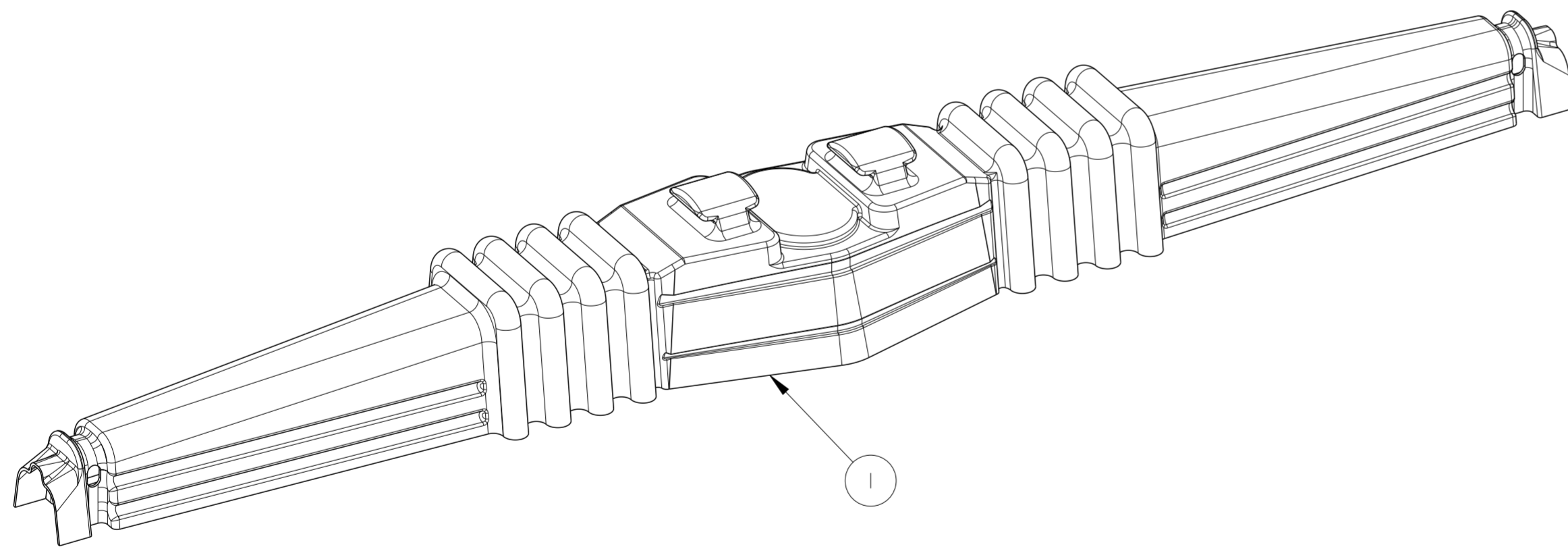
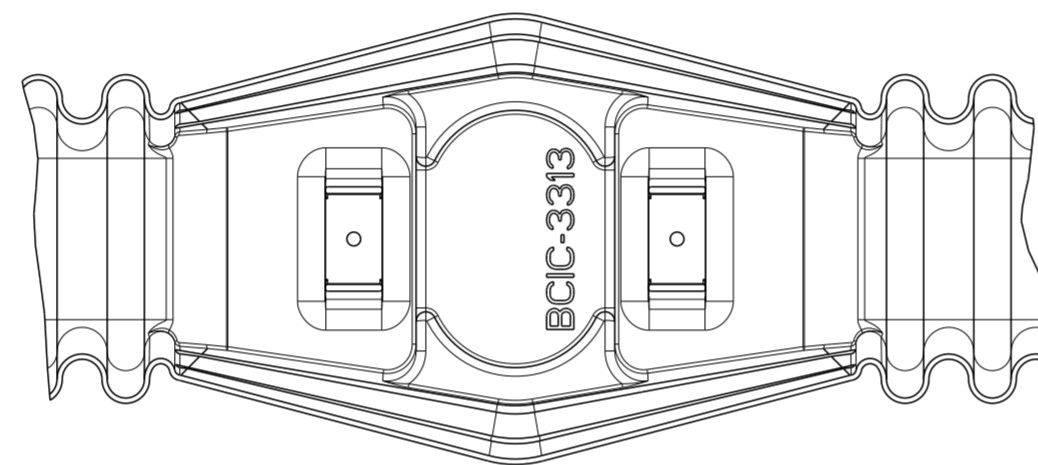
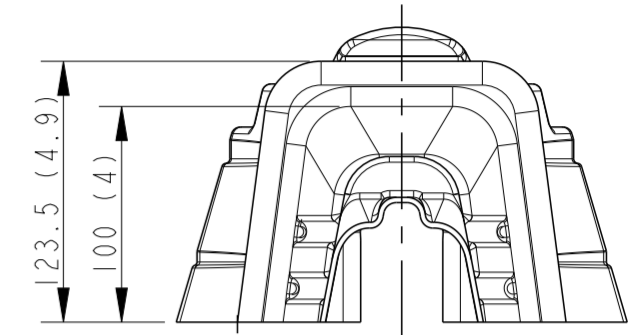
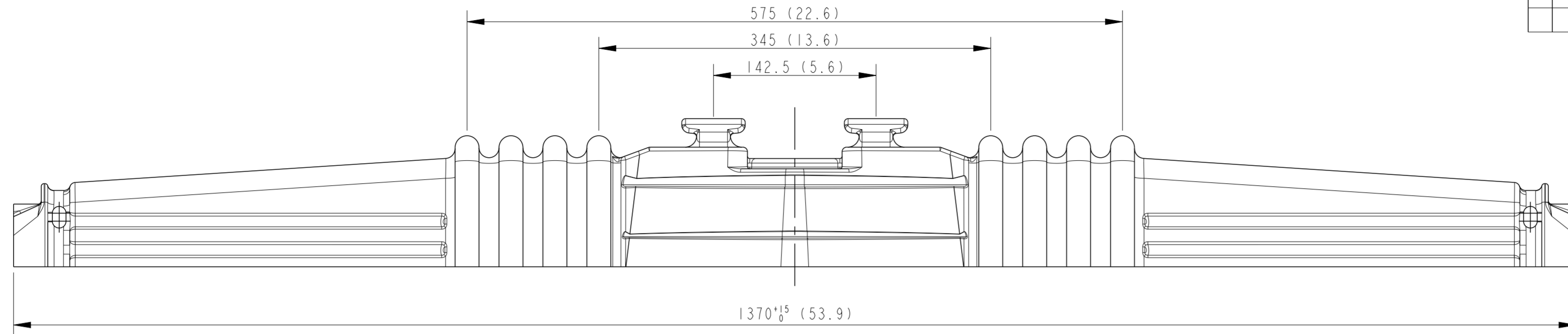

NOTES: (UNLESS OTHERWISE SPECIFIED)

MATERIAL: RED BCIS
 WALL THICKNESS: 2.5mm (0.1") NOMINAL, 1.5mm (0.06") MINIMUM
 TOLERANCE: 3mm (0.125") UNLESS OTHERWISE NOTED.
 FILLETS/RADII: R6mm (0.25") UNLESS NOTED.
 5mm FLANGE PERMISSIBLE ALL-AROUND PART.
 NO WRINKLES OR PINCHES PERMITTED. COLD MARKS ARE ALLOWABLE AS LONG AS THE WALL THICKNESS IN THESE REGIONS MEETS REQUIREMENTS.
 EACH BOX LABELLED WITH DESCRIPTION, LOT NUMBER, PART NUMBER, MANUFACTURING DATE, QUANTITY & WEIGHT.

TCPN	DESCRIPTION	TCPN	DESCRIPTION		
909845-000	BCIC-3313-(B3)	164539-000	BCIC-3313-(B24)		
ITEM #	DESCRIPTION	QTY	ITEM #	DESCRIPTION	QTY
1	BCIC-3313	3	1	BCIC-3313	24
2	BCIC-331x-LATCH	12	2	BCIC-331x-LATCH	96
3	BCIC-331x-SPACER	6	3	BCIC-331x-SPACER	48
4	EPP-0595-DE	1	4	EPP-0595-DE	1

THIS DRAWING IS A CONTROLLED DOCUMENT.		DWN J. MULLIGAN 05JUL2023	TE Connectivity	
DIMENSIONS: mm (inches)		CHK M. JAMES 05JUL2023		
TOLERANCES UNLESS OTHERWISE SPECIFIED:		APVD I. BOND 05JUL2023	NAME BCIC-3313-(Bxx) SEE TABLE	
0 PLC ± 1 PLC ± 2 PLC ± 3 PLC ± 4 PLC ± ANGLES ± FINISH -		PRODUCT SPEC -	RESTRICTED TO -	
MATERIAL SEE TABLE		APPLICATION SPEC -	SIZE A2	CAGE CODE 00779
		WEIGHT -	DRAWING NO G-WAP-BCIC-0106-C	
		CUSTOMER DRAWING	SCALE 3:1	SHEET 1 OF 1
			REV A1	