

THIS DRAWING IS UNPUBLISHED.

RELEASED FOR PUBLICATION

20

© COPYRIGHT 20 BY -

ALL RIGHTS RESERVED.

REVISIONS

P	LTR	DESCRIPTION	DATE	DWN	APVD
	B	INITIAL	18SEP2017	YC	CW

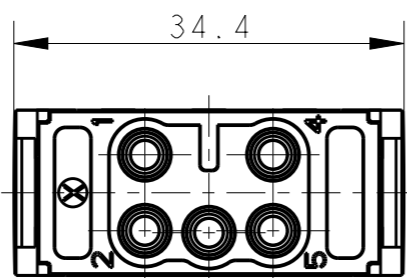
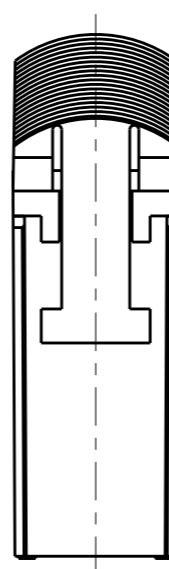
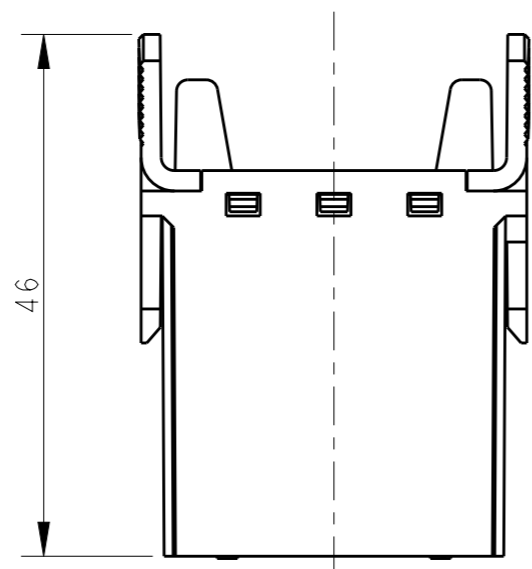
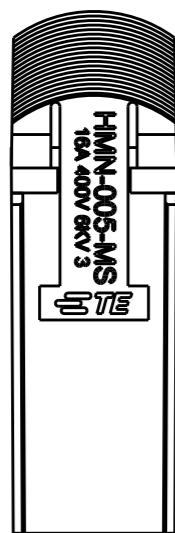
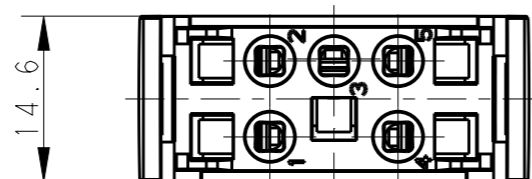
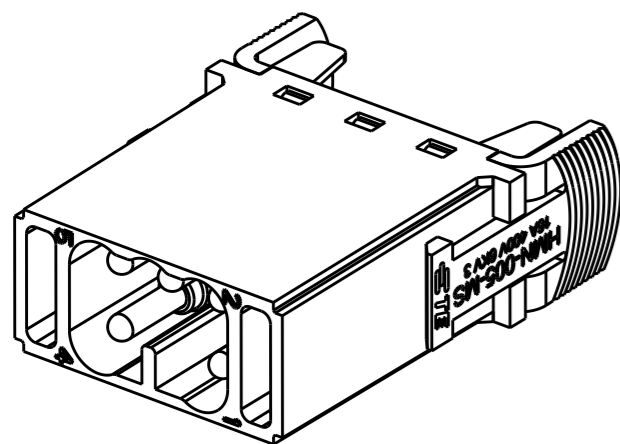

NOTES:

- TECHNICAL CHARACTERISTICS:
 INSULATION MATERIAL: PC
 RATED VOLTAGE: 400V
 RATED CURRENT: 16A
 INSULATION RESISTANCE: $\geq 400M\Omega$
 RATED IMPULSE VOLTAGE: 6KV
 POLLUTION DEGREE: 3
 CONTACT RESISTANCE: $\leq 5m\Omega$
 FLAMMABILITY: UL94V-0
 MATING CYCLES: 500 CYCLES
 WIRE RANGE: 0.5~2.5mm²
 CONTACT TYPE: SPRING TYPE.

注释:

- 技术参数:
 绝缘材料: PC
 额定电压: 400V
 额定电流: 16A
 绝缘电阻: $\geq 400M\Omega$
 脉冲电压: 6KV
 污染等级: 3
 接触电阻: $\leq 5m\Omega$
 阻燃等级: UL94V-0
 插拔次数: 500次
 接线范围: 0.5~2.5mm²
 接线类型: 弹片连接

T2110052101-007	HMN-005-MS	HMN-005 MALE INSERT HMN-005 公插
PART NUMBER 料号	PART DESCRIPTION 描述	

THIS DRAWING IS A CONTROLLED DOCUMENT.

DIMENSIONS:	TOLERANCES UNLESS OTHERWISE SPECIFIED:
mm	
	0 PLC ±-
	1 PLC ±-
	2 PLC ±-
	3 PLC ±-
	4 PLC ±-
	ANGLES ±-
MATERIAL	FINISH
-	-
-	-

DWN	18SEP2017
YORK CHEN	
CHK	18SEP2017
GINO YAO	
APVD	18SEP2017
CHRIS WANG	
PRODUCT SPEC	108-137119
APPLICATION SPEC	114-137119
WEIGHT	-
CUSTOMER DRAWING	

				TE Connectivity	
NAME HMN-005-MS					
SIZE	CAGE CODE	DRAWING NO	RESTRICTED TO		
A3	00779	©-T2110052101007	-		
SCALE		SHEET	OF	REV	
3:2		1	1	B	