

4

3

2

1

THIS DRAWING IS UNPUBLISHED. RELEASED FOR PUBLICATION 20
© COPYRIGHT 20 BY - ALL RIGHTS RESERVED.

REVISIONS					
P	LTR	DESCRIPTION	DATE	DWN	APVD
	A	INITIAL	19JUN2018	KW	CW
	B	ECR-20-007782	24NOV2020	BS	CW

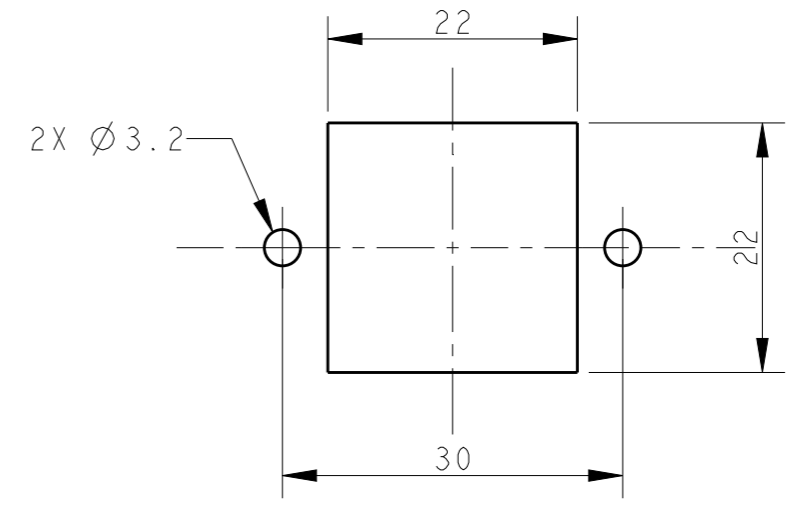
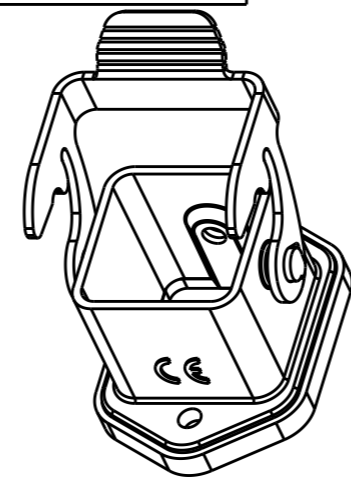
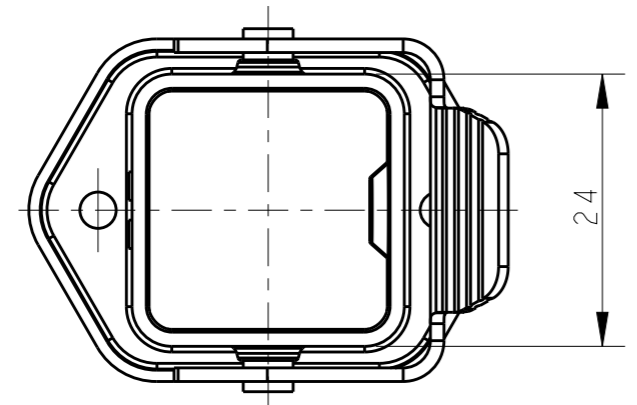

PANNEL CUT OUT

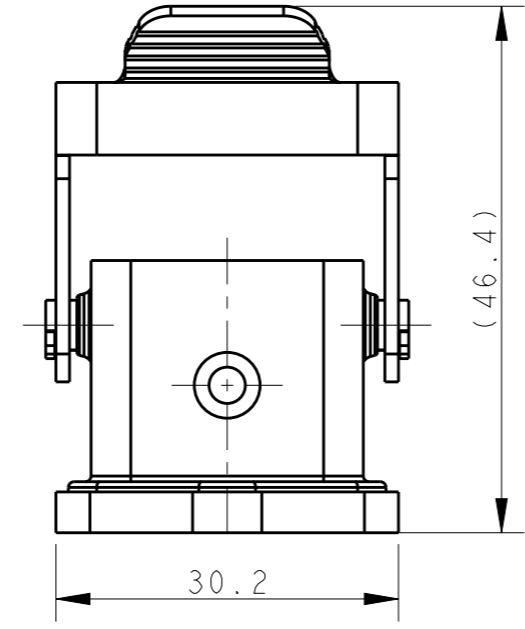
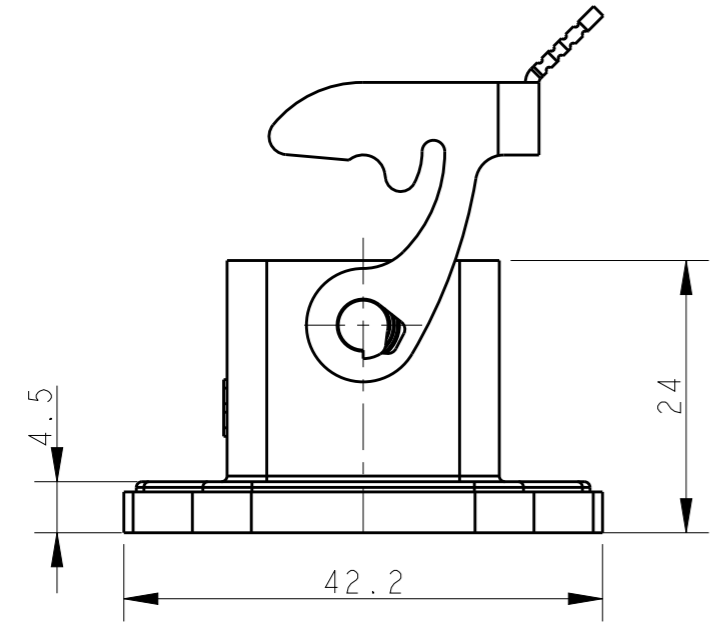

NOTES:
 1. TECHNICAL CHARACTERISTICS:
 BODY MATERIAL: DIE CAST ZINC ALLOY
 SURFACE TREATMENT: NI PLATED
 DEGREE OF PROTECTION: IP65 (MATED)

注释:
 1. 技术参数:
 主体材料: 锌合金
 表面处理: 镀镍
 防护等级: IP65(配合)

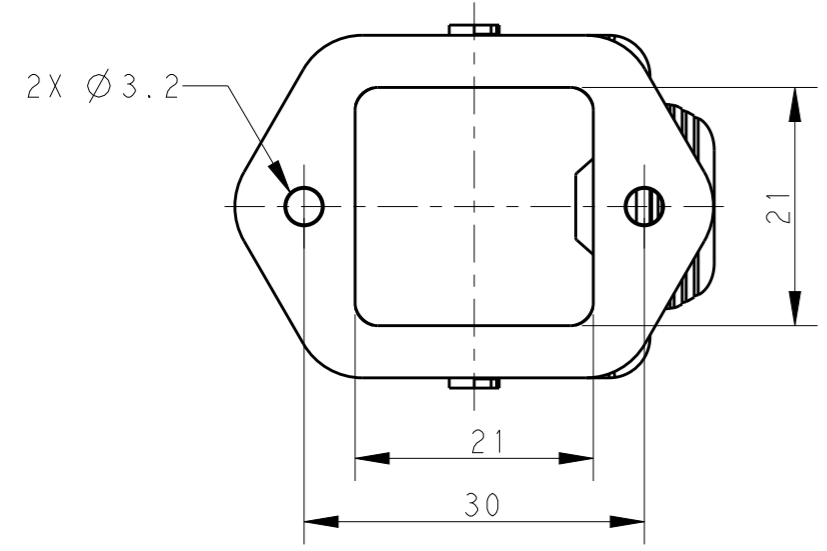

T1506032000-000	H3A-MAG-S-EMC	H3A HOUSING, EMC, BULKHEAD MOUNTED, STAINLESS STEEL SINGLE LOCKING, NICKEL PLATING H3AP屏蔽下壳, 开孔安装, 不锈钢单扣, 镀镍
PART NUMBER 料号	DESCRIPTION 描述	

THIS DRAWING IS A CONTROLLED DOCUMENT.		DWN 19JUN2018 KAYLA WANG	 TE Connectivity NAME H3A-MAG-S-EMC
DIMENSIONS: mm		CHK 19JUN2018 GINO YAO	
TOLERANCES UNLESS OTHERWISE SPECIFIED:		APVD 19JUN2018 CHRIS WANG	
0 PLC ±- 1 PLC ±- 2 PLC ±- 3 PLC ±- 4 PLC ±- ANGLES ±-		PRODUCT SPEC 108-137012	
MATERIAL	FINISH	APPLICATION SPEC 114-137012	SIZE A3
-	-	WEIGHT -	CAGE CODE 00779
CUSTOMER DRAWING		SCALE 3:2	DRAWING NO C-T1506032000000
		SHEET 1 OF 1	RESTRICTED TO -
		REV B	