

THIS DRAWING IS UNPUBLISHED. RELEASED FOR PUBLICATION
 © COPYRIGHT - BY - TE CONNECTIVITY ALL RIGHTS RESERVED.

REVISIONS				
P	LTR	DESCRIPTION	DATE	APVD
A		RELEASE PER RTS# 867887	10/17/2013	SW SR

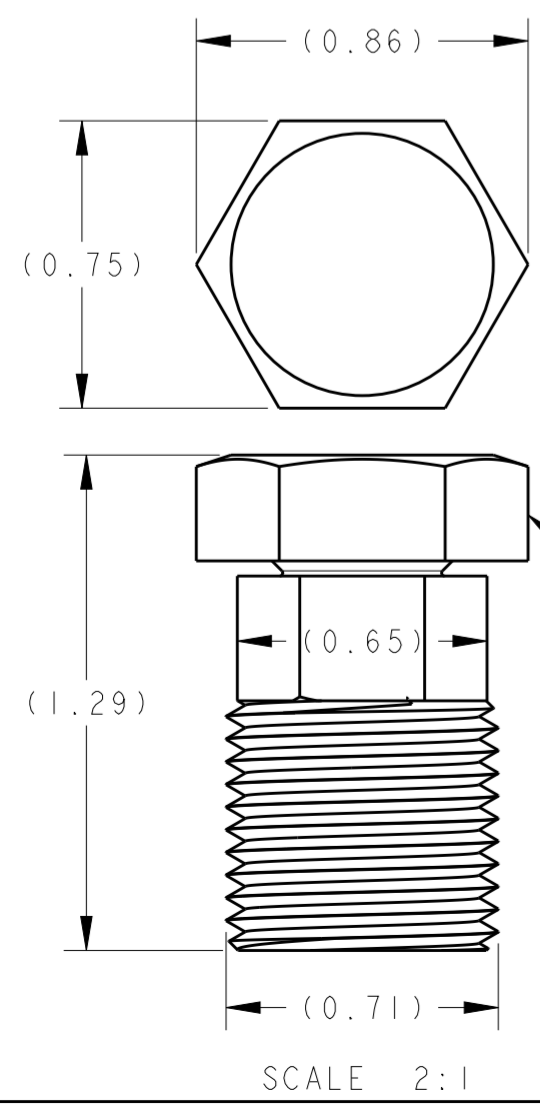

(Ref. RPN CM8495-000)
SHEAR BOLT - SHEAR TORQUE
 43 N-m +4/-0 or
 31.7 ft-lb +2.9/-0

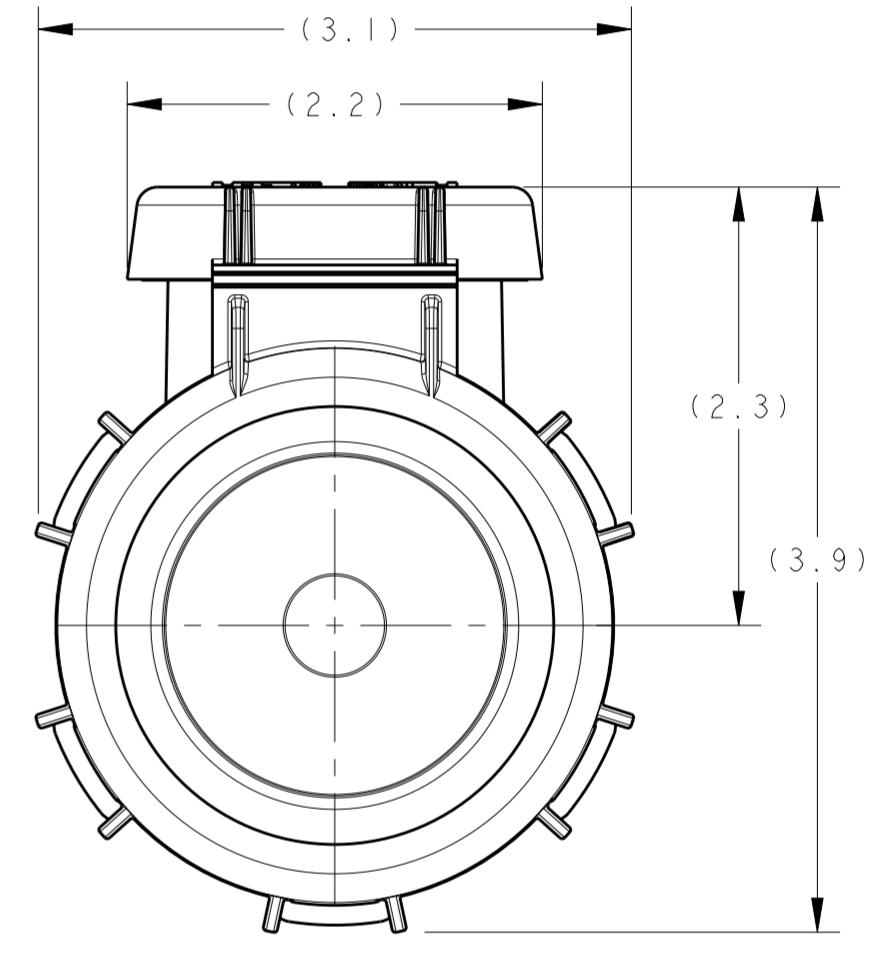
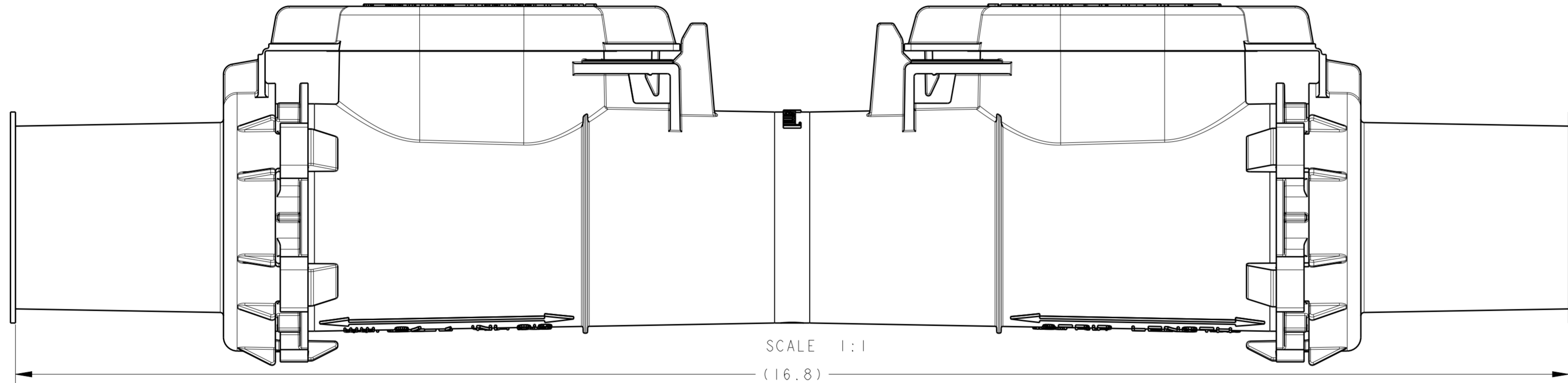
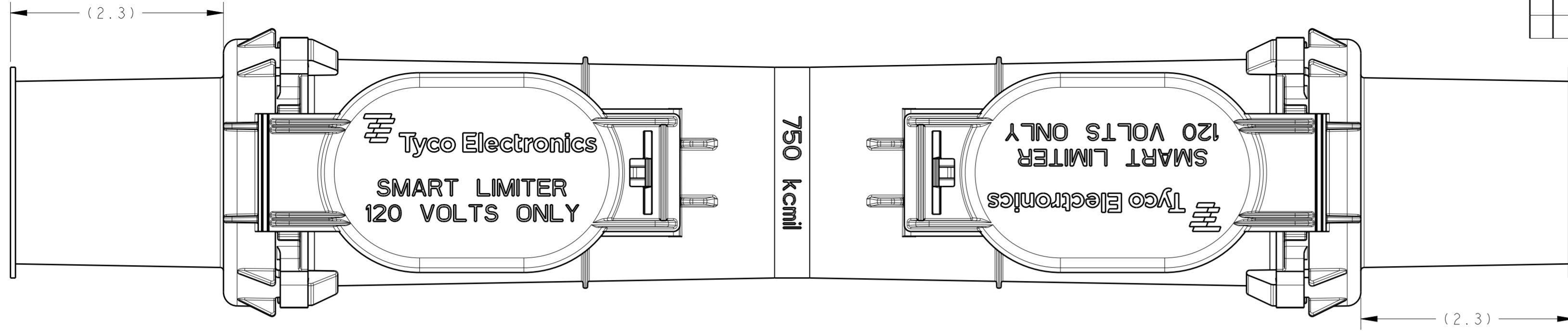
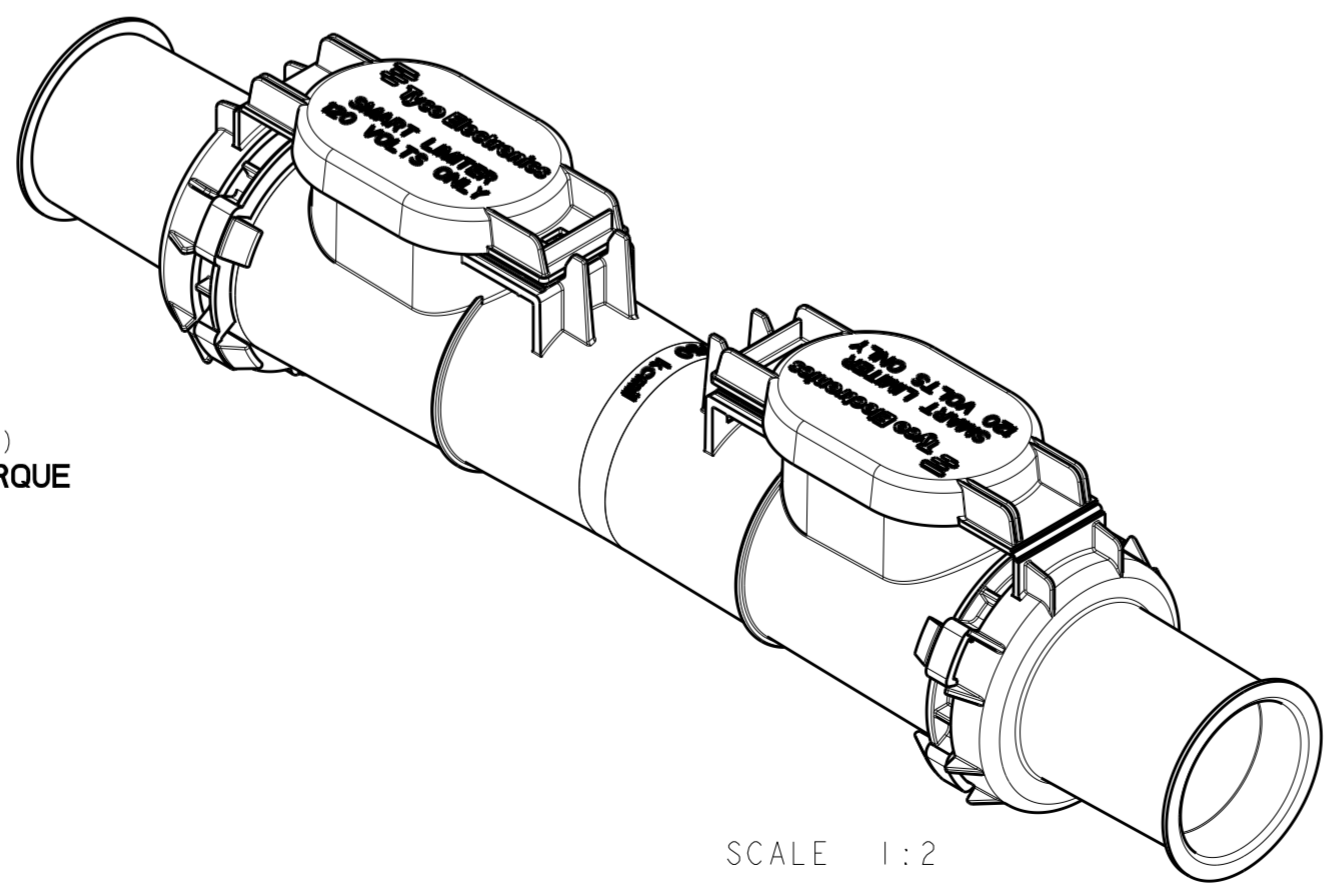

ITEM #	RPN	DESCRIPTION	WEIGHT (lbs)
1	CR5859-000	750 kcmil LIMITER	6.1

THIS DRAWING IS A CONTROLLED DOCUMENT.		DWN K. BLUE 3/23/2008	STE TE Connectivity	
DIMENSIONS: INCHES		CHK S. KAMEL		
TOLERANCES UNLESS OTHERWISE SPECIFIED:		APVD S. KAMEL	NAME SMART LIMITER ASSEMBLY 750MCM-01	
0 PLC	±N/A	PRODUCT SPEC	SIZE	CAGE CODE
1 PLC	±	APPLICATION SPEC	A2	-
2 PLC	±	WEIGHT	Customer Drawing	DRAWING NO G-SCD-N928
3 PLC	±		SCALE	RESTRICTED TO
4 PLC	±		1:2	-
ANGLES	±		SHEET	OF
FINISH	-		1	1
	-		REV	A