

THIS DRAWING IS UNPUBLISHED. RELEASED FOR PUBLICATION 20  
 © COPYRIGHT 20 BY - ALL RIGHTS RESERVED.

REVISIONS				
P	LTR	DESCRIPTION	DATE	APVD
A		RELEASE PER RTS# 867887	10/17/2013	SW SR

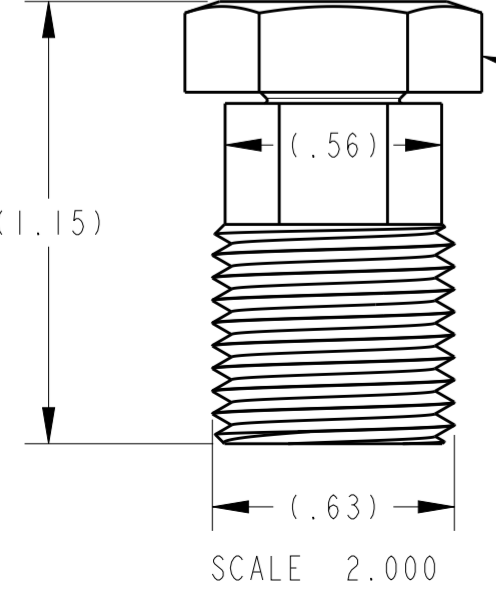
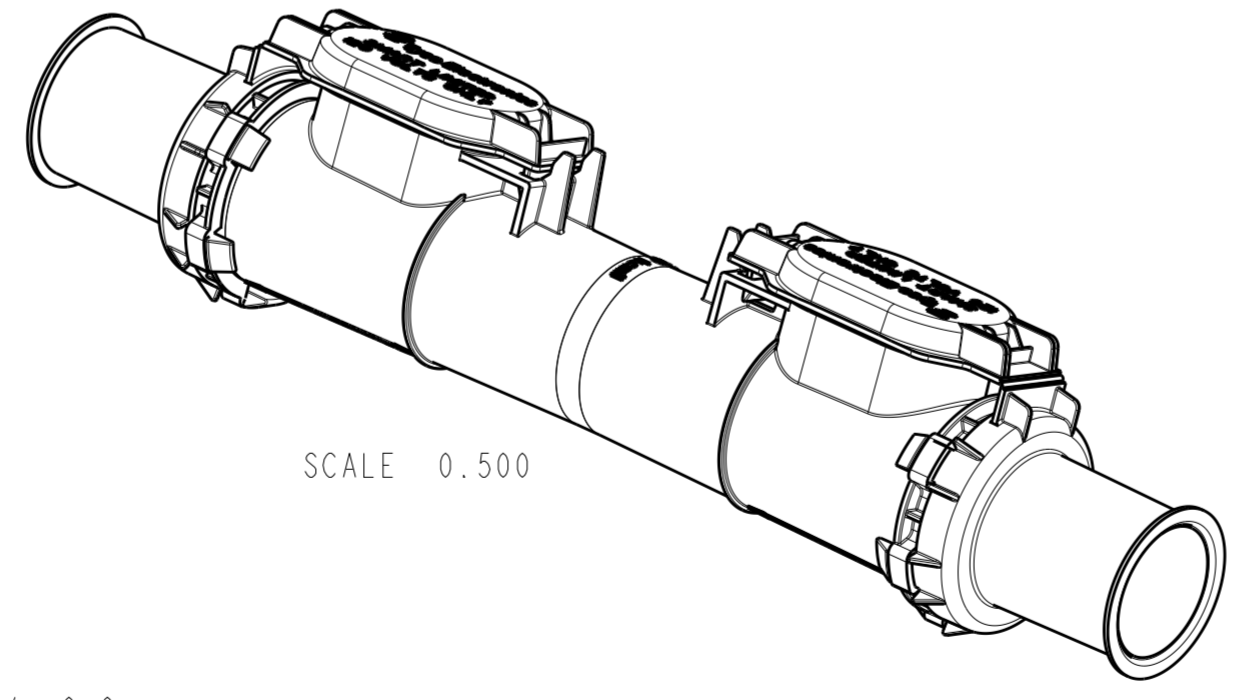
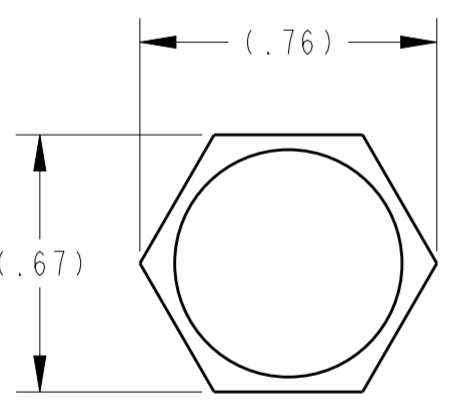
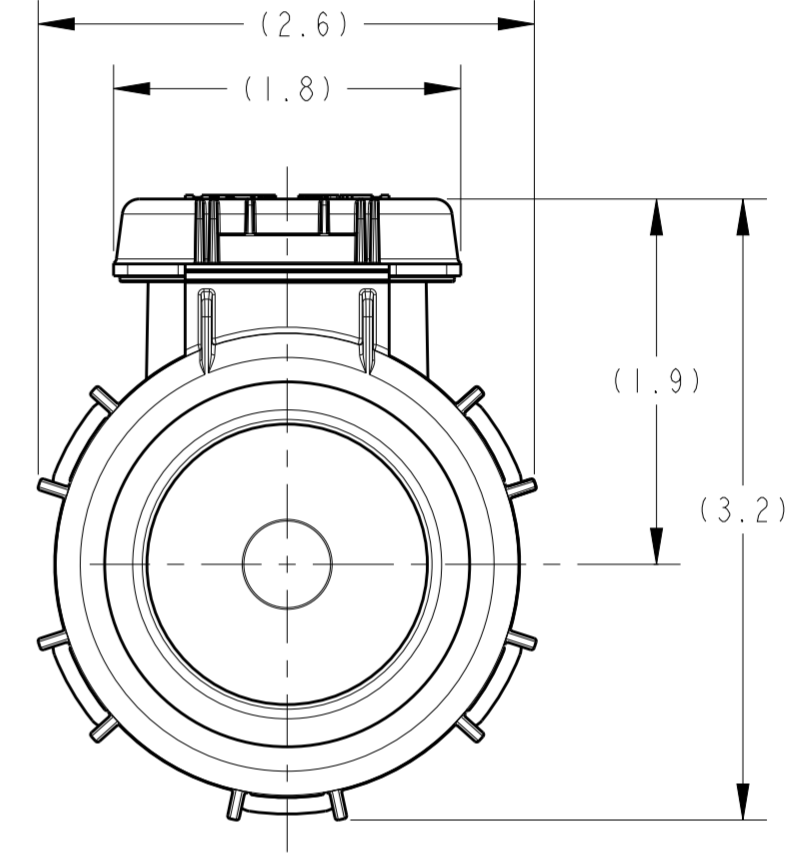
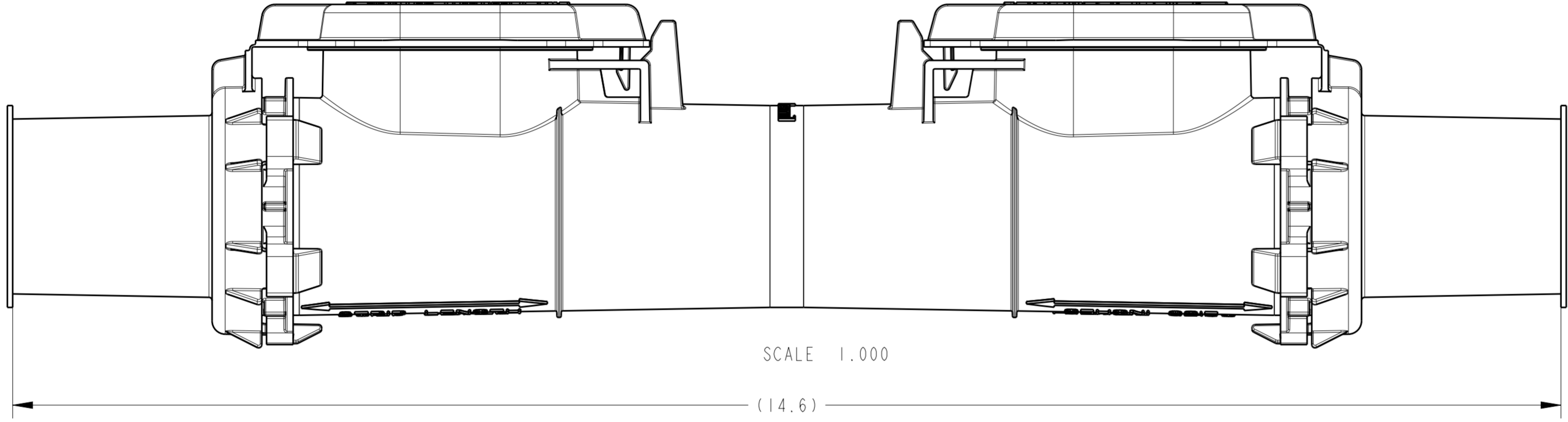
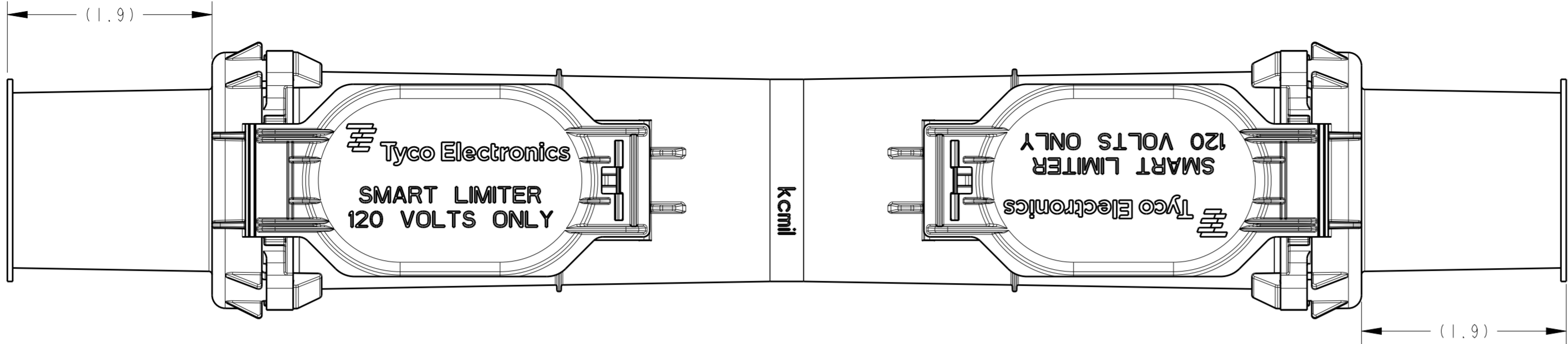

(Ref. RPN CL4974-000)  
**SHEAR BOLT - SHEAR TORQUE**  
 41 N-m +4 -0 or  
 30.24 ft-lb +2.9 ft-lb/- 0.0

ITEM #	RPN	DESCRIPTION	WEIGHT (lbs)
1	CR5853-000	470 kcmil LIMITER	4
1	CR5848-000	250 kcmil LIMITER	4.1
1	CR5856-000	350 kcmil LIMITER	4
1	CL4587-000	500 kcmil LIMITER	4

THIS DRAWING IS A CONTROLLED DOCUMENT.

DIMENSIONS: INCHES	TOLERANCES UNLESS OTHERWISE SPECIFIED: 0 PLC ±N/A 1 PLC ± 2 PLC ± 3 PLC ± 4 PLC ± ANGLES ± FINISH	DWN: K. BLUE 1/3/2007 CHK: S. KAMEL APVD: S. KAMEL PRODUCT SPEC APPLICATION SPEC WEIGHT	TE Connectivity NAME: SMART LIMITER ASSEMBLY 500-470 SIZE: A2 CAGE CODE: - DRAWING NO: C-SCD-N927 RESTRICTED TO:	
MATERIAL: -	-	CUSTOMER DRAWING	SCALE: 1.000	SHEET: 1 OF 1 REV: A