

ITEM	QTY	DESCRIPTION
1	1	Threaded Pin M16
2	1	Assembly Main Body
3	1	HEL-75150-800A
4	1	Cable
5	1	Mastic
6	1	Stress Cone Adapter RSTI-SCA
7	1	Spring Wedge
8	1	Hexagon Nut ISO 4035 M16 A2
9	1	Back Plug 24kV
10	1	Covering Endcap
11	1	Clamping screw M6
12	1	Ground Lead
13	1	Washer DIN 9021 - 6.4 A2
14	1	Hexagon Nut ISO 4035 - M6 A2
15	1	Washer DIN 125 - 8.4 A2

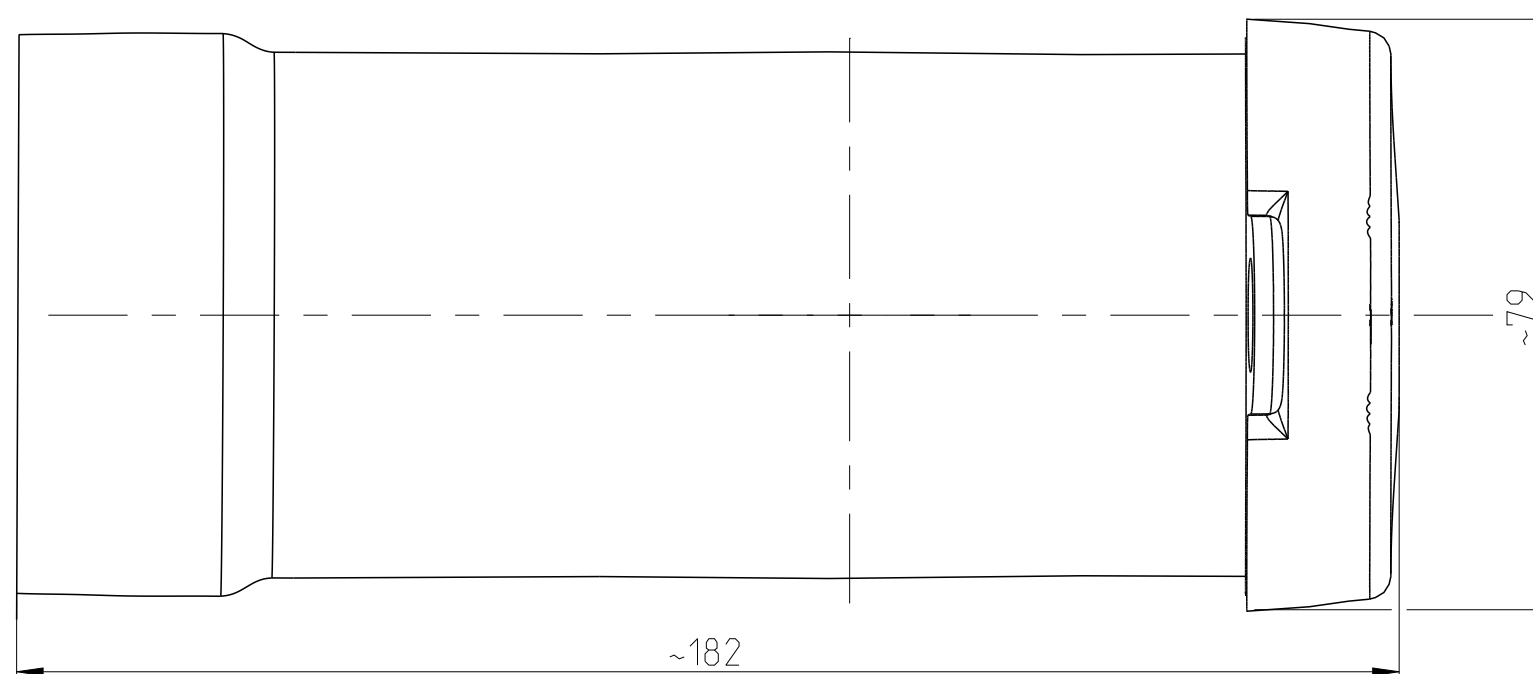

REVISIONS				
P	LTM	DESCRIPTION	DATE	APVD
A		PRODUCTION RELEASE	21SEP2022	AL TF

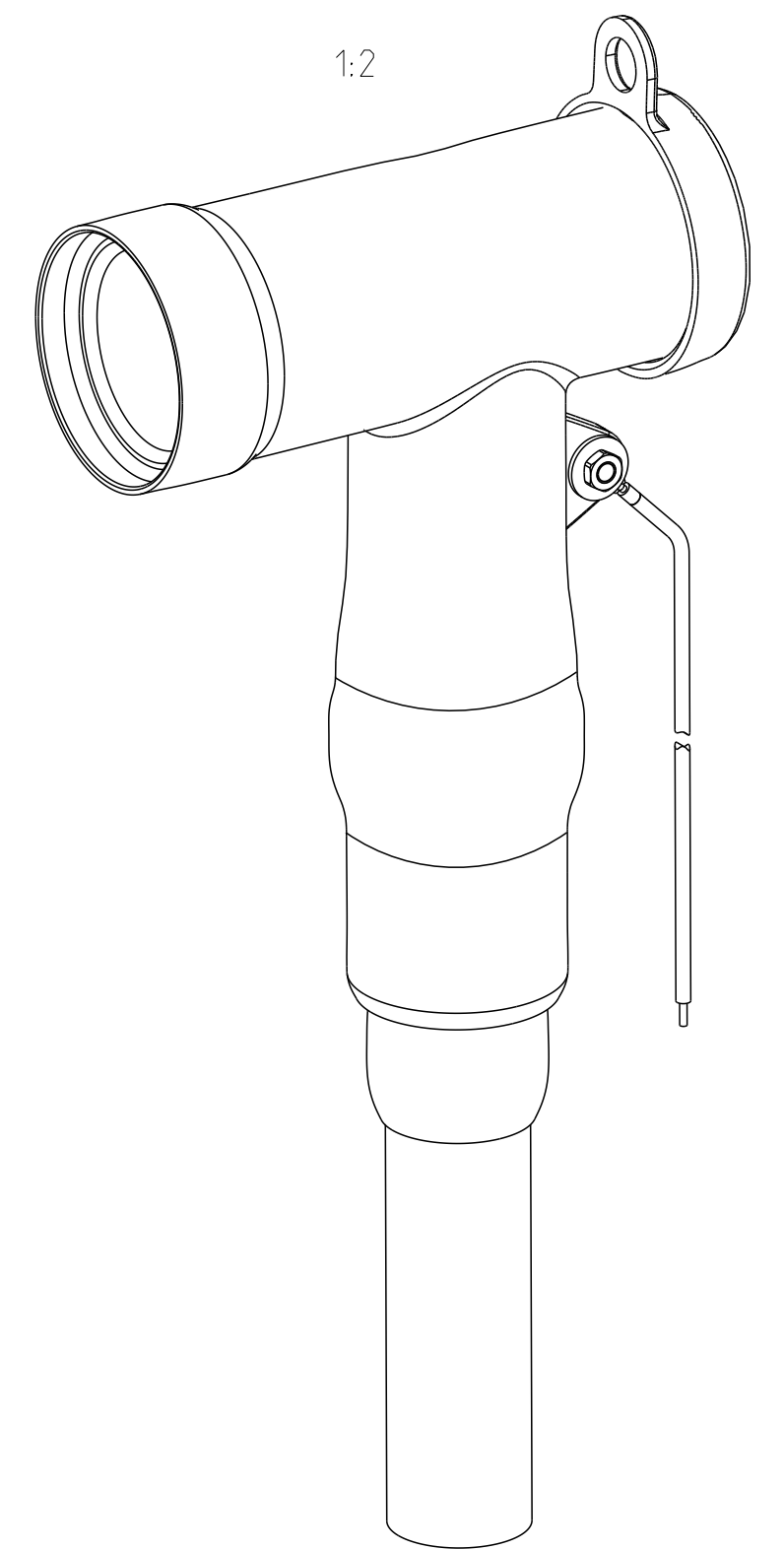
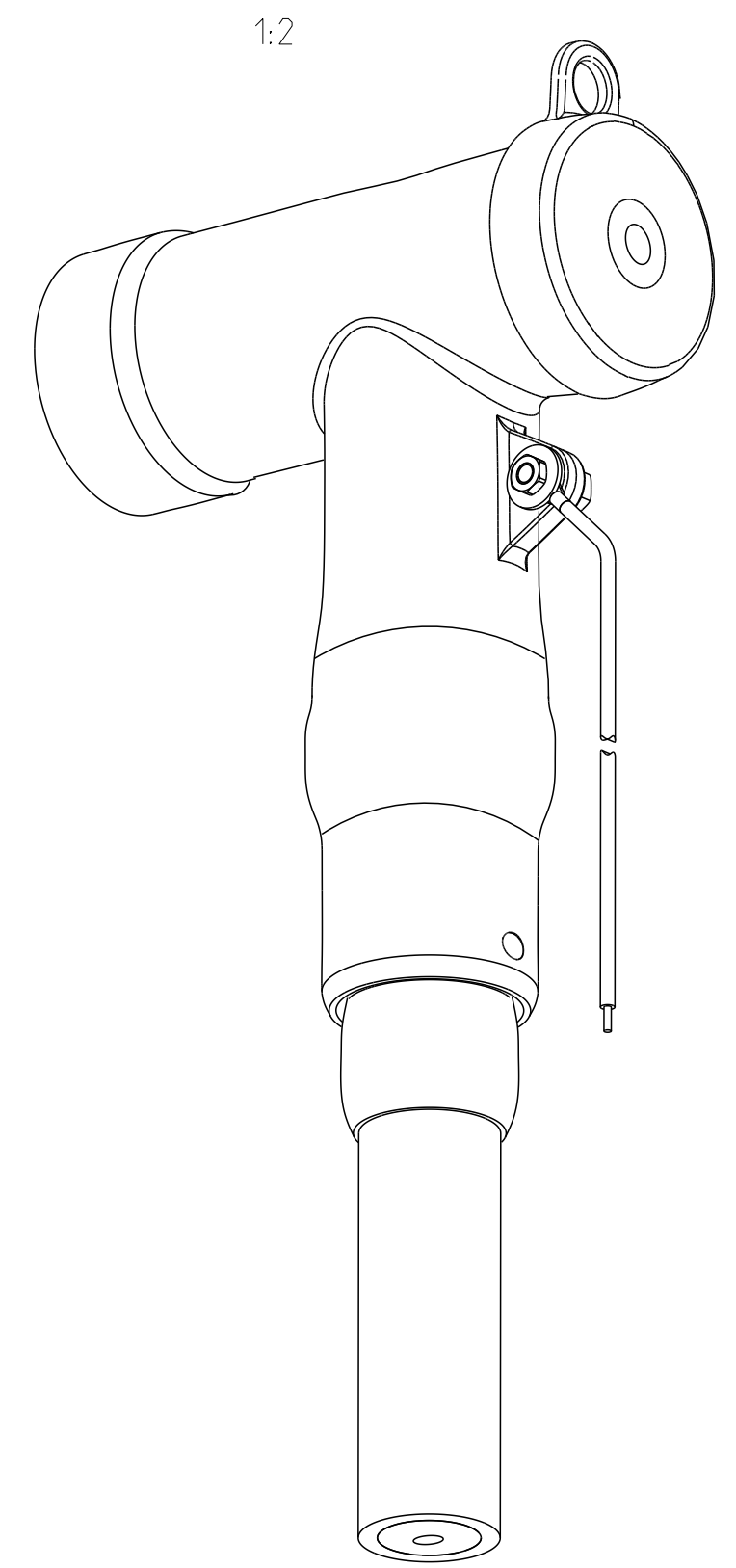

THIS DRAWING IS A CONTROLLED DOCUMENT.		DWN: LOGANATHAN A CHK: T.FRIEDRICH APVD: J.VALENCIA	19SEP2022 19SEP2022 19SEP2022	TE Connectivity
DIMENSIONS: mm	TOLERANCES UNLESS OTHERWISE SPECIFIED: 0 PLC ± 1 PLC ± 2 PLC ± 3 PLC ± 4 PLC ± ANGLES ±	NAME: RSTI-5826 PRODUCT SPEC: APPLICATION SPEC: SIZE: A CAGE CODE: 00779 DRAWING NO: RSTI-5826	RESTRICTED TO: CUSTOMER DRAWING	SCALE: 1:1 SHEET: 1 OF 1 REV: A