



## CODE 52 - BRAID TAIL BACKSHELL

**208M012-19B06**

BASE PART NUMBER \_\_\_\_\_  
 SHELL SIZE \_\_\_\_\_  
 MATERIAL NUMBER \_\_\_\_\_  
     19 - ALUMINIUM ALLOY  
     62 - STAINLESS STEEL  
 FINISH DESIGNATION \_\_\_\_\_  
     SEE SS0076  
 ENTRY SIZE \_\_\_\_\_

### NOTES:

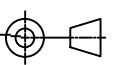
1. THIS PRODUCT IS DESIGNED TO TERMINATE A BRAIDED CABLE AND A HEAT SHRINKABLE LIPPED BOOT TO A CONNECTOR.
2. TEMPERATURE RANGE FOR ALUMINIUM ALLOY -65°C TO +150°C.
3. BACKSHELL MATES TO MIL-C-26500 STAINLESS STEEL SHELL (CLASS E ONLY) AND PYLE ZZ\*-R SERIES CONNECTORS.
4. FOR ADDITIONAL DIMENSIONS, ORDERING INFORMATION AND MODIFICATIONS, SEE CH00-0250-004.
5. BACKSHELL TO BE PERMANENTLY MARKED/BAGGED AND LABELLED WITH CODE IDENTIFICATION NUMBER AND PART NUMBER. (e.g. 06090-208M012-19B06).
6. FOR LARGER ENTRY SIZES A 2 PIECE ADAPTOR (TYPE II) IS SUPPLIED.
7. BRAID TERMINATION RING MAY BE SUPPLIED AS TINEL-LOCK SHAPE MEMORY RING AT MANUFACTURER'S OPTION.
8. ANTI-ROTATIONAL SET SCREW. 3 THREADED HOLES 120° ± 5°. SINGLE MATING SET SCREW SUPPLIED. NOT REQUIRED FOR TYPE II ADAPTORS.

DRAWN		DATE		 3RD ANGLE PROJECTION NOT TO SCALE	PART NUMBER:			<b>208M0XX SERIES</b>			 <b>Polamco</b> 
K.K-W		20/04/2018			TITLE:						
DESIGN APPROVAL		DATE		UNLESS OTHERWISE SPECIFIED ALL DIMENSIONS IN MILLIMETRES GENERAL TOL LINEAR +/-0,25MM ANGULAR +/- 1°			<b>ASSY USED ON: MIL-DTL-26500 STAINLESS STEEL SHELL (CLASS E ONLY), PYLE ZZ*-R SERIES CONNECTORS.</b>				
K.SHEPPARD		20/04/2018								<b>MATERIAL</b> SEE PART NUMBER BREAKDOWN	
DOC TYPE	Customer Drawing			<b>FINISH</b> SEE PART NUMBER BREAKDOWN			POLAMCO LTD, WESTON LOCK, LOWER BRISTOL ROAD BATH BA2 1EP		SHT	DRAWING NO:	
ISSUE	REV.	DCR					1		P42595		
NCAGE CODE U5792		WEIGHT N/A									

IF MAX ENTRY IS EXCEEDED ADAPTOR  
WILL BE SUPPLIED AS TYPE 2

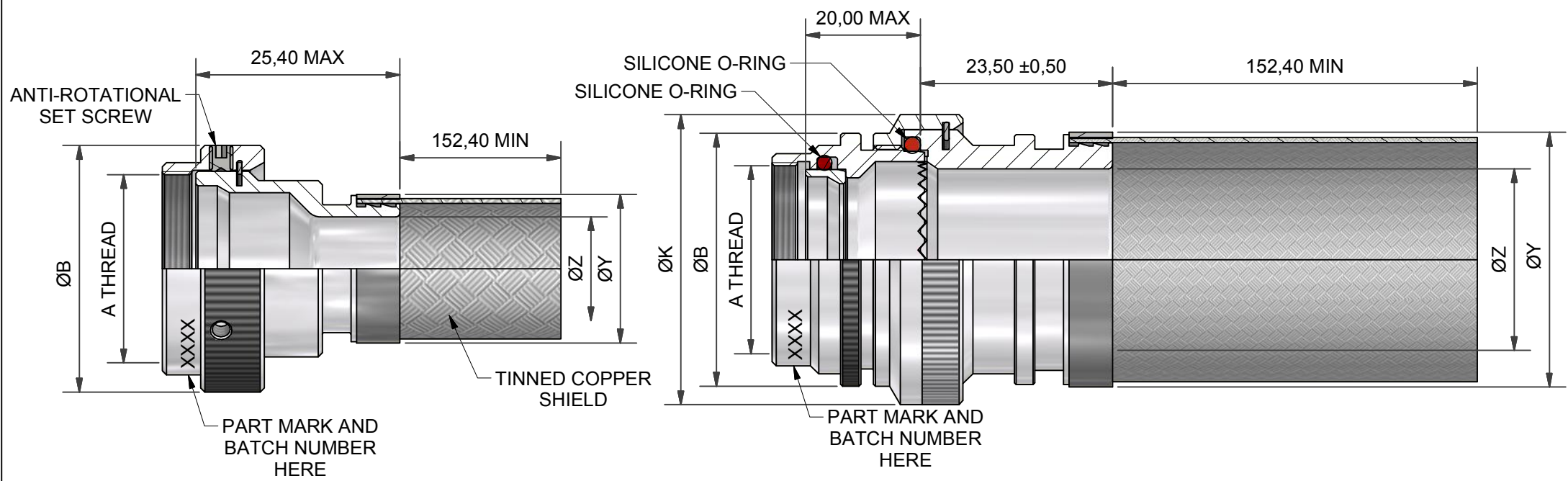

TABLE 1

SHELL SIZE	MAX ENTRY	A THREAD CLASS 2B	ØB MAX
12	09	.733-36 UNS	27,9
14	10	.803-36 UNS	29,5
16	12	.930-36 UNS	32,8

TABLE 2

ENTRY SIZE	ØK MAX	ØZ REF	ØY REF
03	NA	4,77	13,1
04	NA	6,35	13,1
05	NA	7,92	13,1
06	NA	9,52	17,9
07	NA	11,12	17,9
08	NA	12,70	17,9
09	NA	14,27	17,9
10	29,0	15,87	24,2
11	29,0	17,47	24,2
12	32,5	19,05	24,2
13	35,5	20,62	24,2
14	35,5	22,23	30,6
15	37,0	23,82	30,6
16	37,0	25,40	30,6
17	40,0	26,98	33,2
18	40,0	28,60	33,2
20	43,5	31,80	42,0
21	48,5	33,34	42,0
22	48,5	35,00	42,0
24	52,1	38,10	42,0
28	58,5	44,45	49,0

DRAWN		DATE		 3RD ANGLE PROJECTION NOT TO SCALE	PART NUMBER:			 <b>208MOXX SERIES</b>								
K.K-W		20/04/2018			TITLE:						<b>BRAID TAIL BACKSHELL</b>					
DESIGN APPROVAL		DATE		UNLESS OTHERWISE SPECIFIED ALL DIMENSIONS IN MILLIMETRES GENERAL TOL LINEAR +/-0,25MM ANGULAR +/- 1°				ASSY USED ON: MIL-DTL-26500 STAINLESS STEEL SHELL (CLASS E ONLY), PYLE ZZ*-R SERIES CONNECTORS.						 POLAMCO LTD, WESTON LOCK, LOWER BRISTOL ROAD BATH BA2 1EP		
K.SHEPPARD		20/04/2018			MATERIAL SEE PART NUMBER BREAKDOWN  FINISH SEE PART NUMBER BREAKDOWN						THIS DRAWING IS COPYRIGHT AND THE PROPERTY OF POLAMCO LTD IT MUST NOT BE COPIED, USED FOR MANUFACTURE OR OTHERWISE DISCLOSED WITHOUT PRIOR WRITTEN CONSENT OF THE COMPANY.					
DOC TYPE	Customer Drawing															
ISSUE	REV.	DCR		WEIGHT			2									
J	---	---		N/A			P42595									
NCAGE CODE U5792		WEIGHT N/A		POLAMCO LTD, WESTON LOCK, LOWER BRISTOL ROAD, BATH BA2 1EP			DRAWING NO: P42595									