

REVISIONS				
REV	DESCRIPTION	DATE	CHANGED BY	APPROVED BY

DO NOT ASSEMBLE PRIOR TO USE

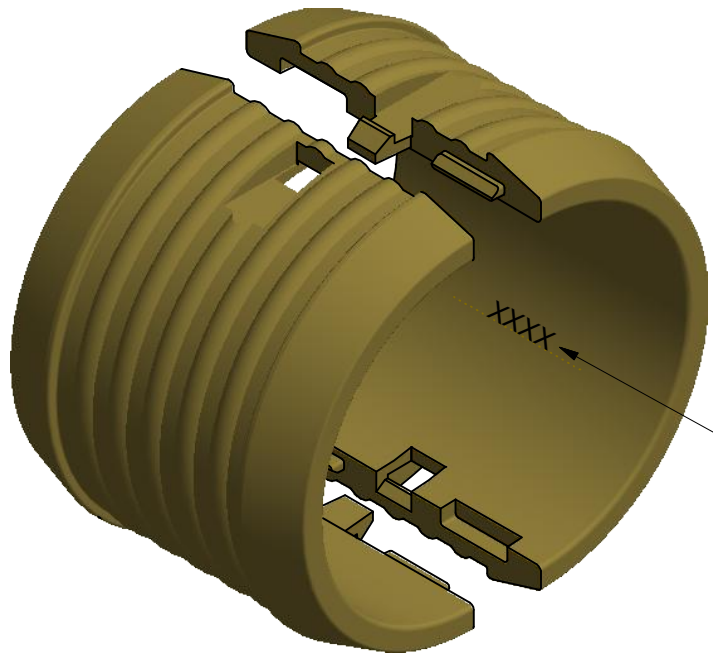

PART MARK, CAGE CODE AND DATE HERE

DASH NUMBER	ØA +/- .0100" (+/- 0.25)	ØB MAX
04	.250" (6.35)	.390" (9.90)
06	.375" (9.52)	.515" (13.10)
08	.500" (12.70)	.640" (16.30)
10	.625" (15.88)	.770" (19.60)
12	.750" (19.05)	.903" (22.90)
14	.875" (22.22)	1.043" (26.50)
16	1.000" (25.40)	1.173" (29.80)
18	1.125" (28.58)	1.310" (33.30)

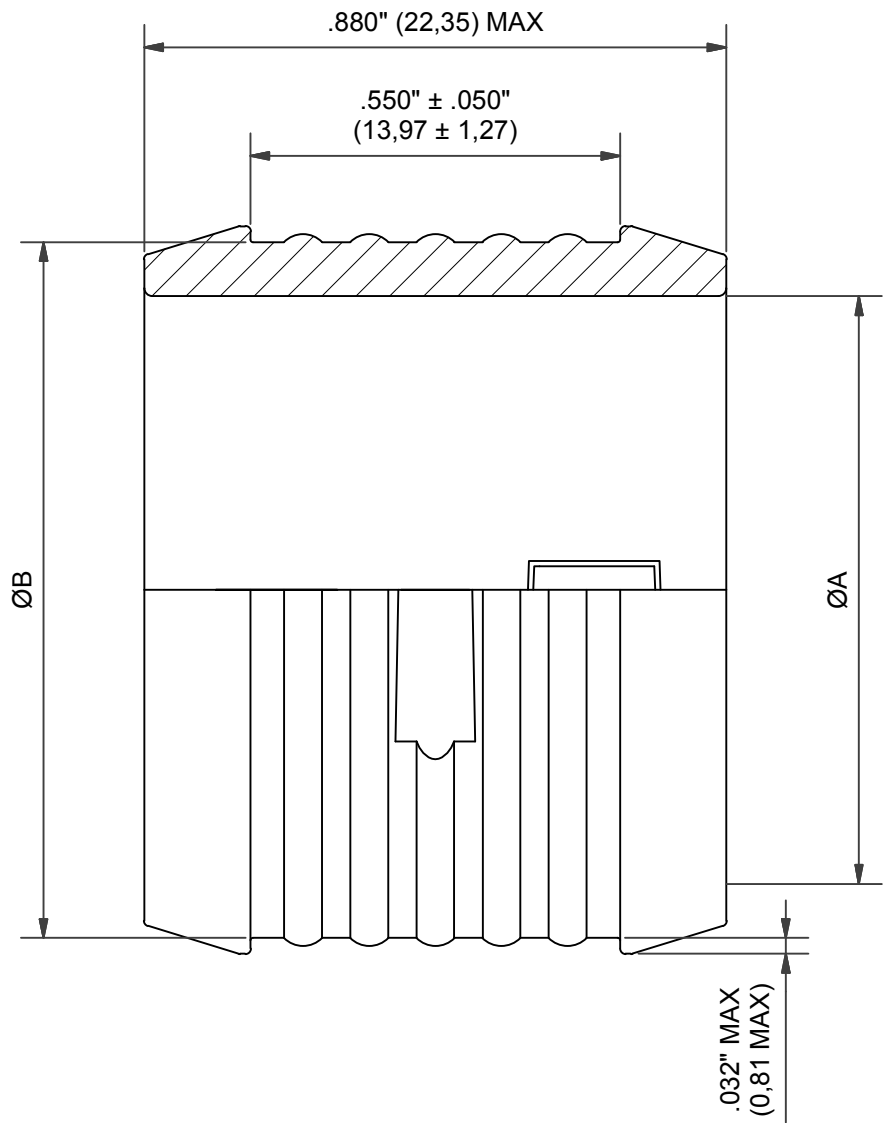

RELEASED FOR PUBLICATION - DD/MM/YYYY

ALL RIGHTS RESERVED

THIS DRAWING IS UNPUBLISHED

© COPYRIGHT - TE CONNECTIVITY

DIMENSIONS INCHES	DWN: N.HAWKINS	18/04/2018	MATERIAL: ULTEM - 2300 NATURAL	FINISH: N/A
	TE TE CONNECTIVITY			
TOLERANCES UNLESS OTHERWISE SPECIFIED:	CHK:		PART NUMBER: BND-SR-*	
	APRD: K.SHEPPARD	22/04/2018	NAME: SHIELD TERMINATION SPLIT SUPPORT RING, COMPOSITE	
GENERAL TOL LINEAR +/- 0.01" ANGULAR +/- 1°	PRODUCT SPEC: AS85049-93		RESTRICTED TO:	
	APPLICATION SPEC: -		SIZE: A4	CAGE CODE: 06090
	WEIGHT: N/A		DRAWING NO: P40352	SCALE: 2.5 : 1
	Customer Drawing			SHEET: 1 OF 2
				REV: BA

TE PROPRIETARY PART NUMBER:

BND-SR-10

SERIES _____
DASH NUMBER _____

QPL PART NUMBER:
(QUALIFICATION PENDING)

R85049/93-10

SERIES _____
DASH NUMBER _____

NOTES: -

- DESCRIPTION: TWO PIECES OF SPLIT FERRULES IN ACCORDANCE WITH AS85049/93
- MILITARY PART NUMBER: THIS PRODUCT IS IN COMPLIANCE WITH THE REQUIRMENTS OF AS85049 AND AS85049/93 UNDER THE PART NUMBERS M85049/93-XX. "XX" ARE DASH NUMBERS LISTED IN AS85049/93.
- PARTS MAY BE ORDERED BY THE MILITARY DESIGNATION OR MANUFACTURER'S DESIGNATION LISTED IN THE APPLICABLE QUALIFIED PARTS LIST PUBLISHED BY THE QUALIFYING ACTIVITY - SEE AS85049.

MILITARY DESIGNATION: M85049/93-XX
TE'S DESIGNATION: R85049/93-XX

- MARKING: PARTS ARE MARKED WITH MILITARY DESIGNATION ON ONE OF THE TWO HALVES ONLY.

EXAMPLE: M85049/93-04 FOR DASH 04 PART

- FOR PERFORMANCE REQUIREMENTS, SEE AS85049 AND AS85049/93.
- MATERIAL: POLYETHERIMIDE, NATURAL
- INTENDED USE: USED TO PROVIDE SUPPORT WHEN TWO DISCRETE CABLE SHIELDS ARE ELECTRICALLY CONNECTED USING AS85049/128 CORROSION RESISTING BANDS.

RELEASED FOR PUBLICATION - DD/MM/YYYY

ALL RIGHTS RESERVED

THIS DRAWING IS UNPUBLISHED

© COPYRIGHT - TE CONNECTIVITY

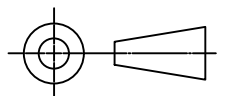
DIMENSIONS INCHES	DWN: N.HAWKINS	18/04/2018	MATERIAL: ULTEM - 2300	NATURAL	FINISH: N/A
	TE TE CONNECTIVITY				
TOLERANCES UNLESS OTHERWISE SPECIFIED:	CHK:		PART NUMBER: BND-SR-*		
	APRD: K.SHEPPARD	22/04/2018	NAME: SHIELD TERMINATION SPLIT SUPPORT RING, COMPOSITE		
GENERAL TOL LINEAR +/-0.01" ANGULAR +/- 1°	PRODUCT SPEC:				
	AS85049-93				
	APPLICATION SPEC:				
	-				
	WEIGHT: N/A		SIZE: A4	CAGE CODE: 06090	DRAWING NO: © P40352
	Customer Drawing			RESTRICTED TO:	
			SCALE:	SHEET: 2 OF 2	REV: BA