

**HARDWARE OPTION
FSK / RH - HEX SOCKET
RETRACTABLE SCREW**

STYLE F

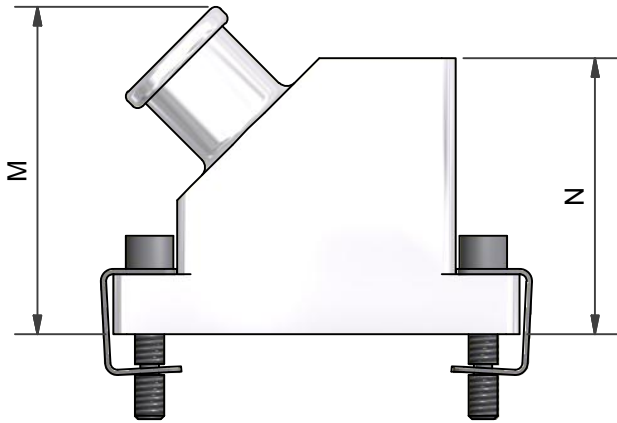

STYLE U

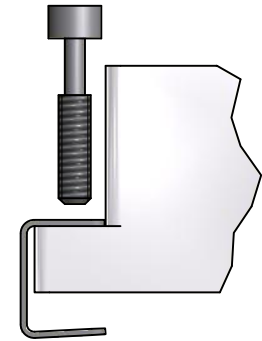
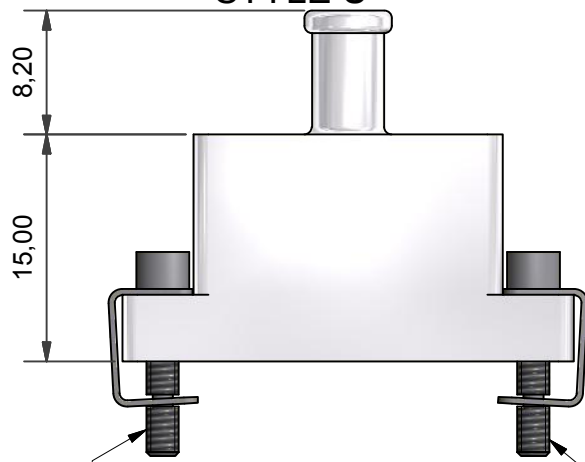

**HARDWARE OPTION
HE - HEX SOCKET SCREW
WITH E-CLIP**

SK - HEX SOCKET HEAD SCREW

G THREAD

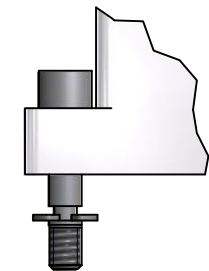
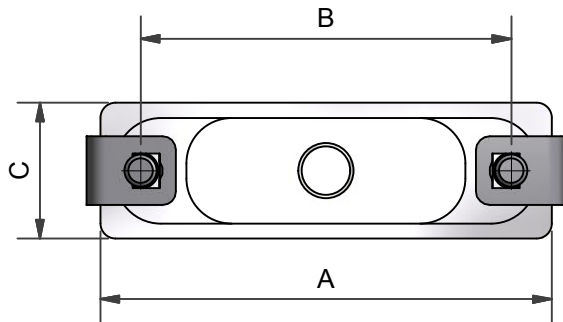

**HARDWARE OPTION
SL - SLOTTED HEAD
SCREW**

MBMM-U-25-02-1-C-HE

- SERIES
- ENTRY POSITION (U - TOP ENTRY)
- SHELL SIZE
- ENTRY SIZE
- MATERIAL
- FINISH
- OPTIONAL HARDWARE CONFIGURATION
(FSK / RH - RECTRACTABLE HEX SOCKET HEAD)
(HE - HEX SOCKET HEAD AND E-CLIP)
(SL - SLOTTED HEAD JACKSCREW)
(SK - SOCKET HEAD JACKSCREW)

SHELL SIZE	A	B	C	G THREAD	M MAX	N	MAX ENTRY
09	19,68	14,35	9,0	2-56UNC	25,4	16,5	04
15	23,50	18,16	9,0	2-56UNC	26,2	17,8	05
21	27,30	21,97	9,0	2-56UNC	26,7	18,7	06
25	29,84	24,51	9,0	2-56UNC	27,7	20,3	07
31	33,66	28,32	9,0	2-56UNC	28,7	21,8	07
37	37,46	32,13	9,0	2-56UNC	31,2	23,5	08
51	36,20	30,86	10,0	2-56UNC	31,8	24,8	08
100	54,86	45,72	11,0	4-40UNC	33,5	26,7	11

ENTRY SIZE	D	E	F
01	1,58	-	-
02	3,18	-	-
03	4,77	-	-
04	6,35	-	-
05	-	10,8	5,8
06	-	15,2	5,8
07	-	17,9	6,5
08	-	22,8	6,8
11	-	35,8	8,4

CODE	MATERIAL / PLATING
1-C	ALUMINIUM / ELECTROLESS NICKEL
1-B	ALUMINIUM / CADMIUM OLIVE DRAB OVER ELECTROLESS NICKEL
1-ZB	ALUMINIUM / ZINC COBALT OLIVE DRAB OVER ELECTROLESS NICKEL
4-J	STAINLESS STEEL / PASSIVATE
2-Z	NICKEL ALUMINIUM BRONZE / SHOT BLAST

LIST NOT EXHAUSTIVE, FOR COMPREHENSIVE LIST AND SPECS, SEE WEBSITE

DRAWN	DIW	DATE 24/02/2016	 3RD ANGLE PROJECTION NOT TO SCALE	PART NUMBER:	<h2 style="margin: 0;">MBMM SERIES</h2> <h3 style="margin: 0;">MICRO MIN MICRO BAND BACKSHELL</h3>	 Polamco
SALES APPR	MXF	24/02/2016		TITLE:		
DESIGN APPR				ASSY USED ON: MIL-DTL-83513		
PROD APPR				THIS DRAWING IS COPYRIGHT AND THE PROPERTY OF POLAMCO LTD IT MUST NOT BE COPIED, USED FOR MANUFACTURE OR OTHERWISE DISCLOSED WITHOUT PRIOR WRITTEN CONSENT OF THE COMPANY.		
QUAL APPR				POLAMCO LTD, WESTON LOCK, LOWER BRISTOL ROAD BATH BA2 1EP		
ISSUE	REV.	DCR		SHT	DRAWING NO:	
2		6332		1	P27252	
NCAGE CODE U5792		WEIGHT				