

NOTES:

1. ASSEMBLY IDENTIFICATION PER MIL-STD-130
2. MATERIALS:
 ADAPTER: QQ-A-225/3, T3 OR QQ-A-225/6, T4.
 DRIVE BAND: QQ-A-225/8, T0.
 SHIELD: TINNED COPPER 36 GAUGE PER QQ-B-575
3. FINISH:
 ADAPTER: ELECTRO-TIN PER MIL-T-10727, TYPE I, .0003 INCH MINIMUM THICKNESS.
 DRIVE BAND: CHEM FILM PER MIL-C-5541.
4. ELECTROFORMED SHIELD ADAPTER/DRIVE BAND JOINT SHALL BE CAPABLE OF WITHSTANDING 200 POUND TENSILE PULL.
5. THREADED ADAPTER SHALL CONTAIN THE LSS PART NUMBER.

REVISIONS		
LTR	DESCRIPTION	DATE
A	INITIAL RELEASE PER DCR NO. R060459	09/27/06

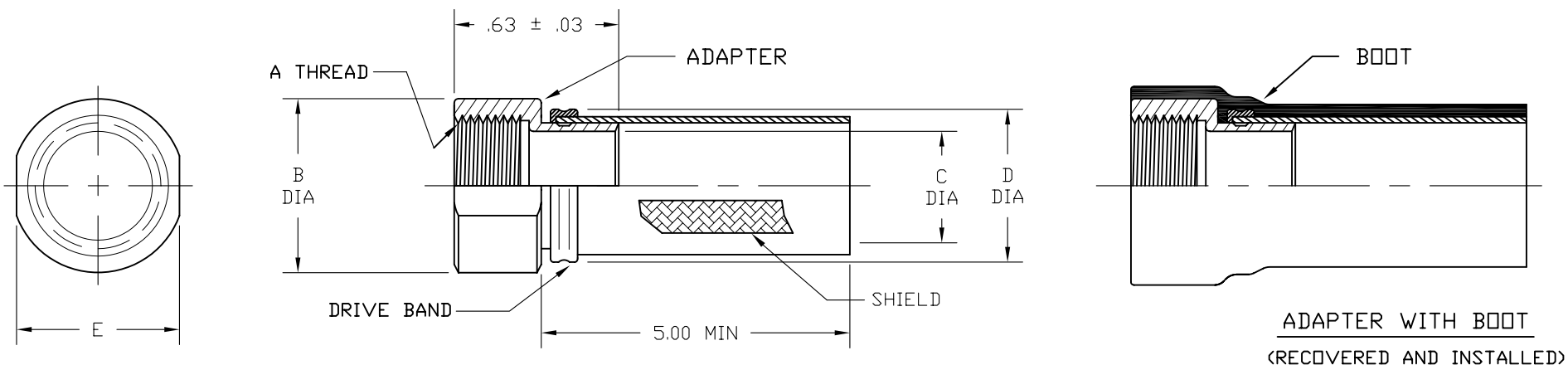

RAYCHEM ADAPTER							RAYCHEM BOOT
PART DESCRIPTION/RPN	SHELL SIZE	A THREAD, R.H. CLASS 2B	B ±.02 [.5]	C ±.01 [.3]	D REF.	E ±.02 [.5]	PART DESCRIPTION/RPN
1-LSS-26-8A 095877-000	08	.438 - 28 UNEF	.56 [14.2]	.32 [8.1]	.54 [13.7]	.52 [13.2]	202D211-4-26 808827-000

If this document is printed it becomes uncontrolled.
Check for the latest revision.

SPECIFICATION CONTROL DRAWING

© 2006 Tyco Electronics Corporation. All rights reserved.		Tyco Electronics Corporation 300 Constitution Drive Menlo Park, CA. USA 94025				
UNLESS OTHERWISE SPECIFIED DIMENSIONS ARE INCHES. METRIC DIMENSIONS ARE IN BRACKETS. DECIMAL TOLERANCES .XXX ± 0.005 [0.13 mm] .XX ± 0.01 [0.25 mm] .X ± 0.1 [0.50 mm] ANGLE TOLERANCE .X ± 1 DEG.	DRAWN U. NGUYEN	DATE 09/27/06	TITLE			
	CAD FILE R060459		EMF SHIELD ADAPTER WITH THERMOFIT BOOT FOR MIL-C-26482 CONNECTORS			
	RPN 899170S004		SIZE A	CODE IDENT NO. 06090	DWG. NO. LSS-26-8A	
	THIRD ANGLE PROJECTION		DO NOT SCALE THIS DRAWING		SHEET 1 OF 1	